

1968-1972 OPEL KADETT



The Kadett: Opel's economy workhorse of the 1960's. The first Kadett in the USA was the A model from 1964-1967, first with the 1.0L followed in '66 by the 1.1L. The Kadett B followed in mid-year 1967, commonly referred to as the '67 1/2. In 1968 the Kadett's engine options were drastically increased, the base engine was still the 1.1L followed by the higher output dual carburetor 1.1SR engine, the 1.5L CIH and the 1.9L Super Kadett engine. The B model Kadett continued until 1972.

Kadetts were sold through GM's Buick dealership network with the advertising nickname the 'Mini-Brute'. Super-economy was also a high selling point with 30+ mpg performance from the 1.1L engine coupled to the 4 speed transmission and high axle ratio. This combination made for spirited performance all for under \$2000 dollars.

In 1967 1/2, when the Kadett B was introduced as a 1968 model, the redesigned body featured the all new CIH (Cam-In-Head) 1.5L and 1.9L engines. The Kadett Rallye was also introduced with its stylish twin hood black outs and side stripes. A simulated wood grain steering wheel was introduced along with front fog lamps and a 3.67:1 rear axle final drive. The later could also be special ordered with a limited slip differential. In 1969 and 70 the Kadett Rallye came exclusively with the 1.9L engine and optional chrome '15 hole' sport wheels. The Kadett Rallye option was dropped in 1971 with the introduction of the Manta and Manta Rallye, with sales of the Kadett terminating in 1972.

Tens of thousands of Opel Kadetts were sold in the USA from 1968 thru 1972 with the 2-door Fast-Back being extremely popular with college students, and the Station Wagon selling big as an affordable rugged family car. If you are lucky enough to own one of these Kadetts today, rest assured you have both a unique and classic Opel.

Kadett - B, Model Identification 1968-1972

Opel Kadett Model numbers 'as sold' for the US market.

Vehicle Identification Number (VIN): The first two (2) digits of the VIN indicates the model designation.

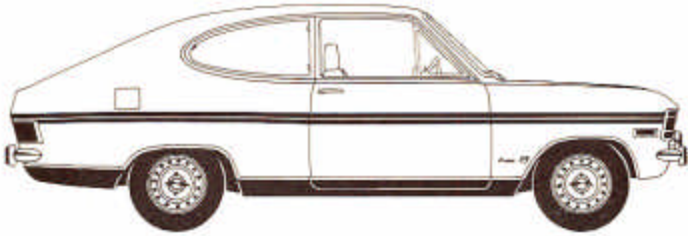

Model 92 Kadett Rallye

Kadett Rallye 1968-1970

"This snappy little number from Opel looks and acts like the true performer it is." Quote: Opel 1970 selling manual.

Colors: Spring Green (HH), Chrome Yellow (YY) and Rallye Orange (BB) came with black interior.

Colors: Aztec Gold (GG) and Copper Bronze (WW) came with buckskin interior.

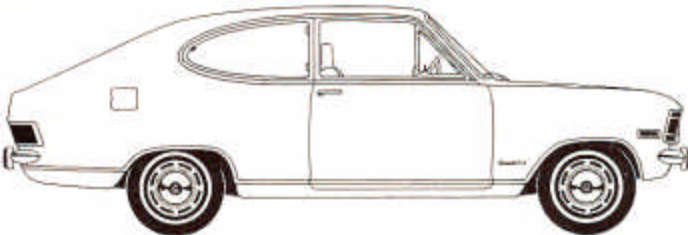

Model 95 Kadett Deluxe Sport Coupe'

Kadett Sport Coupe 1968-1970

"Here's an Opel that looks great regardless of where it goes." Quote: Opel 1970 selling manual.

Colors: Flame Red (RR), Spring Green (HH) and Chrome Yellow (YY) came with black interior.

Colors: Strato Blue (DD), Aztec Gold (GG) and Copper Bronze (WW) came with buckskin interior.

Colors: Brilliant White (CC) with red interior.

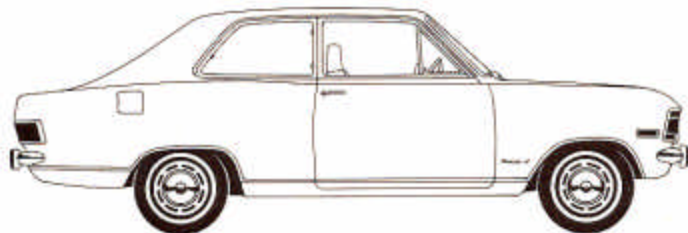

Model 91 Kadett Deluxe Sport Sedan

Kadett Sport Sedan 1968-1970

"Put text book economics into practice with this budget minded 'Mini-Brute.'" Opel 1970 selling manual.

Note: Same Exterior/Interior colors listed under the Kadett Sport Coupe.

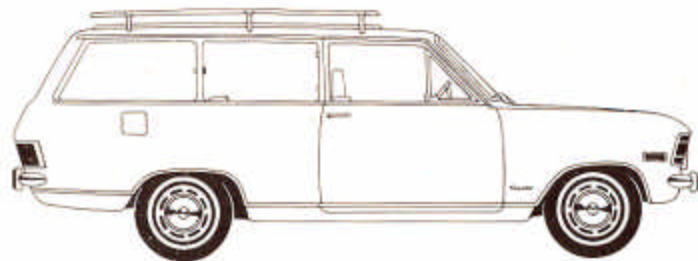

Model 39 Kadett Station Wagon

Kadett Station Wagon 1968-1972

"There's a lot to brag about when it comes to this gem of a 'Mini-Brute. Sips regular fuel. Over 55 cubic feet of haul-anything cargo space." Opel 1970 selling manual.

Note: Same Exterior/Interior colors listed under the Kadett Sport Coupe.

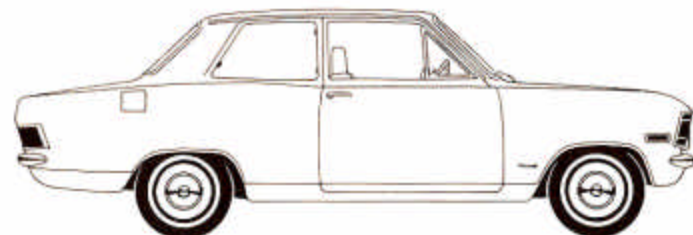

Model 31 Kadett Sedan 2 dr.

Kadett 2 Door Sedan 1968-1972

"Thriftness is this Mini-Brute's strong point. Buts there is no pinching when it comes to essentials." 1970 selling manual.

Colors: Flame Red (RR), Spring Green (HH) and Chrome Yellow (YY) came with black interior.

Colors: Strato Blue (DD), Aztec Gold (GG) and Copper Bronze (WW) came with buckskin interior.

Colors: Brilliant White (CC) with red interior.

Note: There was also a 4 door version of this Kadett model with the model number 36.

Kadett - B, Engine Identification

1.1L, 1.1L-SR, 1.5L and 1.9L

All Opel engines can be identified by the first two digits of the engine serial number located on the middle drivers side of the engine block. The 1.1L is equipped with either a single one-barrel 35PDSI or two one-barrel 35 PDSI carburetors.

1.1L & 1.1L-SR with 4 speed transmission

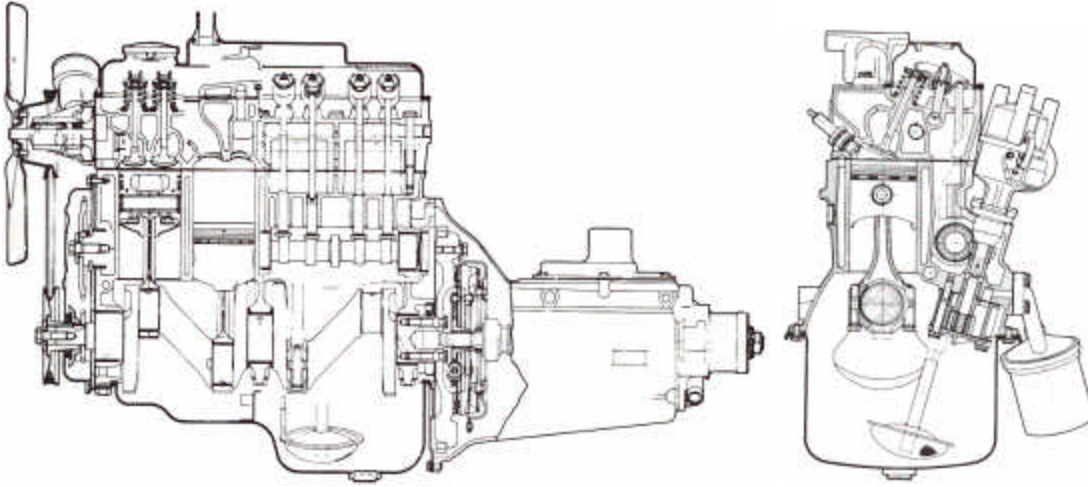

1.1L Visual ID:

1. The distributor is located on the drivers side of the cast iron engine block between cylinders 3 and 4.
2. The oil filter is located on the drivers side of the engine on an external bolt-on aluminum housing.
3. Spark plugs are located on the passenger side of the engine.
4. The cam shaft is in the block with the rocker arms being actuated via push-rods.
5. The starter is located low on the passenger side of the block.
6. The fuel pump is mount on the Drivers side of the block.

1.5 & 1.9L CIH engine

The 1.9L is equipped with a single two-barrel 32DIDTA.

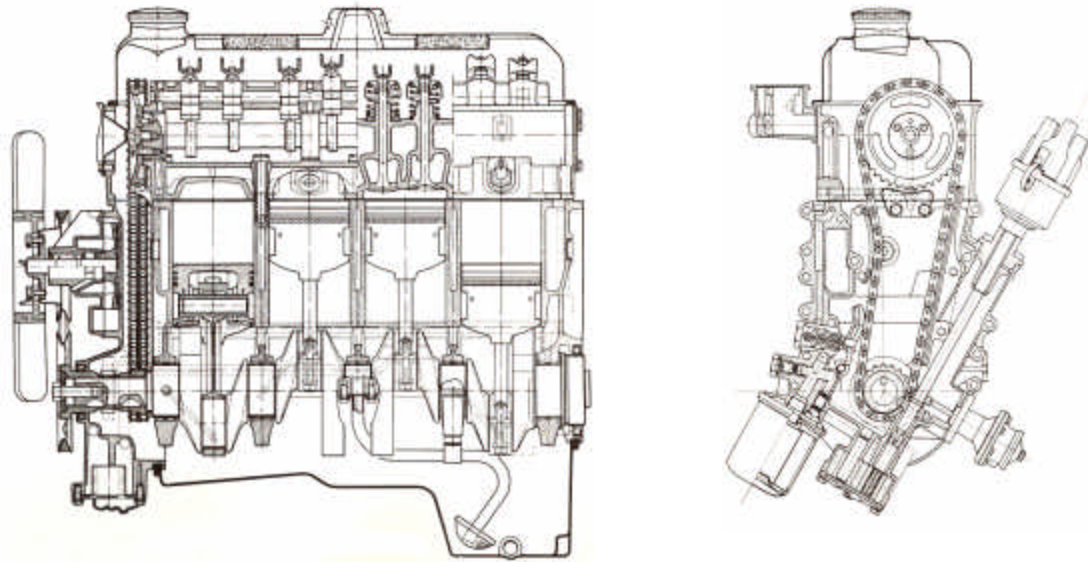

1.9L Visual ID:

1. The distributor is located in the aluminum timing cover.
2. The oil filter is located low on the passenger side of the engine on the aluminum timing cover.
3. Spark plugs are located on the driver side of the engine.
4. The cam shaft is in the cylinder head with the rocker arms being actuated directly via the lifters. (No push-rods).
5. The starter is on the driver side of the engine block.
6. The fuel pump is mount low on the drivers side of the aluminum timing cover.

Opel Kadett Suspension

We have the parts to get you back on the road.

3026-3029 Front suspension bushings
3025 Rear suspension bushings
3043 & 3044 Rear Spring Cups
3001 Sport Front Spring
3004 Sport Rear Coil Springs
3062 Intermediate Front Spring
3013 Upper Ball Joint
3014 Lower Ball Joint
3015 Inner Tie Rod

3017 Outer Tie Rod
3012 Rack & Pinion Boot
3021 Rack & Pinion Bushings
3045 & 3046 Rack Clamps
3048 Shock Repair Mount
3076 Bushing, Upper Susp. To Body Cup
3078 Leaf Spring Repair Kit

Plus many more items in the full-line catalog

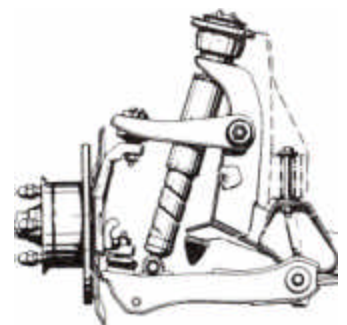

Opel Kadett

1967 1/2 Rallye version shown



Opel GT Source has been in business since 1987. As your Opel specialist we not only stock numerous items engine, transmission and brake items for your Opel Kadett, we have manufacture many discontinued suspension items, as well as import many hard-to-find items to aid you with your restoration project.

One of the first items that all 1.9L Kadetts need is a replacement for the old worn-out Solex carburetor. Opel GT Source offers both the Weber & EMPI carburetors to replace that unreliable Solex. Along with the carburetor we offer all of the appropriate gaskets, linkage adapter, Weber air filters, air cleaner adapter and even a cold air snorkel to build your own cold air system.

**Weber
32/36**

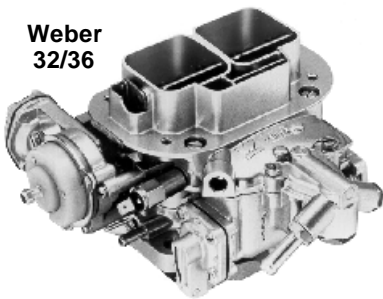

Opel GT Source also offers replacement and upgrade items for your 1.9L engine, ignition, suspension and braking systems. These items include the common wear items, as well as numerous performance upgrades. For example we offer polyurethane front and rear suspension bushings, for your Kadett.

We also import the larger displacement European 2.0, 2.2 and 2.4L Opel engines and Getrag 5 speed transmissions.

If you have been thinking How-To extract more power from your 1.9L we offer 2.0L pistons upgrades, larger 2.0L valves, 38 DGS Weber carburetors and performance cam shafts to substantially realize the performance potential of your stock 1.9L engine.



**Front and Rear
Polyurethane Suspension Bushings**

Opel GT Source also offers larger displacement European engines along with 5 speed transmissions. Engines offered are 2.0L, 2.2L and 2.4L cam-in-head (cih) engines. We also offer 2.0L pistons and 2.0L valves to convert your 75hp smog engine into a 110hp 2.0L. You can also opt to install a higher performance cam to extract even more power.



Left: 2.0L performance pistons and 2.0L valves

Left: Electronic Ignition System for your Kadett

Right: 2.4L European larger displacement engine, with the rare 2.4L valve cover.



We also sell 5 speed Getrag transmissions that bolt to any 1.9L to 2.4L CIH engine. The Getrag transmissions are quieter and stronger than the original 4 speed. The internal gears are almost double in size and 5th. Gear is a 0.805 overdrive ratio, which significantly lowers the RPMs on the freeway.

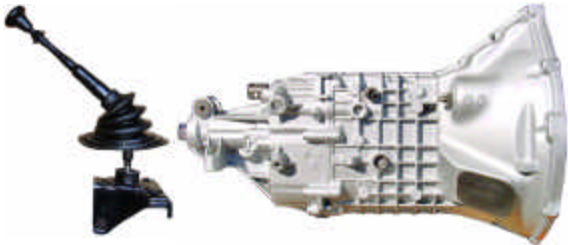

Getrag 5 speed and modified Kadett shifter

Want to eliminate the constant hassle of replacing your points every few thousand miles? Is your distributor worn? Consider eliminating the less than reliable points with an easy-to-install electronic ignition system. Fits into your stock distributor. Faster starts, better performance while you spend more time on the road, than under the hood.

Looking for a fender flare kit for your Kadett street-fighter? We've got you covered.

Below: 1970 Kadett with our Steinmetz fender flare kit.

European fuel injection, bigger brakes, heavier duty clutches as well as our expertise is available to upgrade or restore your Opel. Many other parts are available for our Opels that are described in detail in full line catalog and catalog supplement.

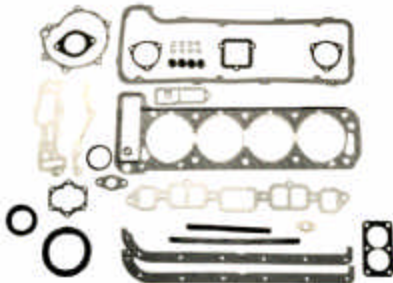

As always we not only sell parts, but we own and drive Opels. Please feel free to call us with your restoration needs.



GMOF EXCELLENCE
IN MOTOR DESIGN

1968-1972 OPEL KADETT



Impervious to desert heat,
invincible in trackless sands,
amazingly dependable from oasis to oasis.

The Mini-Brute

Buick's new Opel Kadett Deluxe Wagon. The economy import that provides so much low cost transportation for the price you'll wonder why you ever tried any other way.

This Mini-Brute boasts 55.65 cu. ft. of cargo space. (Enough for an average sized refrigerator, plus.) A new tougher suspension

with an anti-sway stabilizer bar and a powerful 55 hp. Engine with beefed-up drive-train are only a few of the things that deliver American style riding comfort.

There are five other Opel Kadett models this year. The Rallye Kadett, LS Sport Coupe, Deluxe Sport Coupe, 2-door Sport Sedan

And 2-door Sedan. All feature a long list of comfort and convenience equipment and the new GM safety package. They're at your Buick-Opel dealer now, in over 1600 locations across the country.

This week, see for yourself how great the new style in economy can be.

Buick's New Opel Kadett

GENERAL MOTORS' LOWEST PRICED WAGON