

Opel GT Heating Notes

Optimum heating within the Opel GT requires maximizing the available coolant flow within the heater core, while operating within a temperature range that is safe for the engine. Necessary service includes periodic back-flushing of the cooling system (some use Prestone's "Flush & Fill" home-use kit) & replacement of the heater valve (when clogged with dirt & rust).

Opel GT Source offers parts which can help, including:

Opel GT Heater System parts

11003 90-Degree Heater Hose
Connects Thermostat Housing to Heater Valve

11024 Gasket
Heater Box tubes to chassis. Rubber.

11031 Heater control valve
High Quality Reproduction. Includes Clip.

11031C Heater Cable Clip
(holds cable to 11031 valve)

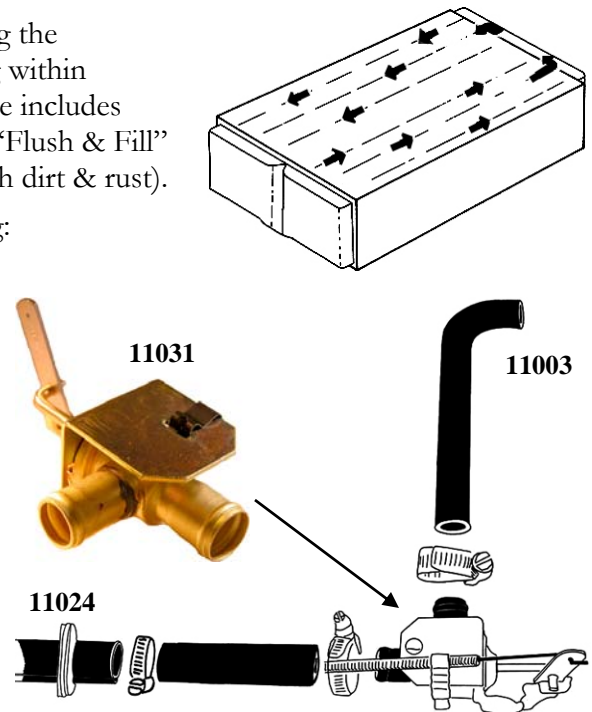

Opel GT Heater Control Panel parts

Slide the lower control lever on the dashboard heater control panel —if the lever on the engine-area heater valve doesn't move, the brittle plastic rear mounting bracket behind the dash has probably broken off. We suggest replacement of the original plastic heater control panel on the dash with a metal reproduction (which will last virtually forever). Replacement heater control lever cables are also now available as well.

11030 GT Metal Heater Control Plate
High Quality Reproduction
(now sold at a new lower price!).
A must for every driver GT!

11032 Heater Control Cables (set of 2)
(from control panel to air and heater valves)

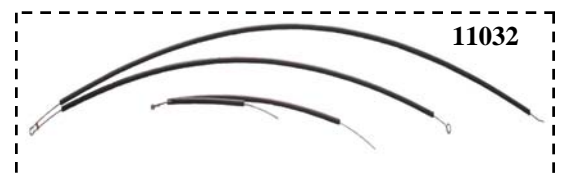

Under-Dash View

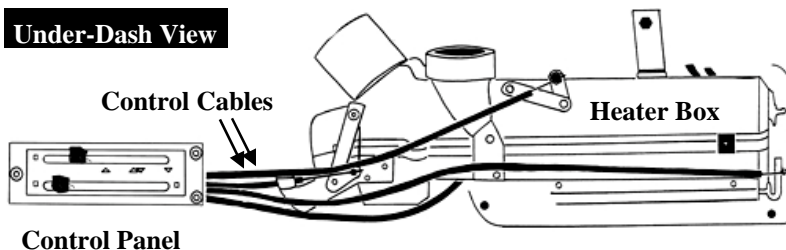

Heater Box

It's a good idea to perform internal heater box service (such as cleaning interior flaps and fan blades) whenever the windshield or dash are removed (such as when a car is painted).

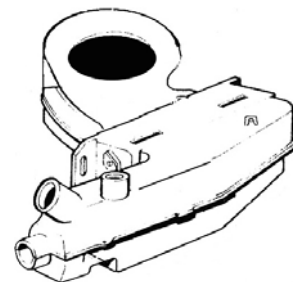

For maximum heating, we also recommend professionally cleaning your radiator & upgrading the cooling system (with a replacement fan blade and other parts), as greater cooling system efficiency can allow seasonal use of a hotter thermostat (which can also increase the temperature of the coolant circulating within your heater core).

Opel GT Cooling Notes

Cooling system maintenance and performance is important to engine durability.

Optimum streetability for carbureted Opel engines is to run at about 185F.

Sustained operation at temperatures above 212F adds a significant risk of internal engine warpage (particularly on engines with 12-bolt style cylinder heads originally installed on 1973-1974 Opel engines)

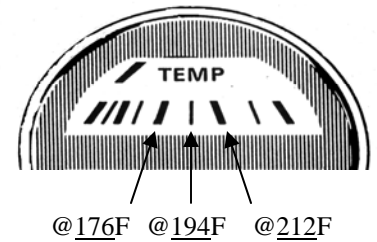

Opel GT Source Cooling Specials

The Opel GT radiator can run hot due to its tight underhood space with limited airflow.

Our *Underhood Rubber Strip Set* helps, by forcing cooler air where it is needed:

Through the radiator (instead of around it). It also helps seal engine fumes from your air vents (keeping you cooler when driving). #6037

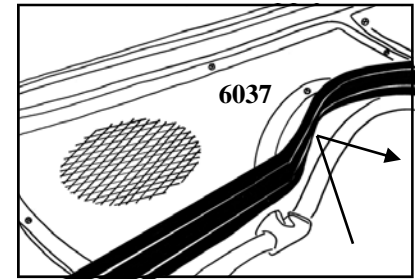
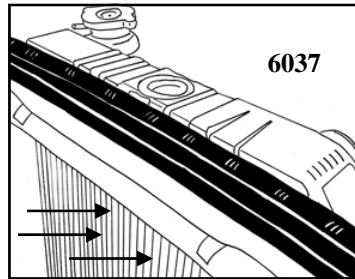

Original Opel GT fan blades were made of a brittle plastic, which after 40 years of age and exposure have become less effective.

Our *Reproduction Fan Blade* bolts-on the same as the original 7-blade 1.9L design, and will restore the cooling that has been lost due to warping and breaking of old blades. #11025

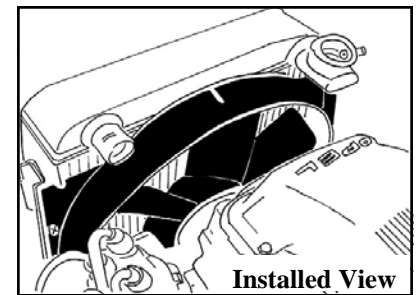

Opel GT Source Maintenance Parts

Opel GT Sources stocks an extensive line of New common-duty replacement parts for the Opel GT 1.9L Cooling System, including:

11001 GT Upper Radiator Hose

11002 GT Lower Radiator Hose

11006 Water Pump (w/gasket)

11008 Radiator Lower Support Bushing

11013 Fan Belt

(identify style for correct length)

11020 Radiator Cap

(aftermarket style)

11035 GT Radiator Mounts

(set of 2, attaches at bracket sides)

11005 Thermostat

(Select your heat range)

6013 Gasket, Thermostat to Housing

6014 Gasket, T-stat Housing to Cyl Head

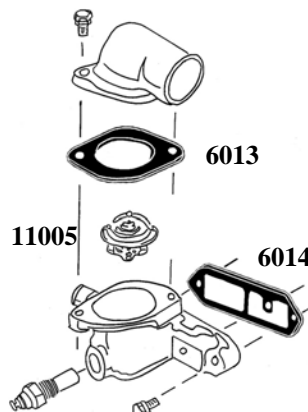
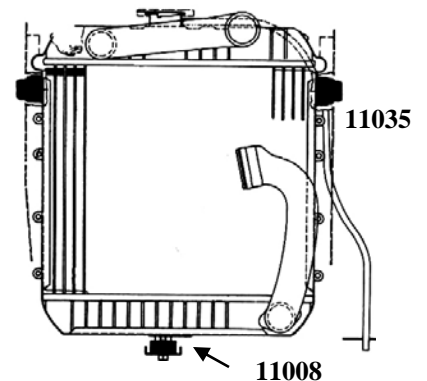
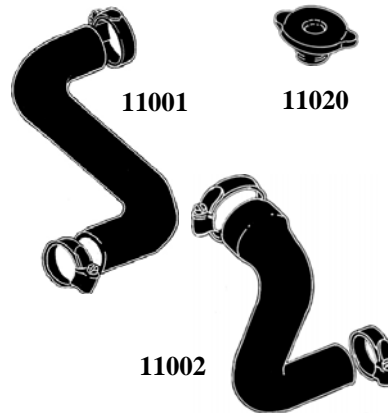

Performance-built radiators are also available (as special-order items)

Additional details are on our website listings