

OPEL

GT

SOURCE

Digital Catalog v. 2.1

OPERA  
GT

## Our Mission

Opel GT Source was founded by Opel enthusiasts, and continues to be run by Opel enthusiasts who own and drive Opels regularly.

Opel GT Source's passion for Opels is reflected in our philosophy and our practice. We will only sell parts that we would put on our own cars!

Our passion extends to the myriad of new production and high-performance parts that we offer.

When you view the inventory listed here, you will see many parts that you won't find elsewhere. This is because Opel GT Source has consistently re-invested its proceeds from Opel parts sales into the production of new parts for the classic Opel GT (as well as the Opel Manta/1900 and the Kadett B). Our parts program adds many new products each year, as evidence that we are committed to this specialized market. So when you make a purchase from Opel GT Source, you are actually making an investment in your own car's future parts availability. We have been in business full time since 1987, however our passion for these cars has been strong since the 1970's. Our first cars were Opels and they still are as interesting to us today as they were in our early years of Opel ownership.

Opel GT Source maintains a substantial inventory of hard-to-get Opel items, organized in our parts warehouse. We maintain our own facilities, which helps us to keep our parts prices low (in many cases, some of our parts have been sold at the same prices for over a decade).

In addition to our excellent inventory and everyday low prices, you can count on us being there to answer the phone during our business hours. Rarely if ever will you get an answering machine during our regular hours. We make sure to promptly answer all emails, faxes and phone calls for some of the best customer service in the industry. Most importantly to you the customer, for over 30 years we have maintained a same-day shipping policy (with orders placed by noon), so that the parts you need are only a phone call away. We choose the best value shipping service to help you get your parts fast and economically.

These are some of the benefits you will receive, when you shop with Opel GT Source (as compared to corporate "big box" stores or online re-sellers, who tend to redirect Opel part revenues and re-stock with easier-to-sell Chevy or Toyota inventory). We invite you to check our reputation with any of our thousands of customers (many of whom post their experiences on online forums).

Our re-investment extended to the production of this guide, which is designed to provide you with hard-to-find Opel information (so you can order and receive the correct parts you need, the first time). Many of our parts also come with installation instructions, including custom-written technical guides and diagrams (that help fill-in what the various Opel service manuals should have told you), so your repairs can be done right, the first time you do them. You can call, fax, or e-mail us, regarding your Opel part needs, and we look forward to serving you for many years to come.

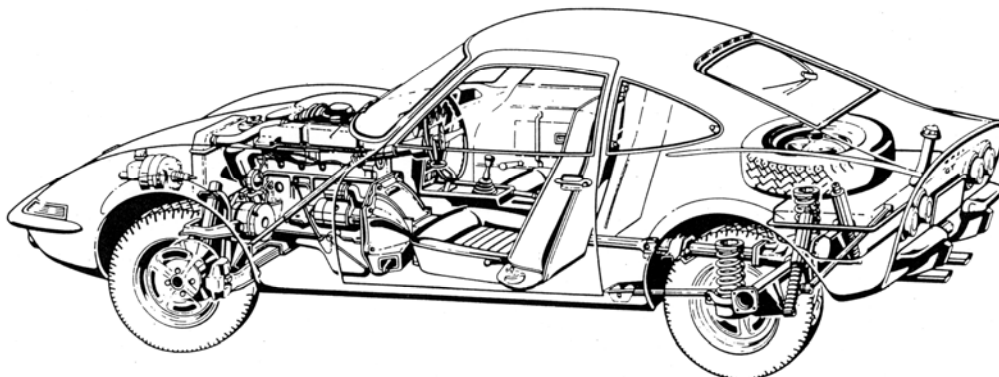

*“We will only sell parts that we would want to put on our own cars!”*

**Better Parts  
+ Better Service  
Better Performance**

**The Opel GT Source Way**

# Contents

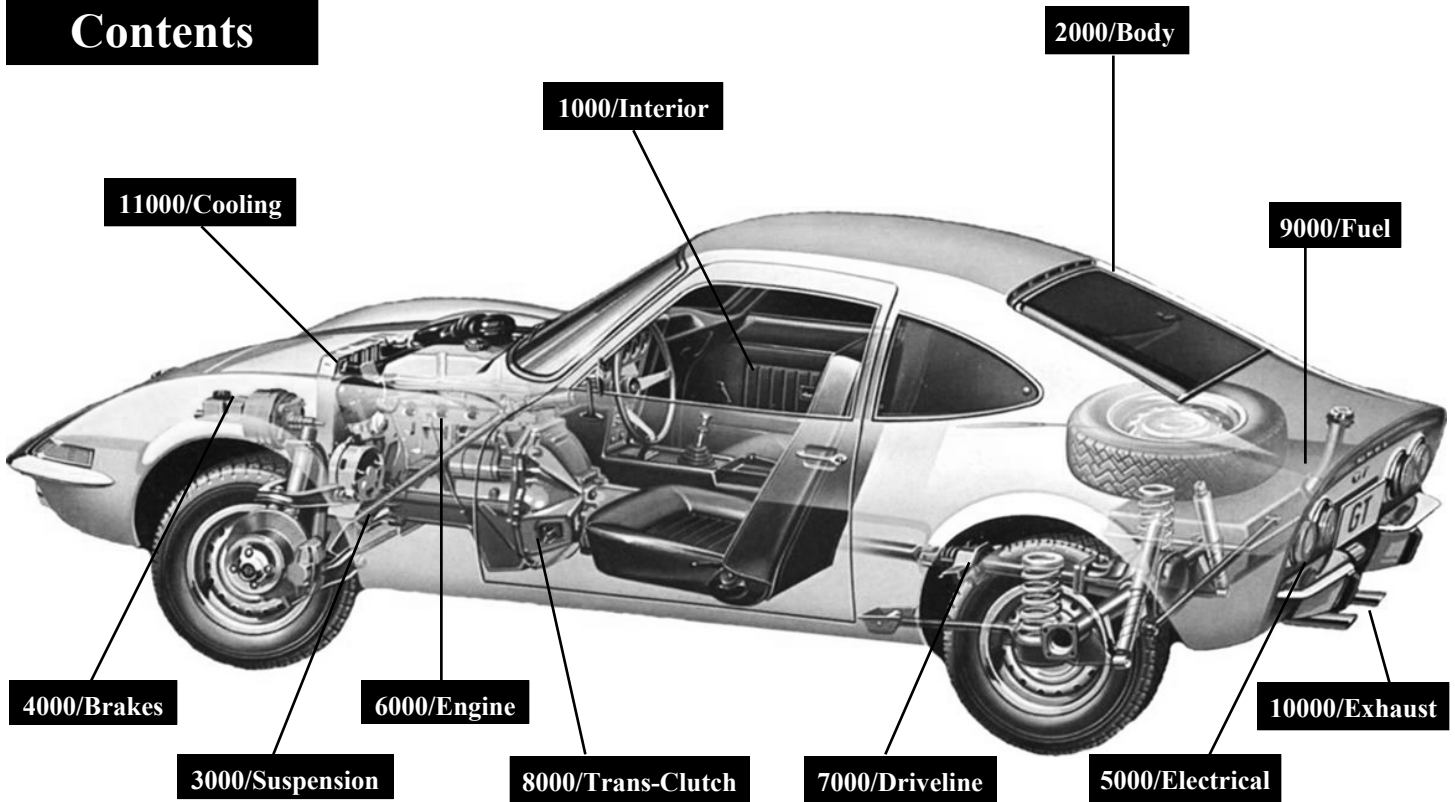

12000	Emblems and Accessories
13000	Part Rebuilding Services

14000	Books and Literature
14000	Document Policies

*NEW parts offered by Opel GT Source for classic 1968-1973 Opel GT's are listed on the following pages, in sections that are numbered (per the illustration above).*



## Need Used Parts?

In addition to a large inventory of new and performance parts, Opel GT Source also has an inventory of many various good used components to fit classic 1968-1975 Opels.

*It's important to plan your order by identifying the model and year of your vehicle application, and also to be aware of part variations (which occurred between models and years).*

*You can also view photos of our individual parts, on our website at:*  
[www.opelgtsource.com](http://www.opelgtsource.com)



Carrier shipment locations

## Opel Models (US Exports)

Almost a million vehicles were marketed under the “Opel” name, by Buick dealers in the USA from 1957-1980.

Most of the surviving export models were produced by Opel of Germany from 1968 through 1975, which includes:

### **Opel GT 1968-1973**

**Opel Kadett 1968-1972** (Sedan, Fastback, Wagon and Rallye),

**Opel 1900 series 1971-1975** (Manta, Rallye, Ascona Sedan, Wagon).

*Many parts for Kadett and Manta/1900 series are shared with the GT. (Others can be located at our website, at <http://www.opelgtsource.com>)*

(We do not stock parts for the 1976-1980 “Isuzu” manufactured Opels, or earlier 1957-1962 Rekord/Olympia models).



### **This Part Catalog is compiled for Opel GT's**

*Many of the parts listed here for the 1.9 engine version of the Opel GT (suspension, brakes, engine, transmission, driveline and cooling system) will also apply for the 1.9 version Kadett and Opel 1900/Manta series.*

Owners of other Opel vehicles, like the Opel Manta & Kadett, are advised to view “digital catalogs” within “tips” on our website at [www.opelgtsource.com](http://www.opelgtsource.com)

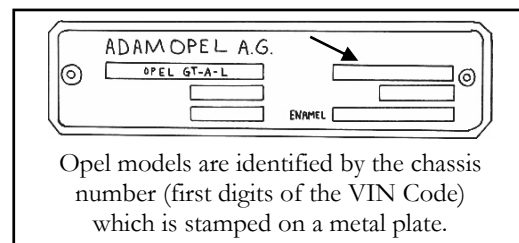

Opel models are identified by the chassis number (first digits of the VIN Code) which is stamped on a metal plate.

### **What Model and Year is Your GT?**

The VIN code, was used to number the beginning of each model year. (Also described, are “quick glance” clues commonly seen)

1968: Very Rare

(Indicated by date codes preceding 8/68, on rear of dash gauges)

1969: VIN Codes start with 94-1535504

(Instrument panels have “angled” indicator lenses and 2 front screws )

1970: VIN Codes start with 94-1888188

(Instrument panels have round indicator lenses and 2 front screws)

1971: VIN Codes start with 77-2265862

(First year of the “popout” side opening windows)

1972: VIN Codes start with 77-2560567

(Some dash switches have writing instead of universal symbols)

1973: VIN Codes start with 77-2944586 (dash/door prefix is “OY07NC”) (“Cross shaped” wheels and “split lens” rear lights appeared after 1/1/1973)

(Note: Some rare 1968-1970 1.1L engine GT's VIN codes started with “93”)

**For additional details on GT model years, including samples of original Opel GT Paint Colors: Visit the “tips” pages of our website**

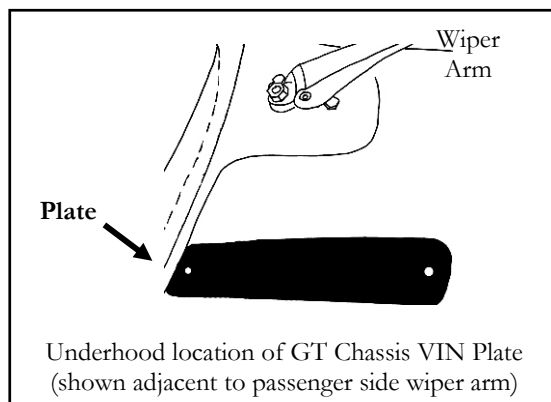

Underhood location of GT Chassis VIN Plate (shown adjacent to passenger side wiper arm)

**Chassis No 772667872**

A plate with VIN code also appears on the dashtop.

Unlike US-produced cars, Opel engines had their own separate (non-related) serial number.

More information about Opel GT model-year changes can be found online at [www.opelclub.com](http://www.opelclub.com)

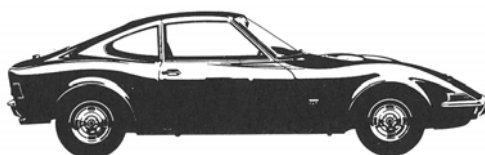



# 1000/Interior Parts



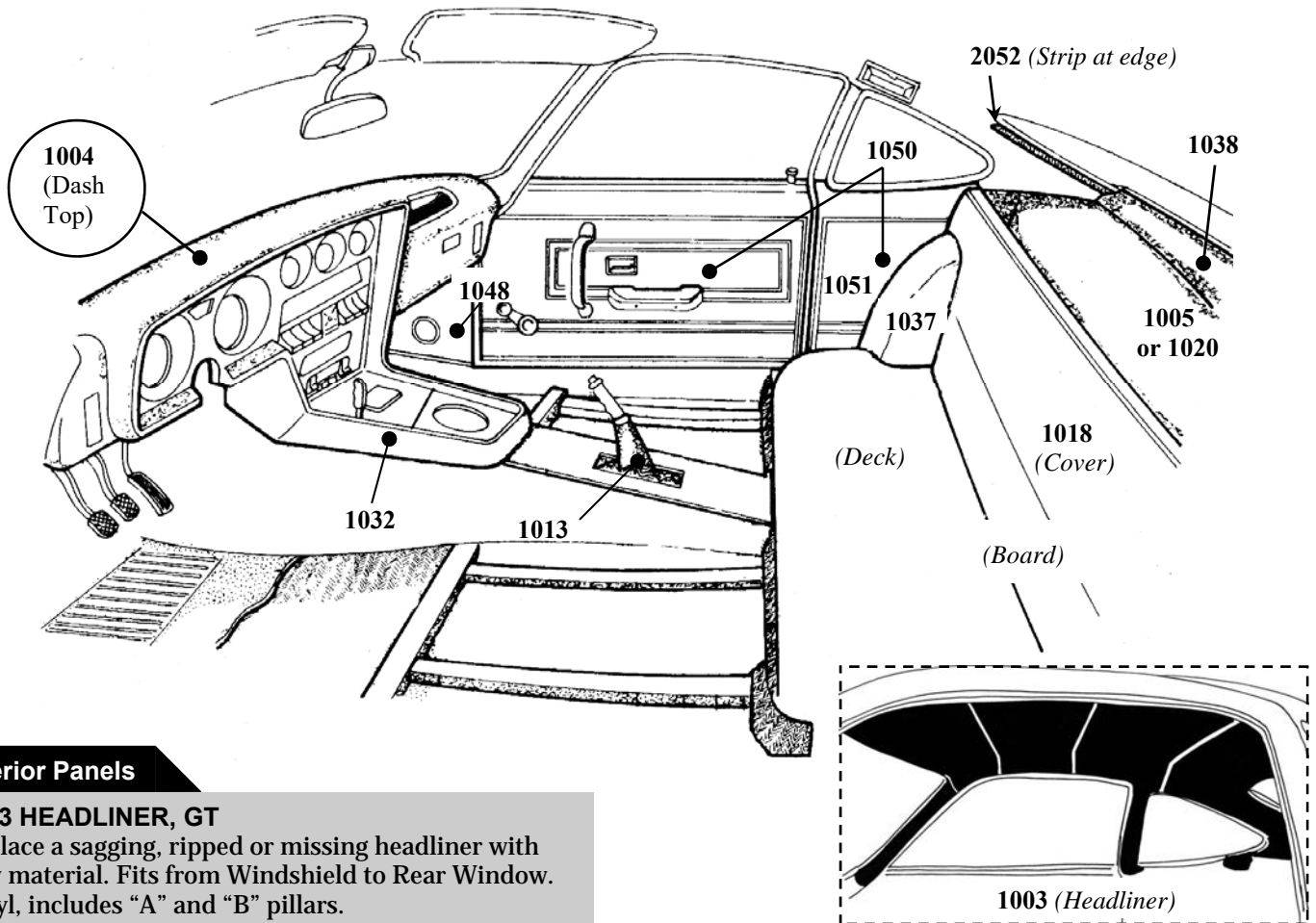

## Interior Panels

### 1003 HEADLINER, GT

Replace a sagging, ripped or missing headliner with new material. Fits from Windshield to Rear Window. Vinyl, includes "A" and "B" pillars.  
*Specify Black, Off-White, Red or Tan color.*

### 1004 DASHMAT FRONT, GT

A fine form-fitted cover that helps shield the driver and dash from heat and glare. Also the most cost-effective and easiest remedy to hide the sight of a cracked top dash.  
*Specify Black, Tan or Red color when ordering.*  
Additional Colors available as Special Order Items

### 1005 DASHMAT REAR, GT

Fits inside Rear Panel below the Rear Window  
Located above spare tire and below the rear glass.  
*Specify Black, Tan or Red color when ordering.*  
Additional Colors available as Special Order Items

### 1013 PARKING BRAKE BOOT, GT

Stitched Vinyl sleeve which surrounds brake lever.  
*Specify Black, Tan or Red, when ordering*

### 1018 SPARE TIRE COVER, GT

Cover flap which hangs over the back shelf & spare tire.  
A fine replica of original, Interior restoration part.  
*Specify Black, Tan, Red, or Off-White color*

### 1020 REAR PACKAGE TRAY, GT

Replica of original horizontal panel in Vinyl, located above spare tire and below the rear glass.  
Includes pre-cut speaker hole in backing board to allow option of adding a speaker. Installs in minutes  
*Specify Black, Tan, Red, or Off-White color*

### 1032 CENTER CONSOLE COVER, GT

Vinyl Stitched, allows you to re-upholster your console.  
*Specify Black, Tan or Red color when ordering*

### 1037 REAR WHEEL WELL COVER, GT

Vinyl. Sold as a Pair. Interior Restoration part.  
*Specify Black, Tan, Red, or Off-White color.*

### 1038 WINDOW ARCH, GT

Vinyl-covered strip in lower window area,  
Fits behind 1020 package tray.  
*Specify Black, Tan, Red, or Off-White color*

### 1048 FRONT KICK PANELS, GT

Replace your scuffed or worn-out panels, with this pair of vinyl covers on fiberboard backing, with vent holes.  
*Specify Black, Tan or Red color when ordering.*

### 1050 DOOR & SIDE PANELS, GT

Opel GT Door Panel & Quarter Panels, Set of 4  
Driver's Side door includes map pocket (1970-73).  
Recommended w/ #1041 grommets & #1045 clips  
Core Exchange of Your Used Door Panels required

### 1051 SIDE PANELS, GT

GT 1/4 Panels, Vinyl, 1 pair, Contact us for availability

### 2052 REAR TRIM STRIP, GT

Rear headliner edge at rear window.  
Secures headliner at rear window vents. *Black.*

1004  
or 1023  
or 1025  
(Dash Top  
Options)

The typical Opel GT dash is now over 40 years old, and has a top surface that shows cracks, or broken-up material. Opel GT Source offers a choice of dash-top solutions including: a dashmat top cover, or larger-scale options such as a Dash Cap or a Vinyl-Stitched Reupholstery Dash Cover.

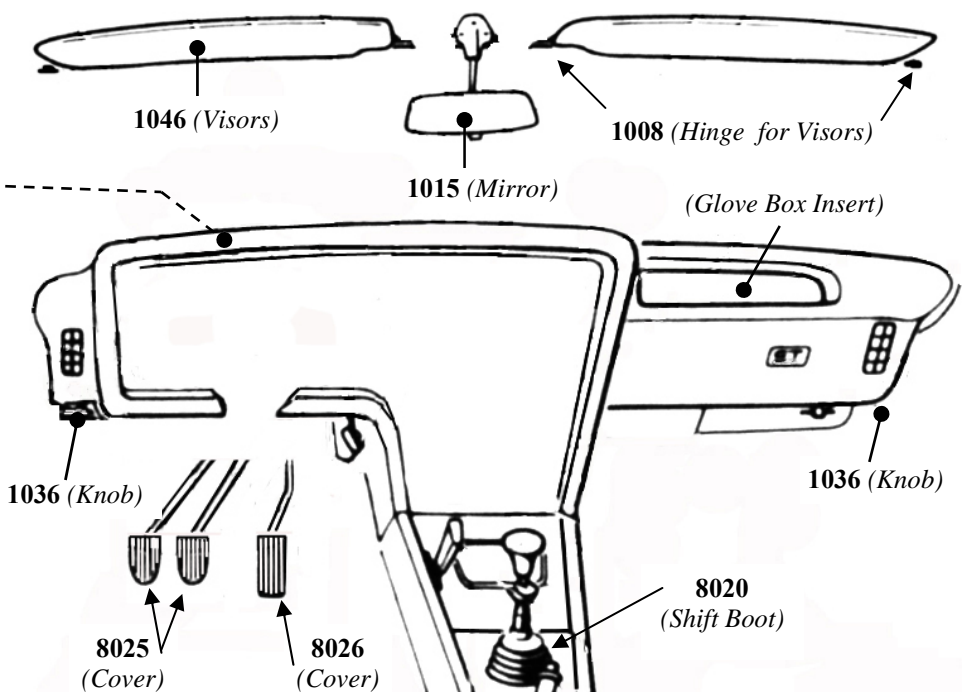

**Dash Top Choices**

**1004 DASHMAT FRONT, GT**  
A fine form-fitted cover that helps shield the driver and dash from heat and glare. Also the most cost-effective and easiest remedy to hide the sight of a cracked top dash. *Specify Black, Tan or Red color when ordering.* Additional Colors available as Special Order Items



1004 (Dashmat)

**1023 DASH CAP**  
Form-fitted ABS plastic, black. Covers tops and front of dash pad. Excellent for hiding cracks. *Installs in minutes, a good solution when vehicle is mostly stored where it is out of the sun.*



1023 (Dashcap)

**1025 VINYL STITCHED DASH COVER**  
Covers entire dash pad. Designed to be stretched and glued into place with dash pad removed from car. *NOTE: Dash cracks must be smoothed and filled before installation.* Specify Black or Red when ordering. Additional Colors available as Special Order Items



1025 (Cover)

**Dash Area Parts**

**1008 VISOR HINGE**  
Select Color: Black, Red, Tan, or Off-White  
Note: Two (2) hinges required per visor, four per car

**1015 GT INTERIOR MIRROR**  
New Reproduction, Includes Mount Plate and Stem

**1036 KNOB, GT DASH VENT**  
Knob, German reproduction of the Opel GT dash vent air vent slide control.

**1046 GT SUN VISORS, ONE PAIR WITH HINGES**  
Reproduction. Select color: Black, red, tan or off-white

**1061 GLOVE BOX INSERT**  
Aluminum. Special Order: Contact us for availability.

**2044 TRIM SCREW**  
Trim screw for GT dash pad. (10x required on a GT)

**2053 STEERING COLUMN SHEAR BOLT**  
Features original "twist-off" head design

**DASH VENT DUCT HOSES**  
New items. Inquire for details



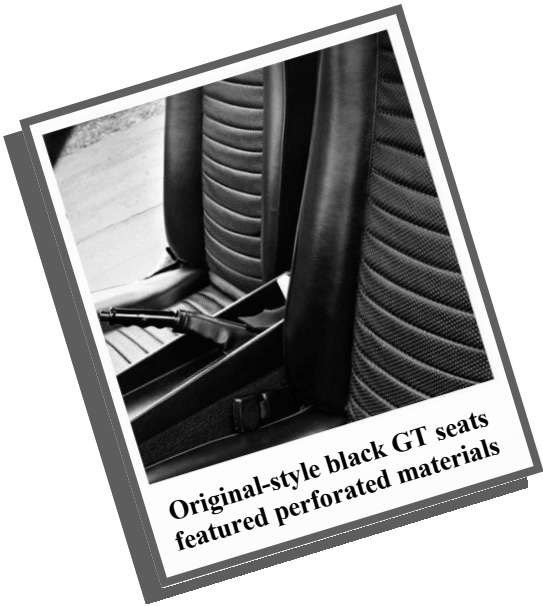

**Original-style black GT seats  
featured perforated materials**



*In many cases, you can bring your  
GT's interior back to its original beauty.  
Opel GT Source offers a selection, from just a few  
needed wear items to a complete interior restoration.*

### Seats & Hardware

#### 1010 GT SEAT UPHOLSTERY, VINYL

A high-quality reproduction of the original Opel GT seat upholstery. Made from high quality vinyl, french stitched, zipper rear flap. Sold as a pair. A must for all GTs.

*Choose color: Black, Red, Tan & Off-White.*

#### 1026 RECARO SEAT ADAPTORS

Opel GT. Two (2) required. Sold individually.

#### 1031 SEAT HINGE REPAIR BOLT

Special bolt helps to repair broken GT seat hinge.

### Seat Belt Kits

#### 1033 SEAT BELT KIT

Do you have missing, damaged, old or just plain un-safe original seat belts? Would you like to modernize your GT and increase safety? Then this kit is your solution. You can convert your old and worn two piece seat belts into a single 3-point seat belt. One kit does one seat. Features smooth, unrestricted movement while buckled in, yet locks up firmly when they need to.

*Recommended for 1970-1973 GT's, which have  
or can be adapted for a floor mount  
(not recommended for 1968-69 models with shoulder  
belt mount located below the quarter window).*

**1033**



### OPEL GT SEAT BELT NOTES

1970-1973

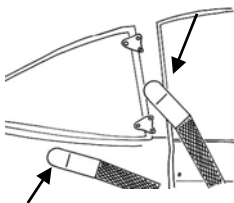

1968-1969

*There were 3 designs of seat belts originally installed in Opel GT's.*

*In 1968-1972, this included separate shoulder belts and lap belts.*

*(In 1968-1969 the shoulder belt mounted below the quarter window,  
and this mount was relocated in 1970-1973 to the B Pillar)*

*In 1973 "Y" design belts had a retractable reel & plastic buckles*

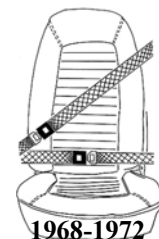

1968-1972

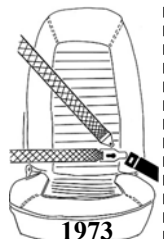

1973



**HQ Floor mats**  
Part #1028 (pair of 2)

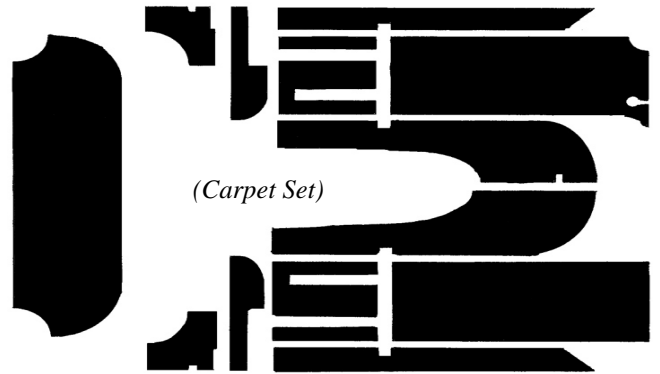

**Carpets & Floors**

**1001 COMPLETE CARPET KIT, LOOP**  
Includes every piece of carpet in a 1970-1973 Opel GT. New reproduction, patterned after the original factory design, with special backing that is die-cut, featuring correct heel-pad and tunnel areas in proper original vinyl. Standard colors in stock are Black, Red and Tan. Easy install, greatly improves quality of your interior!

**1014 CENTER REAR CONSOLE CARPET**  
For 1969 Opel GT's without plastic center rear console. Choose red, black or tan color.

**1016 SPRAY ADHESIVE**  
New larger can. Spray adhesive for installing the carpet kit and/or padding.  
*Note: Ships by UPS Ground only.*

**1017 CARPET PADDING**  
Padding for under the carpet kit, must be cut to size. Helps keep road noise out of the car and makes the carpets feel more comfortable.

**1028 HIGH GRADE FLOOR MATS**  
Rigid, made of quality loop carpet with thick rubber backing and vinyl edging. Choose black, red or tan. Pair

**2030 FLOOR PLUG**  
Round rubber floor drain plug.  
Ten (10) required per car.

**CARPET & FLOOR NOTES**

*Replacing the carpet in an Opel GT is one of the most noticeable improvements you can make, and typically results in a big difference in your perception of the quality of the interior of the car.*

Opel GT Source's carpet sets include every piece of carpet originally installed in the 1970-1973 Opel GT's (some 1969 GT's also had a separate piece, around the parking brake). Our carpets are designed to reproduce the original "loop" style carpet appearance and material once installed.

*When an original carpet is removed is the best time to also service or upgrade the floor area. Many owners choose to add a layer of soundproofing materials (such as Dynamat or lower-cost alternatives) or undercoating, as well as to service floor pans and/or replace rubber floor plugs, as may be required..*

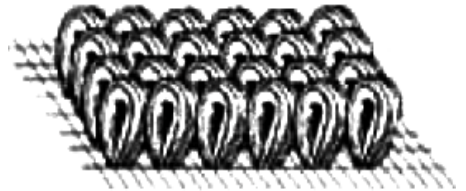

**"Loop" material**  
Original style



## Interior Parts

### 8020 GT SHIFTER BOOT

Reproduction. Keeps heat, exhaust fumes and noise out of interior of car. Exclusive OGTS product made from high quality military spec neoprene for long life and durability. Stretches over original trans knob.

### 1024 PLASTIC RING INSERT

Fits around base of 8020 boot in console.

### 1062 ASHTRAY REPAIR KIT

New replacement black plastic handle, which Mounts in position on slider lid of a used ashtray. Import item.

### 4069 BRAKE PEDAL SPRING

Helps raise brake pedal for improved operation

### 8025 BRAKE or CLUTCH PEDAL RUBBER PAD

Rubber pad that fits over your brake or clutch pedal. Manual transmission

### 8026 ACCELERATOR PEDAL RUBBER

Rubber pad that fits over your accelerator pedal.

### 12030 BULB

Rubber bulb that fits inside washer pedal

### 12030A STUD

Stud Mount that secures rubber bulb inside pedal. Replaces rusted-out original hardware.

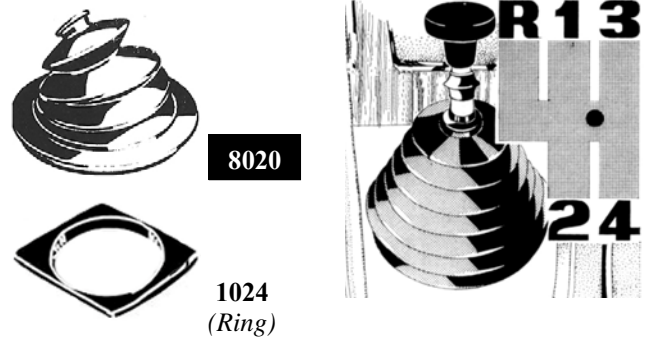

12030 (Bulb)

12030A (Stud)

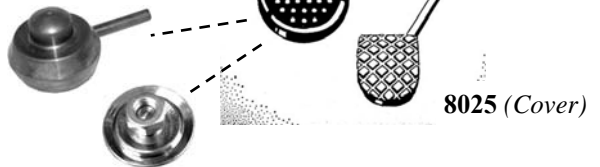

## Dome Light Parts

### 5001 DOME LENS

Brighten up your interior by replace your old yellowed and dingy dome lamp lens with our brand new lens.

### 5001B DOME LIGHT BASE

Metal Mount with switch assembly for light.

### 5076 DOME LIGHT BULB

For GT & Kadett dome lamp base.

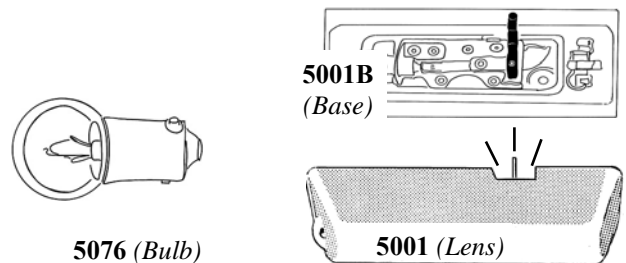

## Steering Wheels & Parts

### 1059 OPEL GT STEERING WHEEL

Reproduction of original walnut-shade GT wheel  
(Can be viewed on website, [www.opelgtsource.com](http://www.opelgtsource.com))

### 1060 OPEL GT STEERING WHEEL

Reproduction featuring darker mahogany-shade  
(Can be viewed on website, [www.opelgtsource.com](http://www.opelgtsource.com))

### 1022 RAID STEERING WHEEL COUPLER

RAID steering wheel adaptor for Raid steering wheels. Will fit GT and Manta models.

NOTE: It will not work with Grant steering wheel unless you fabricate your own adaptor plate.

### 1029 MOMO STEERING WHEEL ADAPTOR (coupler)

For GT and Manta, there are many MOMO steering wheels to choose from.

### 1039 ADAPTER, GRANT STEERING WHEEL to MOMO COUPLER

This adapter allows you to install a Grant steering wheel on a 1029 Momo steering wheel coupler.

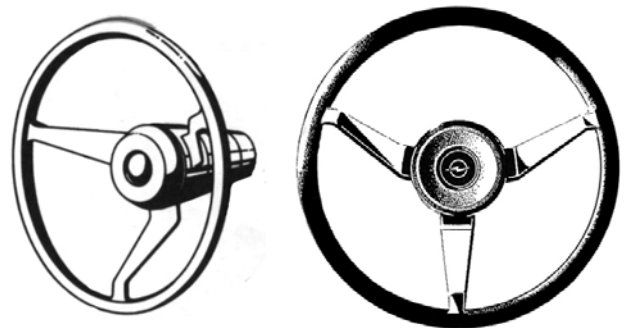

## Interior Notes

A popular weekend project is an upgrade of the Opel GT interior, including replacement of individual parts, interior panels, and/or carpets. You can reward yourself with attractive results that will give you an improved feel about your surroundings whenever you drive the car, for many years to come. Opel GT Source helps by providing high-quality parts, many of which also come with installation notes.

You can get started by checking your interior, then letting us know what your needs are.

### Original Interior Identification

Most Opel GT's featured a black interior but some Opel GT's came with an off-white, tan, or red colored interior. There were also some model-year variations in interior components such as seat belt designs and carpet layouts and with accessories like an automatic transmission or air conditioning system.

### Critical Connectors

Many Opel GT Interior Panels are backed with thin fiberboard that is secured with special clips, and other hardware such as the dashpad, steering column and seats also have unique connector pieces. In any event, we advise viewing our "tips" to learn "safe" approaches for dealing with these connectors and fragile interior pieces and panels, prior to disassembly.

### Related Part Upgrades

Another popular approach is to combine interior projects, such as adding soundproofing materials when carpets or floor pans are replaced, or performing heater service or a headliner replacement (when paint/body work is done). For the best fit and finish, we do advise professional consultation on critical items like headliners, seat upholstery and dash re-covers.

### Warm Working Area and Interior Parts

For best results, make sure replacement interior parts such as the headliner and other vinyl pieces are warm prior to assembly. Working in a warm area also helps to ensure optimum fabric pliability. For added comfort, consider memory foam on backs and lower areas of seats.

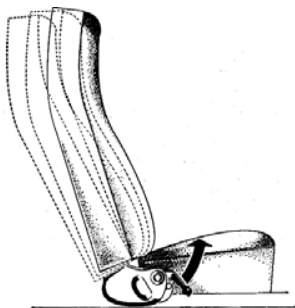

*Check seat frames  
for latching function*

*You can view original  
interior colors and other  
interior variations within  
the "tips" section of the  
Opel GT Source website, at:*

*[www.opelgtsource.com](http://www.opelgtsource.com)*



*"Clip/Hole"  
Attaching  
hardware*



*Interiors are  
best installed  
in a warm room*



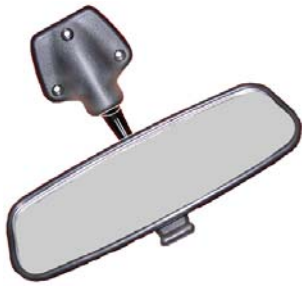

**1015 Interior Mirror**  
Clear Glass in a new plastic housing  
*Fits original Opel GT mount holes*



**5001 & 5001 B Dome Lens & Base**  
White Plastic Lens & Metal Base  
*Replaces faded or broken assemblies*



**1046 Visors**  
Vinyl. Sold as a Pair. Includes Hinges.  
*Select: Black, tan, red or off-White*



**Used Interior Parts also available**  
*Email Opel GT Source with your needs*



**1059 Opel GT Steering Wheel**  
Reproduction in original walnut shade.  
*Helps complete interior restoration.*



**8020 Shift Boot**  
Original Opel GT design.  
*Helps keep heat & fumes out of interior.*



**11030 Heater Control Plate**  
Solid Metal. *Helps restore heater function from the inside of the car.*

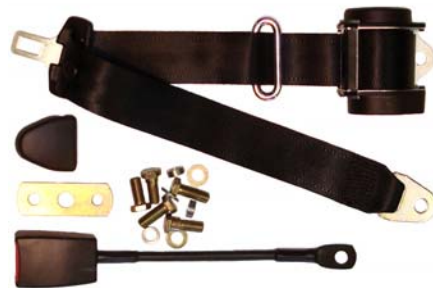

**1033 Seat Belt Kit**  
Replacement for worn/missing belts  
*3-Point design, installs on 1970-73 GT's.*



**1010 Seat Covers**  
Vinyl, Original Design  
*Select Black or Color.*

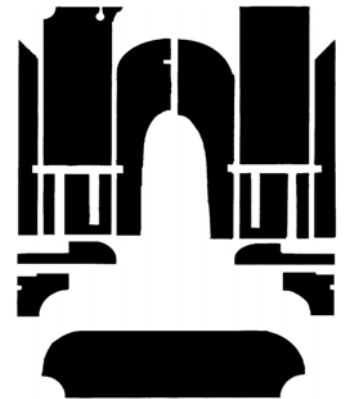

**1001/1002 GT Carpet Sets**  
Quality Material with Seamed Edges  
*Loop or Cut Pile. Install notes available*

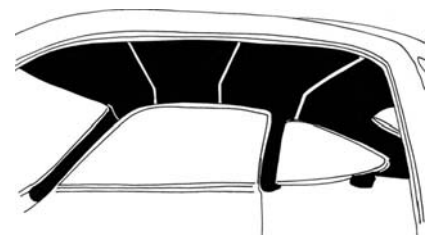

**1003 GT Headliner**  
Solid Vinyl with stitched seams  
*Select Black, Tan, Red or Off-White*

## 2000/Body Parts





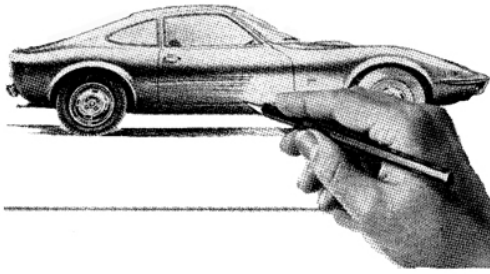

The attention and questions you get (everywhere you go) are confirmation: More than forty years after its introduction, the GT has remained “forever young” as one of the most uniquely attractive classic cars you can drive.

*Restoring the body exterior, including a paint job in the color you’ve always wanted, is your opportunity to return your GT to its original beauty. For best results, Opel GT Source offers reproduction window moldings and body trim, to help you achieve that “new car look” again.*

### Front Window Rubbers

**2001 GT A/L WINDOW CHANNEL, FRONT**  
Front window rubber with groove to install chrome strip (2010).  
Original Opel GT design, Reproduction item.

**2011 GT/J WINDOW CHANNEL, FRONT**  
Front window rubber without a groove, that is solid rubber with no place for chrome. Gives your car a European "Cafe Racer" look!  
Reproduction item.

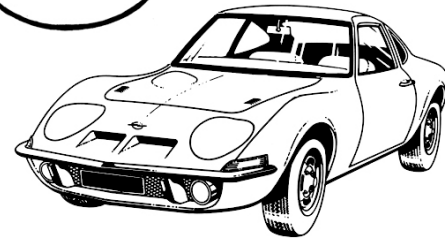

2001 (GT A/L)  
or  
2011 (GT/J)

### Rear Window Rubbers

**2002 GT A/L WINDOW CHANNEL, REAR**  
Rear window rubber with groove to install chrome strip (2010).  
Original Opel GT design, Reproduction item.

**2012 GT/J WINDOW CHANNEL, REAR**  
Rear window rubber without a groove, that is solid rubber with no place for chrome. Gives your car a European "Cafe Racer" look!  
Best when used with 2011. Reproduction item.

2002 (GT A/L)  
or  
2012 (GT/J)

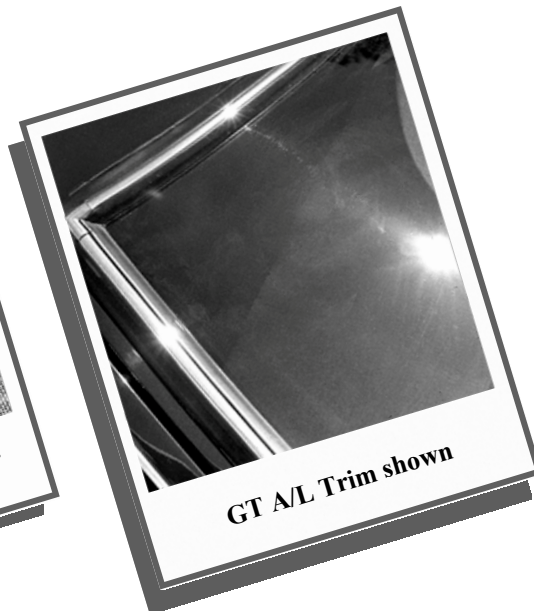
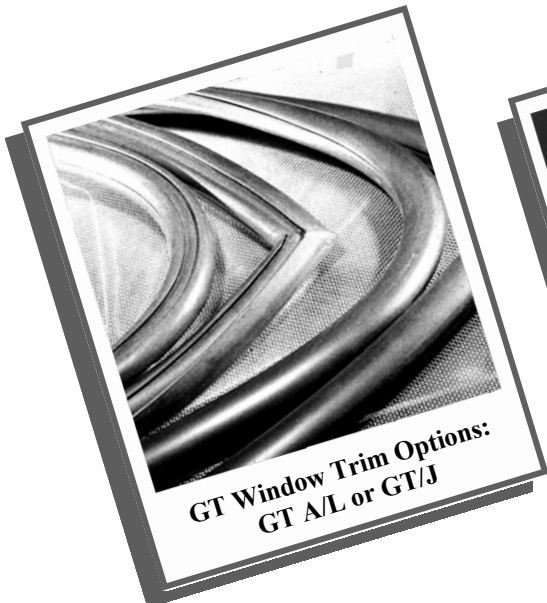
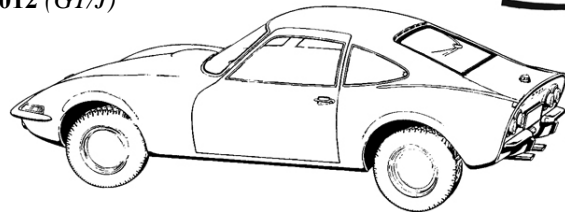
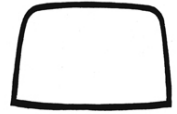

See GT A/L  
vs. GT/J Styles  
(Explained  
on Next Page)





## Original GT A/L style (Explained)

Original-export Opel GT's were of the "GT A/L" design, which included trim strips around each of the windows.

To accommodate this, exterior rubbers had an outer groove to fit this trim.

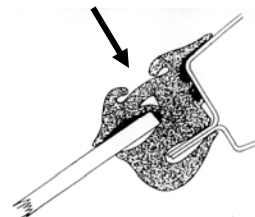

*Additional trim items include a plastic "chrome appearance" trim strip which is inserted into the front and rear window rubber, and sets of aluminized metal trim pieces around the door and also the rear side "quarter" windows (of varied 'fixed' and 'popout' designs).*

### GT A/L Front & Rear Trim

#### **2010 WINDOW LOCKING STRIP, CHROME**

Chrome-appearance locking strip for front/rear window channels. Installation tool available (2019). 22 feet roll for front/rear, original Opel part.

#### **2040 WINDOW LOCKING STRIP, BLACK COLOR**

Plastic locking strip same as #2010, but in black color. Provides GT/J appearance on original GT A/L rubbers

#### **2019 LOCKING STRIP INSTALLATION TOOL**

For inserting #2010/#2040 to front & rear windows

#### **12005 CHROME CORNERS**

Chrome Corners for front and rear windshields. German reproduction in stainless steel. Fits: 1968-73 Opel GT front & rear, 4 per car.

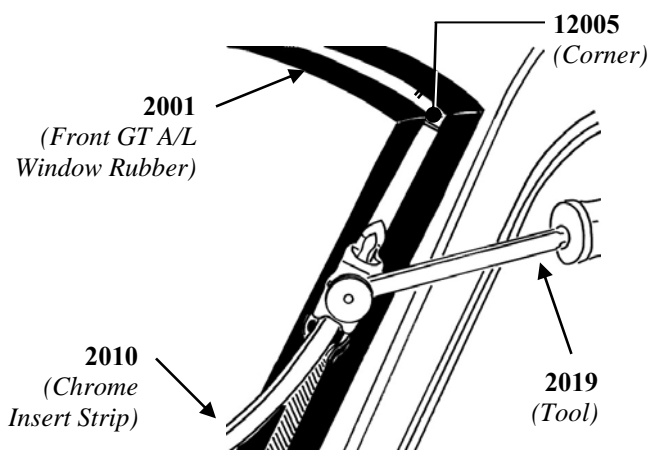

## Optional GT/J style (Explained)

Some European-only later Opel GT's were of the "GT/J" design, which blacked-out all window trim.

### GT/J Front, Rear & Side Trim

#### **2011 GT/J WINDOW CHANNEL, FRONT**

Front window rubber without a groove, that is solid rubber with no place for chrome. Gives your car a European "Cafe Racer" look! Reproduction item.

#### **2012 GT/J WINDOW CHANNEL, REAR**

Rear window rubber without a groove, that is solid rubber with no place for chrome. Gives your car a European "Cafe Racer" look! Best when used with 2011. Reproduction item.

#### **2013 GT/J QUARTER WINDOW CHANNEL, FIXED**

Quarter window rubber for 1968-1970 fixed quarter windows (non-opening), solid, with no place for chrome. Reproduction item.

*Exterior GT/J style rubbers were of a solid-rubber design.*

*Many Opel GT owners have converted their cars to this look, using our GT/J window trim and some custom paint work.*

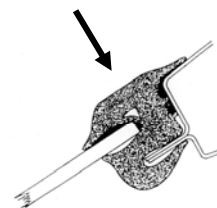

## Side Window "Fixed"

### 2003 GT A/L QUARTER WINDOW CHANNEL, FIXED STYLE

Quarter window rubber for 1968-1970 fixed quarter windows (non-opening), with groove for your chrome. Reproduction item.

### 2013 GT/J QUARTER WINDOW CHANNEL, FIXED STYLE

Quarter window rubber for 1968-1970 fixed quarter windows (non-opening), solid, with no place for chrome. Reproduction item. Best when used with GT/J style front rubber 2011 and GT/J rear 2012.

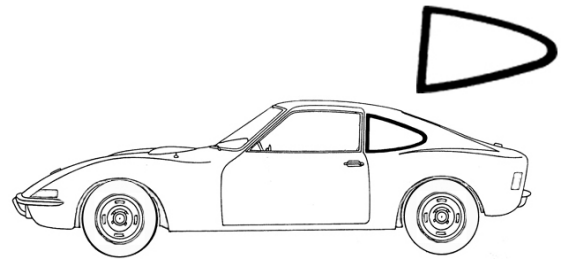

## "Fixed" Side Windows

*Original 1968-1970 Opel GT's had side quarter windows which were placed into a rubber moulding then simply pressed into the side of the body. OGTS also offers #2050S louvers to fit this glass.*

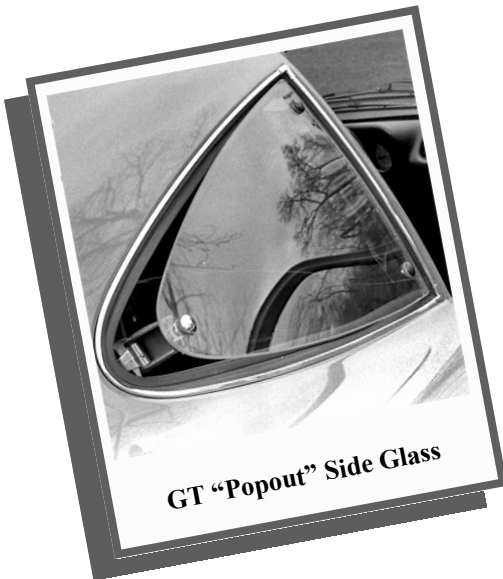
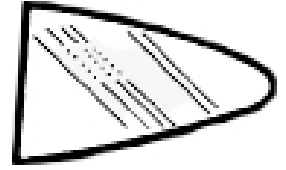

## "Popout" Side Windows

*Original 1971-1973 Opel GT's had side quarter windows which included front brackets and a rear hinge mechanism so they could be opened and closed.*

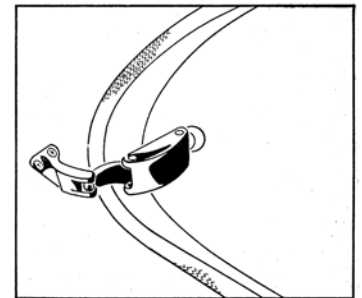

This greatly aids ventilation, which can be particularly helpful during warmer Summer road trips. Some owners of earlier GT's have also retrofit their vehicles to add this function.

In either case, we advise owners to consult our "tip" sheets prior to performing service on this style of window, to avoid damage to some critical components.



**2057**  
(Stainless Steel Buttons, Set of 3)

## Side Window "Popout"

### 2004 GT-A-L QUARTER WINDOW CHANNEL, POP-OUT STYLE

Quarter window rubber for 1971-1973 pop-out quarter windows, with place for chrome. Reproduction item.  
*Note: GT/J style is matchable w/black painted trim*

### 2018 GROMMET SET

Pop-out window plastic grommets which fit in between the window and hardware. Helps keep moisture outside. Set of twelve (12) for both windows.

### 2058 QUARTER WINDOW TRIM

Reproduction. Metal Trim around 1971-1973 "Popout" Side Window. Special Order Item.

### 2065 POPOUT HINGE REPAIR KIT

### 2055 BUTTON, STAINLESS STEEL, for REAR POP-OUT LATCH

Stainless Steel production of the rear latch button for the pop-out window of the 1971-1973 Opel GT. Fits Left or right sides.

### 2056 BUTTON, STAINLESS STEEL, for FRONT POP-OUT HINGE, PAIR

Stainless Steel production of the front hinges buttons for the pop-out window of the 1971-1973 Opel GT. Pair. Fits Left or right sides.

### 2057 BUTTON SET, STAINLESS STEEL, for ONE (1) POP-OUT WINDOW

Stainless Steel production of rear latch & hinge buttons. Includes: One (1) 2055 & Two (2) 2056 buttons, enough for one pop-out window. Fits Left or right sides, 1971-1973 GT.

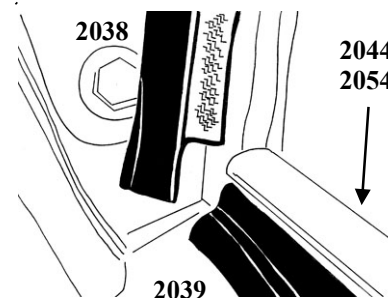
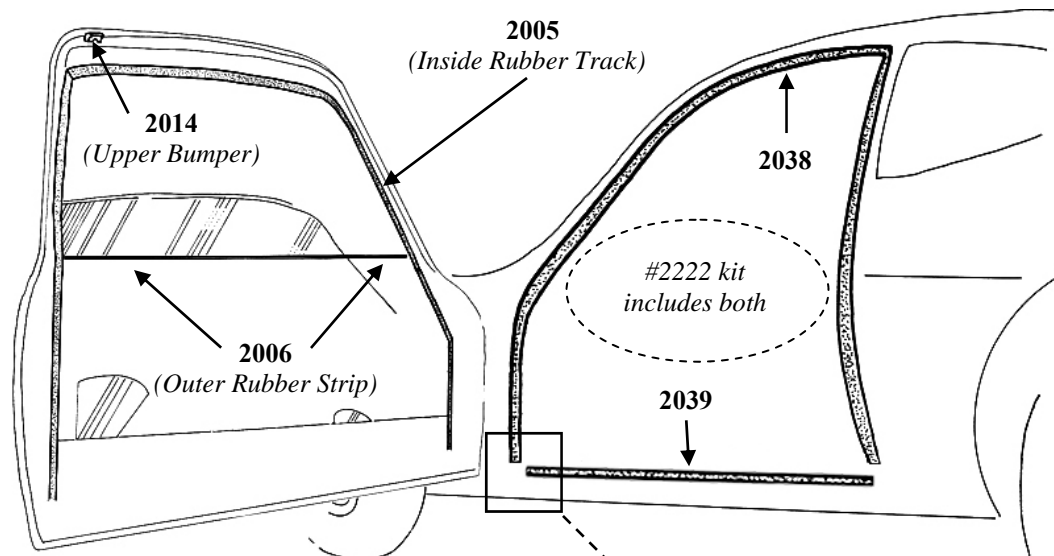

## Door Hardware & Seals

### 2005 DOOR WINDOW TRACK

This rubber channel has a center groove that the door glass slides up and down in, and an exterior lip that holds the chrome trim in place. One set does 2 doors.

### 2005A DOOR WINDOW TRACK

Same as 2005, but does one door.

### 2036 WINDOW TRACK CLIP, set of 20

These clips are used to fasten the door window track rubber 2005 to the GT window channel.

### 2006 LOWER DOOR WINDOW RUBBER SCRAPER

Outside scraper which contacts the lower part of the door window to keep dirt and water out.

### 2014 UPPER DOOR BUMPER

Rubber stop which protects car body when door closes. Also helps stop door rattles. A required part for repaint projects. Fits both right or left, 2 required per car.

### 2064 DOOR JAMB SWITCH

### 2222 DOOR WEATHERSTRIPPING

This is an important seal that helps keep water from entering interior (causing damp carpets and rusted floorboards). We offer a top-quality reinforced custom-fit design with attractive grain backing that is sturdy to provide superior sealing and durability (compared to more 'generic' styles). You can have savings here too, with this 24-foot uncut DIY reproduction, enough for both doors upper and lower.

### 2038 DOOR WEATHERSTRIPPING, UPPER

Rubber for sealing the door to the body. Keeps dirt, wind and water out of your interior. Right or left, two (2) required per car. Available in black, white or tan. Aftermarket.

### 2039 DOOR WEATHERSTRIPPING, LOWER

Rubber for sealing the door to the body. Keeps dirt, wind and water out of your interior. Fits under door kick panel to seal lower part of door. Right or left, two (2) required per car. Available in black, white or tan. Aftermarket.

### 2044 TRIM SCREW

Trim screw for GT door sill plate.

### 2054 GT DOOR SILL

European reproduction of the Opel GT door sill. Made of polished stainless steel. Best when purchased in a matching pair of left & right.

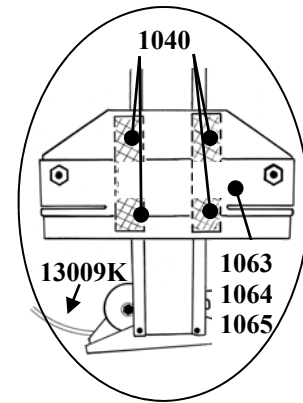
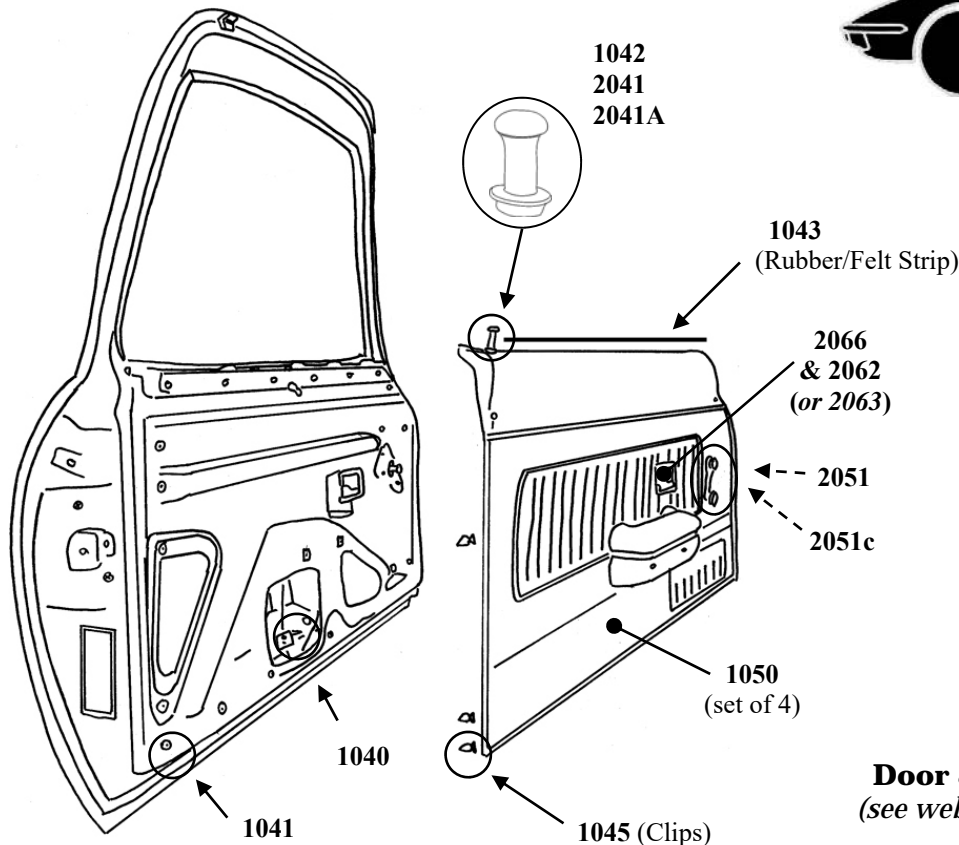
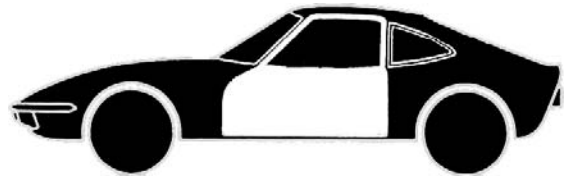

**Door & Window Glass hardware**  
 (see website at: [www.opelgtsource.com](http://www.opelgtsource.com)  
 for additional views)

**Door Hardware, Internal**

**1040 NYLON GLIDES, for GT DOOR GLASS LIFTER**  
 These nylon glides fit in your GT's door glass lifter. Helps smooth window operation, extends life of window regulator gears and cables. Set of four (4) glides and two (2) rivets., will repair one (1) door lifter.

**1041 GROMMET, DOOR PANEL PLUGS, set of 10**  
 These help to secure the door panel clips into the door sheet metal. One set required per GT door.

**1042 KNOB, ALUMINUM DOOR LOCK BUTTON**  
 Dress up your Opel's interior with this pair of polished aluminum door lock buttons. Best w/#2041 rings.

**1043 INNER DOOR WEATHERSTRIP**  
 All-new reproduction of this critical interior strip. Solid rubber backing with a flocked edge, this strip clips onto the upper edge of the interior door panel and helps quiet the interior and secure the door glass from vibrations. Easy installation w/ our instructions

**1045 DOOR PANEL CLIP, set of 10**  
 Reproduction clips for all your interior upholstery panels, secures door, kick & quarter panels to frames.

**1050 GT DOOR PANEL SET of 4, BLACK**  
 Opel GT Door Panel & Quarter Upholstery panel set. Set of 4 pieces Note: Your old front left & right GT door panel metal tops must be returned to Opel GT Source.

**1063 DOOR GLASS ROUND MOUNT RINGS**  
 Nylon rings installs glass on 1971-1973 GT's

**1064 DOOR GLASS ROUND MOUNT RINGS**  
 Metal bar installs glass on 1968-1970 GT's

**2041 DOOR LOCK RING**  
 Tops off your door panels. Plastic.

**2041A DOOR LOCK RING, ALUMINUM**  
 Polished Aluminum, best installed with #1042 knobs

**2051 WINDOW CRANK HANDLE**  
 New reproduction of critical-wear item, includes C-clip

**2051C CLIP, for WINDOW CRANK HANDLE**  
 Clips retains the window crank handle to the shaft

**2062 BEZEL FRAME + INSERT for ONE DOOR**  
 Metal Rectangular Frame and insert around door pull

**2063 DOOR BEZEL, PLASTIC BACKING INSERT**  
 Black plastic piece, inserts into frame behind door pull

**2066 DOOR LATCH HANDLE, INTERIOR**  
 Helps complete interior restoration. Select L or R side.

**13009K GT WINDOW REGULATOR RECABLE KIT**  
 Replacement cable plus retainer ferrels. Your core unit must have intact, functioning gears



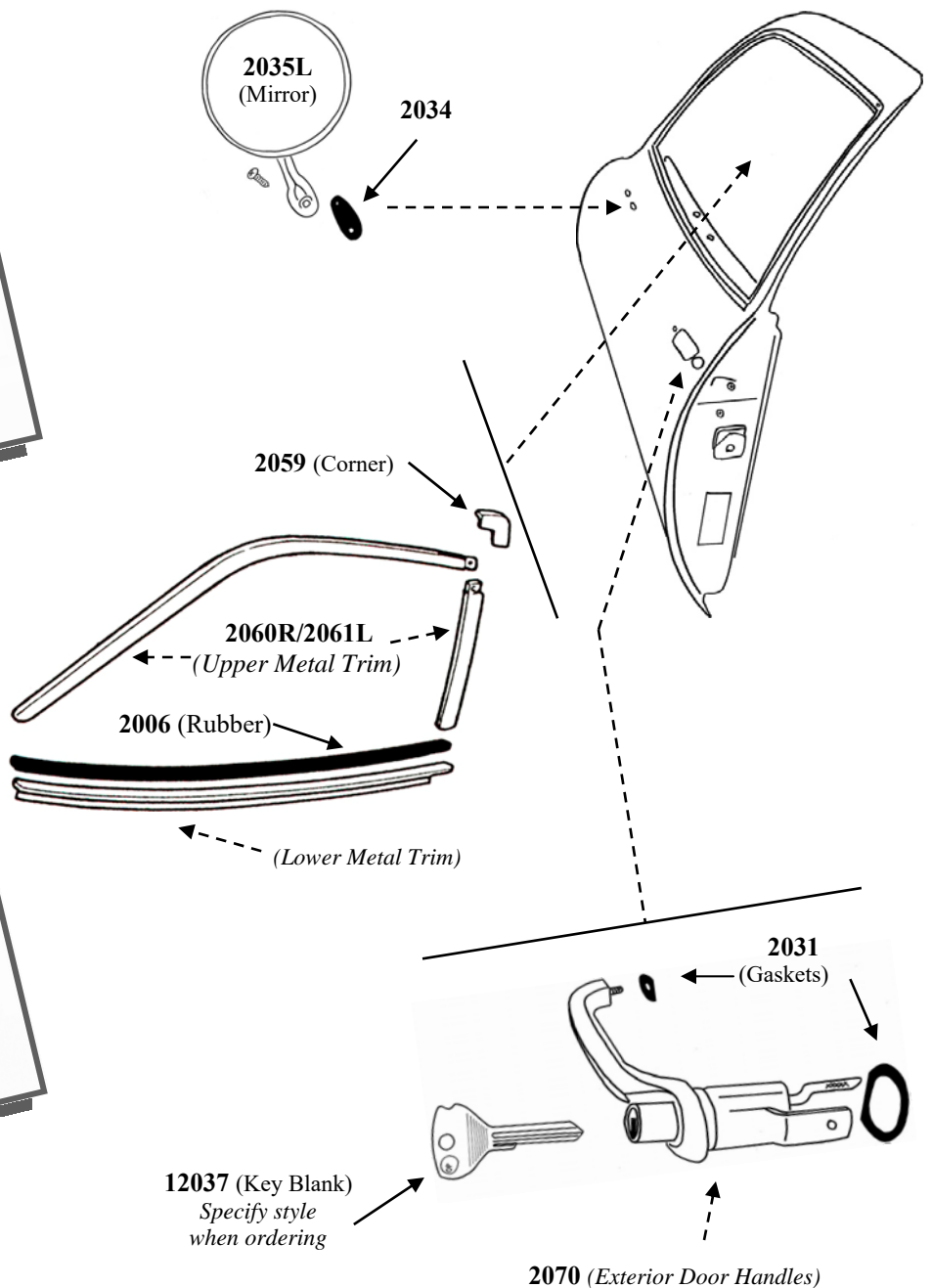
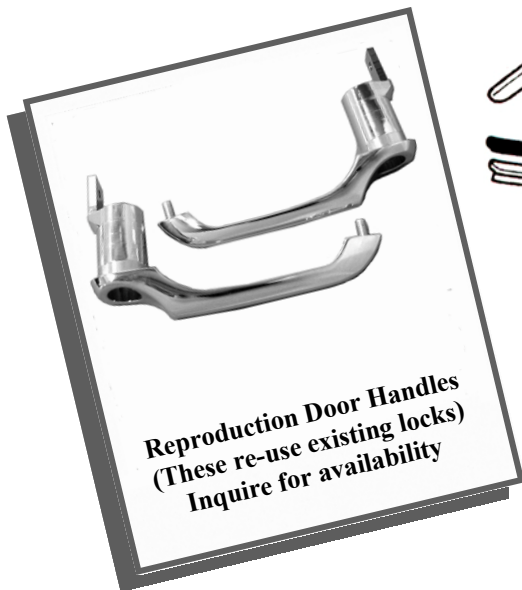

## Door Hardware, External

### 2031 DOOR HANDLE GASKETS

Rubber, set of four (4) per GT. Ideal for paint projects

### 2034 DOOR MIRROR GASKET

Reproduction, gasket for original Opel GT chrome mirrors. Left or right.

### 2035L DOOR MIRROR, DRIVERS SIDE

Reproduction, original style Opel GT chrome mirror

### 2035R DOOR MIRROR, PASSENGER SIDE

Same as 2035L, fits passenger side door.

### 2060R/2061L UPPER DOOR METAL TRIM

Select right, left, or both doors. Includes vertical metal and curved horizontal metal trim piece. Special Order.

### 2070 OPEL GT DOOR HANDLE

New Reproduction Door Handles, Exterior. Sold as a Pair. Import item.

*These allow you to re-use your existing lock/key*

### 12025 SPORT MIRRORS, BLACK

Reproduction of the classic 'Sport' mirror used on many Opels. Fits left or right. Buy two (2) for your project.

### 12037 KEY BLANK

Two types in stock. Specify type 12037A or 12037B when ordering: Request from styles (shown in accessories section, or print-version Part List guide)





**Fiberglass is your affordable body panel solution**

**As a cost-effective alternative to locating original-design metal panels, Opel GT Source has reproduced these hard-to-find panels in rust-proof and affordable fiberglass,**

*These are lightweight yet sturdy, and are commonly accepted for shipment via UPS (United Parcel Service) to locations within North America.*

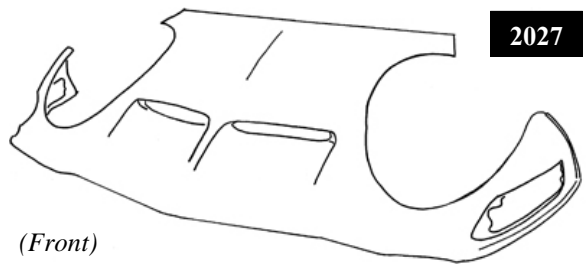

**2027**

(Front)

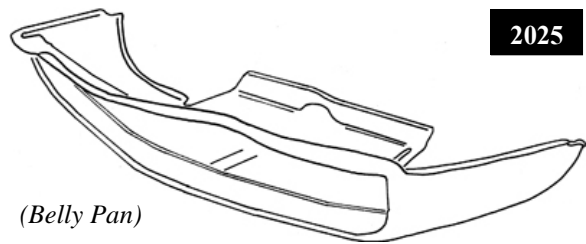

**2025**

(Belly Pan)

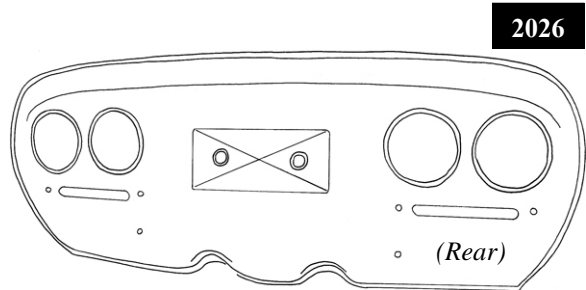

**2026**

(Rear)

**Body Panels, Fiberglass**

**2025 FIBERGLASS BELLY PAN**

A fine reproduction of the original belly pan. Made of high-quality "hand-layed" fiberglass. Rust and battery acid safe. Less likely to be dented than a steel belly pan. Can be bonded or riveted to body to install. Oversized shipping.

**2026 FIBERGLASS REAR PANEL**

A fine reproduction of the original rear panel. Made of high-quality "hand-layed" fiberglass. Helps repair accident damage to rear body. Body work required to install. Oversized shipping.

**2027 FIBERGLASS NOSE PANEL**

A fine reproduction of the original nose panel. Incorporates the front curved front corners. Made of high-quality "hand-layed" fiberglass. Often used as a collision repair part, Body work required to install. Oversized shipping.

**Body Panels, Metal**

**2050 REAR WINDOW LOUVERS, GT**

High quality metal rear window louvers. Special design allows for good rear visibility, while deflecting sunlight to lower interior temperatures. Powder coated black for durability and easy to install.

**2050-S SIDE WINDOW LOUVERS, GT**

Fits GT's using fixed-quarter style side windows. Set of 2, gives your car an "old school classic" look! Best when used with #2050. New reproduction item.

**2067 OPEL GT FLOOR PANS**

Special imported reproduction. See website for details.

**2068 OPEL GT OUTER ROCKER PANEL**

Special imported reproduction. See website for details.

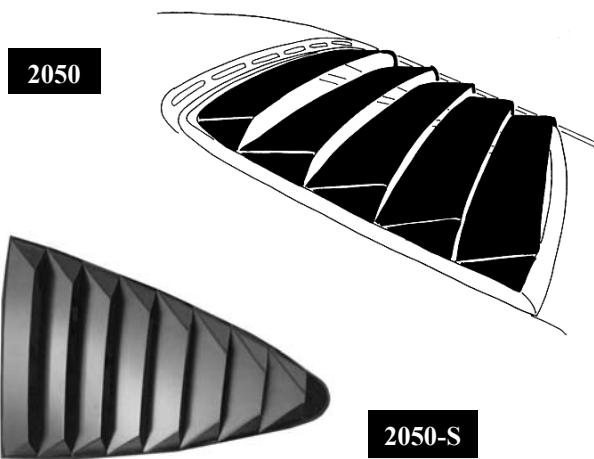

**2050**

**2050-S**

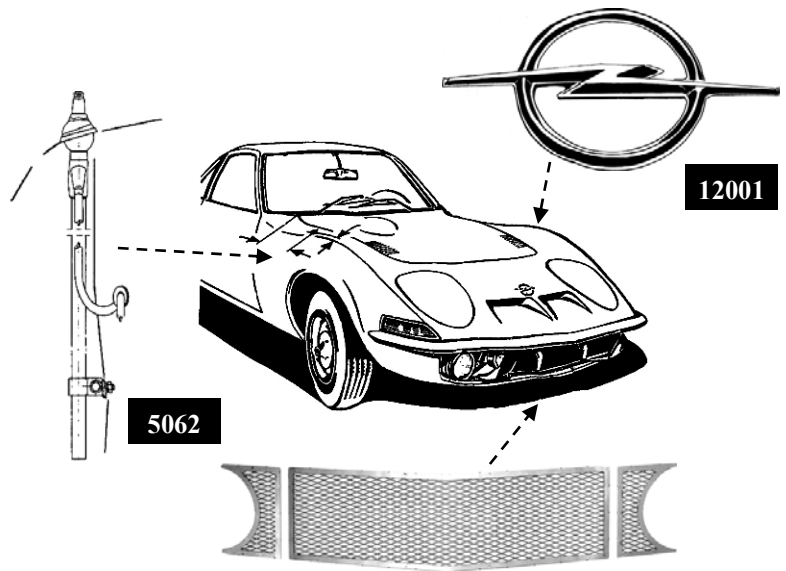
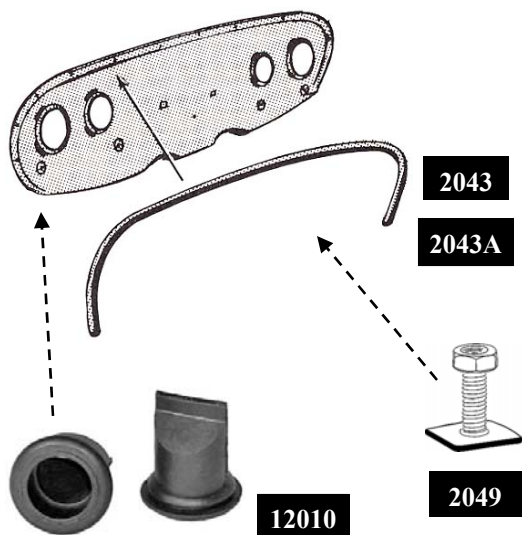

*Shown: Stainless Steel Set #2046SS*

**GT Body Trim & Hardware**

**2042 BUSHINGS**  
GT hood latch pivots. Replace your worn or missing hood latch bushings with new nylon. Set of two (2).

**2043 GT REAR TRIM MOULDING**  
Choose: Chromed or Black plastic. Adhesive-backed.

**2043A GT REAR TRIM MOULDING**  
Reproduction in Metal. Installs with #2049 Studs. Special Order Item.

**2043B GT REAR TRIM**  
Rear trim in Black

**2045 GT CENTER GRILL**  
German reproduction of the GT center grill. Painted in satin black.

**2046 GT SIDE GRILL**  
GT side grill. German reproduction. Available for Left or Right side. Painted satin black.

**2046SS GT GRILL SET, STAINLESS STEEL**  
GT front & side grilles that will not rust! Can also be painted black if desired.

**2049 MOUNTING STUDS, for REAR TAIL LAMP PANEL TRIM STRIP**  
Set of ten (10) new studs. Replaces rusted, stripped or missing original studs. Allows you to mount the stock trim strip to the back of your Opel GT.

**2069 OPEL GT WIPER ARMS**  
Reproduction in Metal. Imported item. Sold as a pair.

**5062 GT/MANTA ANTENNA**  
Antenna for your Opel GT or Manta. OEM German antenna.

**12001 BLITZ EMBLEM, OPEL GT FRONT**  
Chrome front emblem used on all Opel GTs from 1968 thru 1973. Chromed Plastic. Available Again!

**12010 DRAIN BOOTS**  
Rear underbody. Seals the water drain tubes that exit the GT rear floor pan and helps prevents fumes from entering. Sold individually. Two (2) required per GT

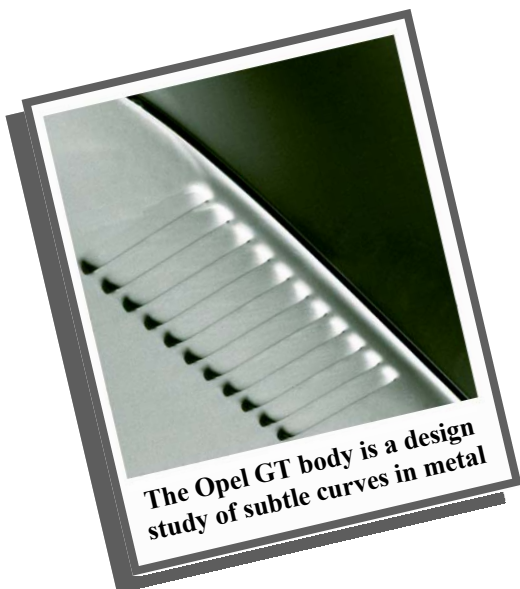

*The Opel GT body is a design study of subtle curves in metal*

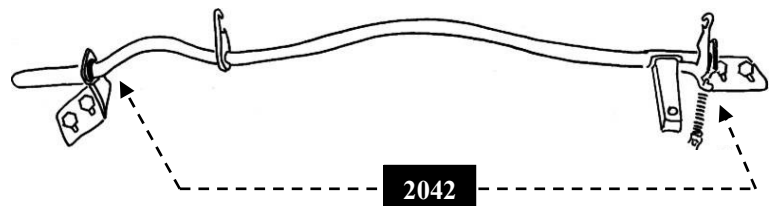

*You can also view additional exterior hardware, such as original style body emblems, in the "Accessories" section (parts numbered #12000)*

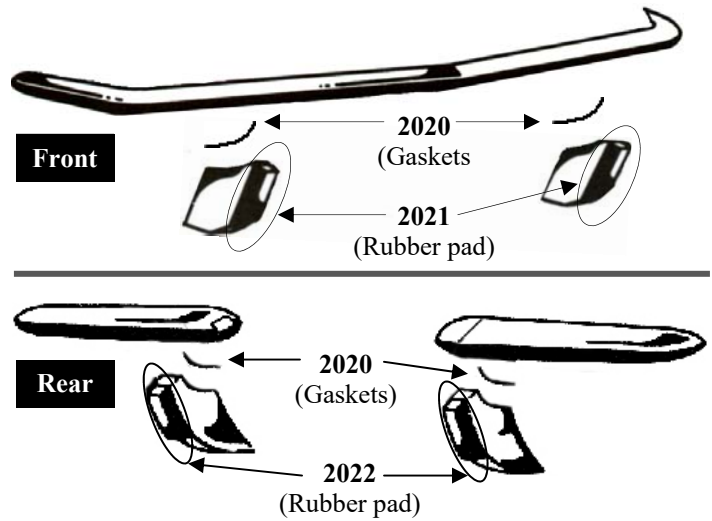
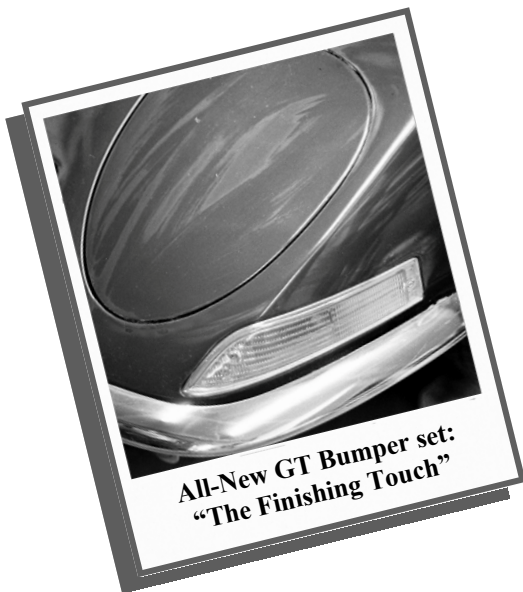

**Front**

*“Gorgeous” and “Far Superior”  
(to re-chroming) are comments made by buyers.*

**All NEW Stainless Steel Bumper Set**  
**Ideal for show-winner Opel GT’s**  
**and the ‘finishing touch’ for all other restorations.**  
 Made by the industry-leading producer,  
 these feature a high-chrome content that will not rust.  
 Includes front and rear bumpers, plus bumperettes.  
 Additional parts are available from us, such as lens caps,  
 and rear bumper spacers, to complete your installation.  
*With Opel GT Source, your purchase and shipment can  
 stay domestic within North America (via UPS Ground),  
 with no import duties or foreign payments required.*



**Rear**



**SSGT (Set)**

**GT Bumpers & Hardware**  
**SSGT GT STAINLESS STEEL BUMPERS**  
 Here at last, Stainless Steel Opel GT bumper set  
 for the 1968-1973 Opel GT.  
 Our Set includes: Front Bumper,  
 Left & Right Front Bumperette with rubber pad,  
 Rear Bumpers (left & right),  
 Left & Right Rear Bumperette with rubber pad.  
 Plus we include the bumper to bumperette gaskets.

**2020 BUMPER GASKET SET**  
 Fits between the bumper and bumperette,  
 set of four (4).

**2021 BUMPERETTE RUBBER, FRONT**  
 Replica of original front bumperette rubber.

**2022 BUMPERETTE RUBBER, REAR**  
 Replica of original rear bumperette rubber.

**2048 REAR BUMPER SPACER & SLEEVE**  
 New bumper spacers with sleeves. Want that  
 finishing touch for your GT’s body & rear bumpers?  
 Then these reproduction spacers & sleeves are for you.  
 Six (6) pieces required per GT.

## Body Notes

You can choose to restore your Opel GT to its original condition and color, or you can modify your Opel GT with a more modern color, or complement it with aftermarket parts and accessories).

When planning a paint job, we suggest purchasing all necessary parts before you start, so that you or your shop can proceed at a pace that is best for your car— which is especially important if you have a deadline planned.

### Paint

We suggest starting with our “paint project notes” which has discussions regarding color choices, trim options (GT A/L vs GT/J), notes about combining headliner and heater service, and additional suggestions such as using diagrams to assist communication with your paint/body shop. (See the “tips” section of our website at: [www.opelgtsource.com](http://www.opelgtsource.com)).

### Windshield

In order to protect this vulnerable curved glass panel, we advise cutting the rubber moulding surrounding it, then lifting out the glass, as a removal procedure. Trying to pry the glass from the rubber, will break it! Replacement options include new, new old stock, or good used glass. Pilkington Classics of Ohio offers new replacement windshields for the GT; Their toll-free phone is at 800-848-1351.

### Floor Pan

Feedback from Opel owners has indicated that a popular money-saving approach to floor pan replacement, is to acquire panels produced for the 1964-1966 Ford Mustang and trimming the edges to fit the GT. (Goodmark Industries, Sherman Parts and others offer these).

### Fiberglass Panel Replacement

For best results, make sure replacement fiberglass panels are warm prior to assembly. Working in a warm area also helps to ensure optimum fiberglass fitment.

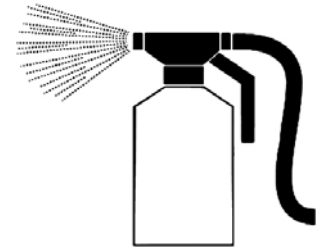
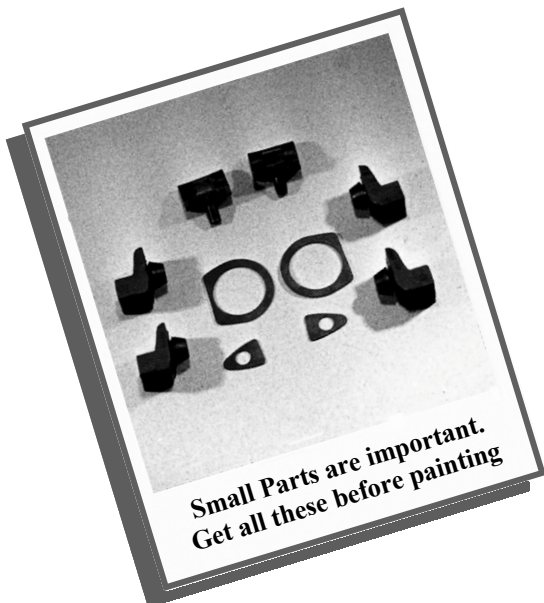

*Read our online notes,  
before starting your  
paint project*



*Handle Glass with care!*



*The “Mustang solution”  
See our notes online*





**2048 GT Rear Bumper Spacers**  
Nice Reproduction  
*Inner Metal plus Outer Rubber Sleeves*



**2035L Door Mirror**  
All New Glass and Metal Housing  
*Nice upgrade, easy installation*



**2026 GT Taillight Panel**  
All New Fiberglass  
*Replacement for damaged rear panel*



**Used Body Parts also available**  
Contact Opel GT Source with your needs  
[opelgts@opelgtsource.com](mailto:opelgts@opelgtsource.com)



**2222 GT Body Weatherstrip**  
High-Grade, Seals body at door openings  
*Black. Install notes available*



**2024 GT Headlight Gasket**  
Reproduction item.  
*Fits under headlight bucket lid*



**2033 GT Headlight Cable**  
Replacement, Reproduction  
*Replace your worn or stuck cable*



**2014 Door Top Bumpers**  
Quality Reproduction  
*Helps keep body paint intact at door tops*



**2062**



**2063**



**2066**

**2062 Door Pull Bezel w/Frame**  
New metal and plastic, select L or R

**2063 Door Pull Bezel Insert**  
Plastic backing only, select L or R

**2066 Door Pull (Interior)**  
All new reproduction item. Select L or R  
*Looks and works great!*



**2051 GT Window Crank Handle**  
Our New Reproduction , includes C-clip  
*Replace yours for precise crank function*



Rear & Side Window Louvers

**2050 & 2050S Window Louvers**  
*Upgrade to this "classic look" on an Opel GT (fits fixed side glass)*



**3000/Suspension**





Nowadays 21st-century cars separate the driver from the machine, as traction control and automatic stability settings cause road feel to be lost. Somewhere in the modernization process (as noted by the hosts of "Top Gear"):  
*"We forgot how good these cars could be. Just joy. Just handling...."*

Drivers of upgraded GT's attest to an unfiltered excitement of live-axle steering, where the chassis grabs and bites on hard accelerations through curves on the road. *Getting that response from your GT, can be accomplished with a few simple projects!*

The GT was originally designed for a great handling capability by Opel. However, GM's HQ in Detroit presumed the US owner wanted a "soft" ride and softened the spring rates and deleted the sway bars. Since then, auto journalists and GT owners noted wheel lift and "excessive" body roll while enjoying their favorite back-roads.

*Opel GT Source offers performance sway bars, shocks, springs and polyurethane bushings that will restore your GT's handling for a surer more positive road feel.*

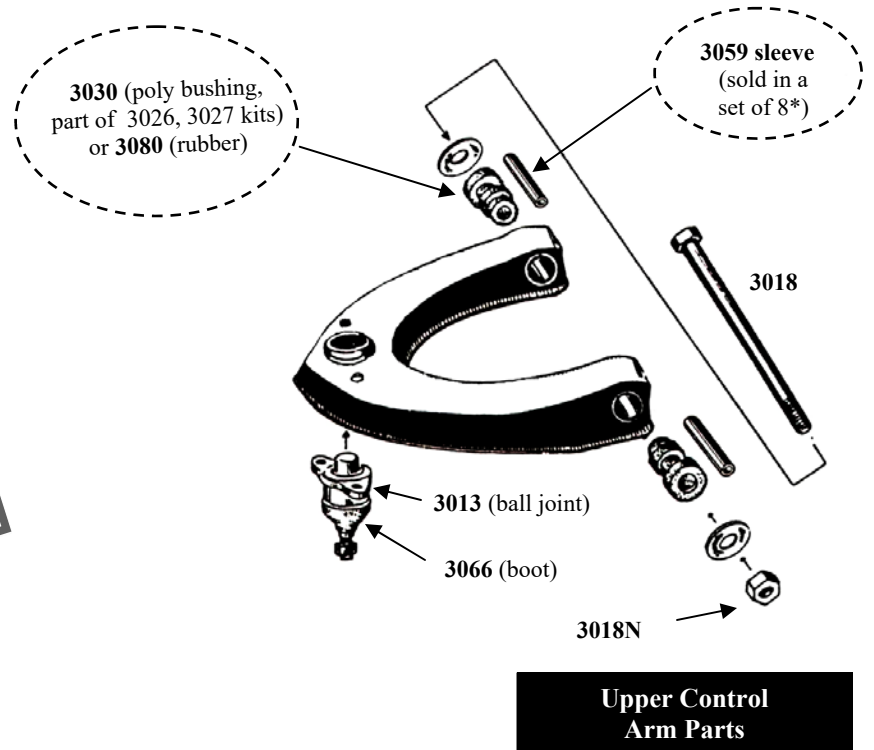

### Upper Control Arm

#### 3013 UPPER BALL JOINT

Located on front suspension upper A-arm.

#### 3018 BOLT, UPPER CONTROL ARM

Replace your rusted or jammed upper control arm bolt with this brand new unit. Also do not forget to order a new nut, 3018N.

#### 3018N NUT, for UPPER CONTROL ARM

Brand new nut for the upper control arm bolt. Best when used w/a new upper control arm bolt, 3018.

#### 3018S SHIM KIT, UPPER CONTROL ARM

#### 3030 1969-1973 UPPER CONTROL ARM BUSHING, SOFT

Soft compound polyurethane. Upgrades steering by reducing your turn radius. Select red or black.

### Upper Control Arm Parts

#### 3059 INNER SLEEVES, METAL

For polyurethane upper and lower control arm bushings or kits #3026/3027 or #3028/3029. Set of eight (8). Specify year/model application or lower arm bushing size (.710" or .745" O.D.) when ordering.

#### 3066 DUST BOOT, UPPER OR LOWER BALL JOINT

Why replace a good ball joint if all you need is a new boot? Polyurethane, four (4) required per car.

#### 3080 UPPER CONTROL ARM BUSHING, RUBBER

Upper control arm bushing with inner and outer sleeves attached. Perfect for show room stock restorations. 4 per suspension, or see #3082 kit.

#### 3093 UPPER CONTROL ARM GROMMET

Rubber washer adds support during hard braking



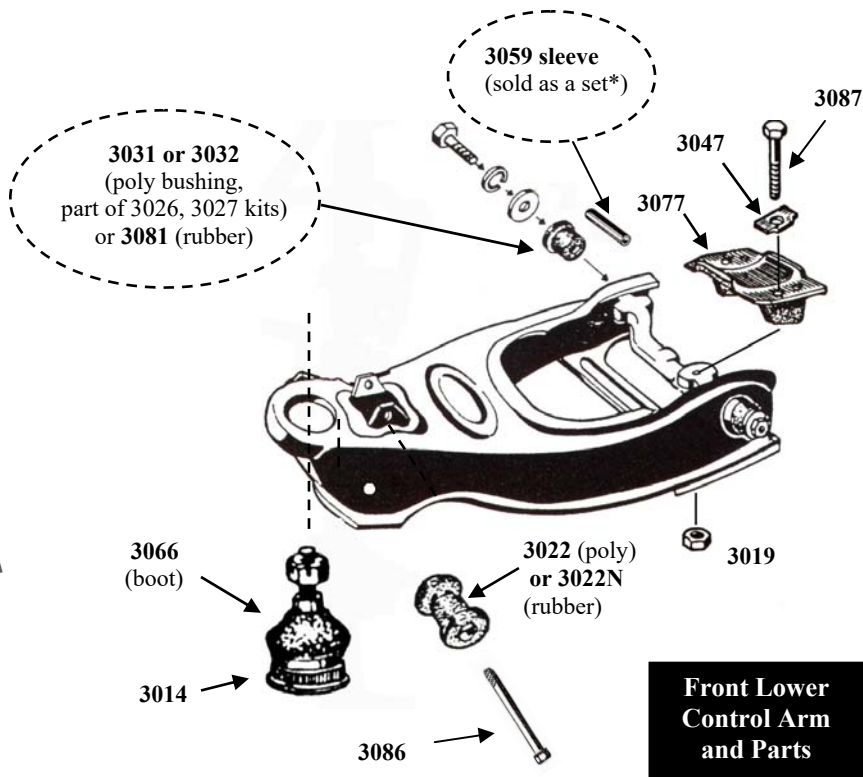
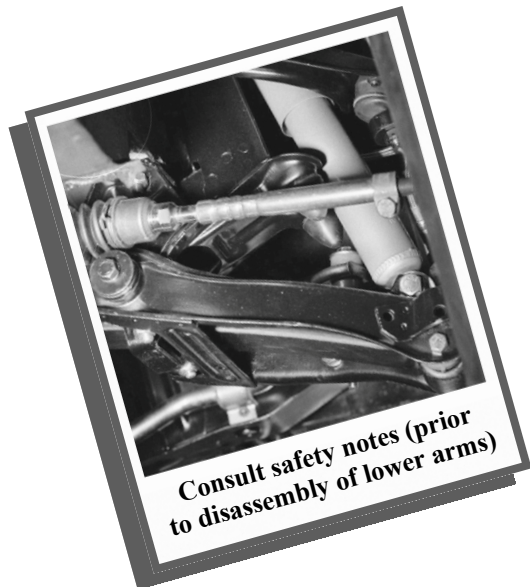

## Lower Control Arm

### 3014 LOWER BALL JOINT

Located on front suspension lower A-arm.

### 3019 LOCK NUT, LOWER ARM BOLT

Should be replaced each time you remove the lower control arm. Four (4) required per front end.

### 3022 SPRING EYE BUSHINGS

Polyurethane. Located on both ends of the original front leaf spring. Easy to install, no special tools required. Set of two (2).

### 3022N SPRING EYE BUSHING, RUBBER

Rubber. Located at either end of the original front leaf spring. Two (2) rubber bushings are required.

### 3031 1969-1971 LOWER CONTROL ARM BUSHING, SOFT

Soft compound polyurethane. Inner diameter .710".

### 3032 1972-1973 LOWER CONTROL ARM BUSHING, SOFT

Soft compound polyurethane. Inner diameter .745"

### 3047 WASHER

Lower Control Arm to Suspension Cross Member

### 3059 INNER SLEEVES, METAL

For polyurethane upper and lower control arm bushings or kits #3026/3027 or #3028/3029. Set of eight (8). Specify year/model application or lower arm bushing size (.710" or .745" O.D.) when ordering.

### 3066 DUST BOOT, UPPER OR LOWER BALL JOINT

Why replace a good ball joint if all you need is a new boot? Also promotes joint longevity and helps prevent premature failure. Polyurethane, four (4) req. per car.

### 3077 FRONT LEAF SPRING SADDLE / PERCH

Front spring support plate. This piece sandwiches between the lower control arm and the front suspension cross member. Fits all year GT. Two (2) required per car.

### 3081 LOWER CONTROL ARM BUSHING, RUBBER

Lower control arm bushing with inner and outer sleeves attached. Perfect for all-stock restorations.

### 3086 BOLT, SPRING EYE to LOWER CONTROL ARM

Brand new bolt to replace those old rusted bolts. Often these bolts are rusted into the spring eye bushing and need to be cut off. Two (2) Bolts per front leaf spring. Note: Does not come with nut.

### 3087 BOLT, LOWER CONTROL ARM to CROSS MEMBER

Brand new bolt to replace those old rusted bolts. Often these bolts are rusted into lower control arm bushing knuckle and need to be cut off. Two (2) Bolts per arm.

### 3091 LOCK NUT, FRONT LOWER SHOCK

Brand new lock nut to replace your rusted or worn originals. 1x lock nut required per shock mounting.

### OUTER METAL SLEEVE, LOWER CONTROL ARM

New replacement part for altered arm. Special order.

## Front Suspension Bushings

A required maintenance item on a classic Opel GT is replacement of the original and often dried-out rubber suspension bushings.

For durability and optimal ride quality, including improved steering response and reduction of a "55 mph shimmy," we recommend polyurethane bushing sets from Opel GT Source. *Productions are made in red or black colors*



### Front polyurethane bushing sets

Select #3026  
or #3027

## **Poly Front Suspension Bushings**

### **3026 1969-1971 CONTROL ARM BUSHING SET, SOFT**

Soft compound replacement polyurethane bushings. Set of eight (8). For upper and lower control arms. Street and sport application. Easy to install, no specialized tools required. Complete with teflon grease and instructions. Select red or black color.

### **3027 1972-1973 CONTROL ARM BUSHING SET, SOFT**

Soft compound replacement polyurethane bushings. Set of eight (8). For upper and lower control arms. Street and sport application. Easy to install, no specialized tools required. Complete with teflon grease and instructions. Select red or black color.

### Inner Sleeve sets

Available replacements for optional function.

Specify diameter



### **3059 INNER SLEEVES, METAL**

For polyurethane upper and lower control arm bushings 3027 or 3029. Set of eight (8). Specify year/model application or dimension: 0.710" or 0.745" Outer diameter

### **3061 TEFLON GREASE**

Waterproof. Lubricates polyurethane to quiet squeaking. Individually packaged.

## Poly Bushing Notes

Opel GT Front Lower Arms require measurement for proper bushing installation.

*Use a caliper or a 18mm wrench, to verify whether you have a .710" or a .745" diameter inner sleeve.*

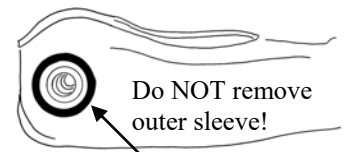
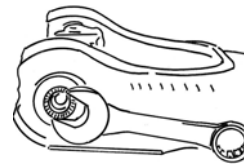
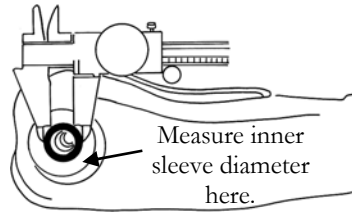

*Poly bushings re-use your existing outer sleeves*



## **Rubber Bushings**

### **3082 CONTROL ARM BUSHING SET, RUBBER**

Upper and lower control arm bushing set with inner and outer sleeves attached. Set of eight (8). Perfect for show room stock restorations. Fits GT

### **3022N SPRING EYE BUSHING, RUBBER**

Rubber. Located at either end of the original front leaf spring. Two (2) rubber bushings are required.

### **7017 BUSHING KIT FOR REAR TRAILING ARMS**

Contains two (2) front and two (2) rear. Original rubber bushings.

### **7023 PANHARD ROD BUSHINGS, RUBBER**

Original rubber bushings for the rear panhard rod. Set of two (2).



## Steering Parts

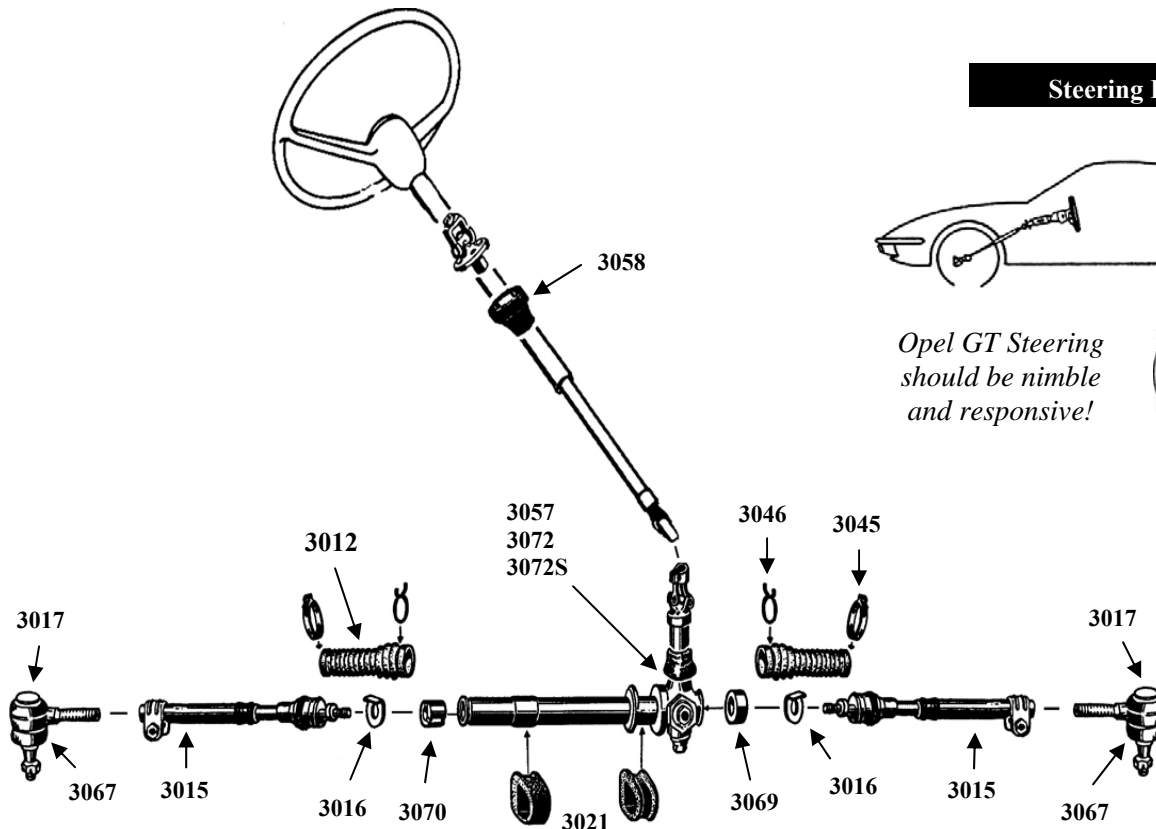

*Opel GT Steering  
should be nimble  
and responsive!*

### Steering Rack Hardware

#### 3012 RACK AND PINION BOOT

Keeps harmful dirt, moisture, road debris and sand from causing premature failure of your rack and pinion and inner tie rod end. Rubber reproduction.

#### 3015 INNER TIE ROD

Connects rack and pinion to outer tie rod  
Note: Very Early 1969 GT may require size verification

#### 3016 LOCKWASHER

Required to secure inner tie rod to steering rack

#### 3017 OUTER TIE ROD

Connects inner tie rod to front wheel steering knuckle.

#### 3021 RACK BUSHINGS

Polyurethane. Easy to install replacement bushings. Cushions and secures rack & pinion to cross member frame, is durable where you want it to be. Set of two (2).

#### 3045 INNER CLAMP, for RACK & PINION BOOT

Inner Clamp, Wider. Fits: All year GT

#### 3046 OUTER CLAMP, for RACK & PINION BOOT

Outer Clamp, Narrower. Fits: All year GT

#### 3057 DUST BOOT SEAL, PINION SHAFT

Seals pinion shaft to rack housing, rubber.

#### 3058 DUST BOOT SEAL, STEERING SHAFT

Steering shaft to firewall, rubber.

#### 3067 DUST BOOT, OUTER TIE ROD

Why replace a good outer tie rod if all you need is a new boot? Polyurethane, two (2) required per car.

#### 3069 RACK METAL BUSHING, LEFT HAND SIDE

Metal rack and pinion bushing. Required to repair sloppy rack. Common wear item. One (1) required.

#### 3070 RACK METAL BUSHING, RIGHT HAND SIDE

Sintered iron metal rack and pinion bushing. Required to repair sloppy rack. Common wear item. One (1) required. Fits GT.

#### 3072 BEARING, PINION SHAFT, RACK & PINION

This bearing is located in the top of the rack which the input shaft rides in. Don't forget protect your new bearing with a new Pinion Input Boot 3057 to seal all your hard work from the elements. Fits GT

#### 3072S SEAL, PINION INPUT, RACK & PINION

#### 3094 ELECTRIC POWER STEERING CONVERSION

The ultimate GT steering upgrade. Best for top-of-the-line street drivers, and also some V6/V8 conversions.

### Specifications: Opel GT Alignment

Caster: 3 degrees (+/- 1 degree)  
Toe-In Max: 1/32" - 1/8"

Camber: 1 degree (+/- 1/2 degree)  
Outer Wheel (when inner wheel is at 20 degrees): 18 1/2 degrees

## Front Suspension Hardware

### 3020 BUMP STOP BUSHINGS

Cushions impact of lower control arm into the frame during extreme driving conditions. Four (4) required.

### 3038 WHEEL BEARING, FRONT INNER

### 3039 WHEEL BEARING, FRONT OUTER

### 3040 SEAL, FRONT WHEEL BEARING

Cover to protect your wheel bearing from dust and dirt

### 3071 DUST CAP COVER

Dust cap cover for front wheel bearing.

### 3048 UPPER FRONT SHOCK MOUNT

Replaces rusted GT front upper shock support. One per shock tower. Welds into place.

### 3075 GASKET, BODY to UPPER CUP

This gasket is located between the upper suspension locating-cup and the inner fender. Two (2) required per car.

### 3076 BUSHING, UPPER SUSP to BODY CUP

These bushings fit in the cups that locate the upper suspension cross member to the inner fender. Two (2) required per car.

### 3085 FIBER SPACER, FRONT AXLE to FRAME

This spacer is located between the front suspension cross member and the chassis. Often these spacers are cracked or crushed. Two (2) required. For GT.

### 3092 SHOCK TOWER COVER, ALUMINUM

Round cap, approx 2 1/2" diameter

### 3095 CONTROL ARM GUSSET SET, STEINMETZ

Weld-on support plates for GT arms, reduces arm flex

### 3096 SHOCK TOWER COVER, PLASTIC

Round cap in clear, approx 2 1/2" diameter

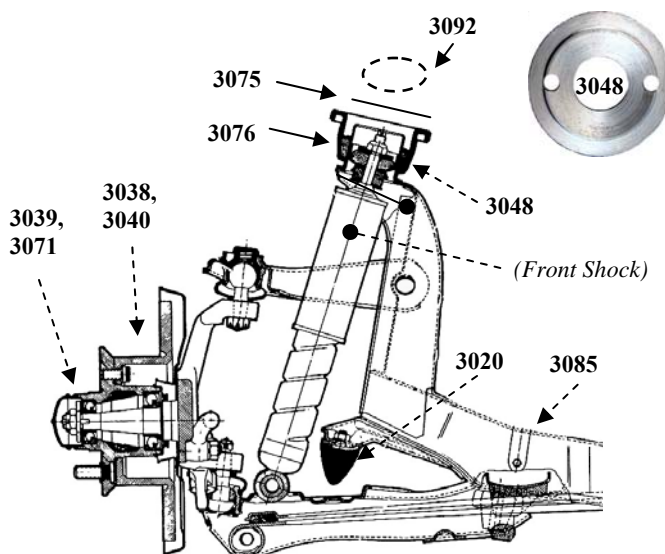

## Front Suspension Hardware

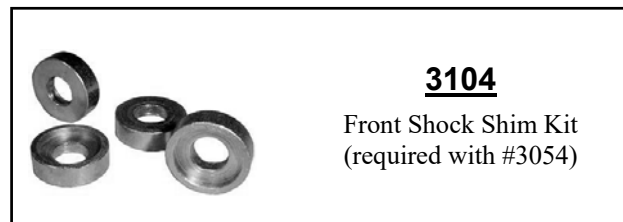

### 3104

Front Shock Shim Kit  
(required with #3054)

## Front Shocks & Hardware

### 3054 LOW PRESSURE GAS FRONT SHOCK

GT. Great for street and winding roads. Requires installation kit #3104 to install on a GT.

### 3104 INSTALLATION KIT, for 3054

Shim Kit to install the #3054 Front Shocks into a GT.

### 3007 KONI RED FRONT SHOCKS

The ultimate handling upgrade for a performance-driven GT. Good for street and sport applications. Fully adjustable. Best when used in conjunction with 3008 Red Rear Shocks.

### 3048 UPPER FRONT SHOCK MOUNT

Replaces rusted front upper shock support. One per shock tower. Fits GT. Welds into place.

### 3090 BOLT, FRONT LOWER SHOCK MOUNTING

Brand new bolt to replace those old rusted bolts. Often these bolts are rusted or incorrect from a previous repair. One (1) bolts per front lower shock absorber mounting. Fits GT.

### 3091 NUT, FRONT LOWER SHOCK MOUNTING

Brand new lock nut to replace your rusted or worn originals. 1x lock nut required per shock mounting.



3001



**Sport Springs**

3062



3023



**Lowering Spring**

**Front Sport Springs & Hardware**

**3062 SPORT LEAF SPRING, STREET**

Lowers car 1". Improves overall appearance and handling of your GT without sacrificing ride quality. Perfect for hot street or autocross applications. Also helps direct airflow under car. Usable with stock or performance rear springs. Installs with performance polyurethane bushings (3023). Installation Instructions included.

**3023 SPRING EYE BUSHINGS**

Polyurethane. Specially made for sport front leaf springs #3062 or #3001. Easy to install, Set of 2 (Note: See #3022 for original-type front spring).

**3001 SPORT LEAF SPRING, TRACK**

Lowers 1 1/2". Improves handling and appearance of your GT. Fairly stiff ride quality, can be used on street but best suited for autocross/racing applications. Should be used in conjunction with rear sport springs (3004). Installs with performance polyurethane bushings (3023), and induces a 2 degree negative camber (that can be adjusted out by rotating upper ball joints 180 degrees) Installation Instructions included.

**Original Front Spring Hardware**

**3022 SPRING EYE BUSHINGS, POLY**

Polyurethane. Designed for quick fit into original

**3022N SPRING EYE BUSHING, RUBBER**

Rubber. Located at either end of the original front leaf spring. Press-fit. Two (2) rubber bushings are required.

**3077 FRONT LEAF SPRING SADDLE / PERCH**

Front spring support plate. This piece sandwiches between the lower control arm and the front susp. cross member. Fits all year GT. Two (2) per car.

**3078 FRONT LEAF SPRING REPAIR KIT, RUBBER PARTS**

Nine piece kit (9) to re-bush the stock GT leaf spring. Includes end caps (2), upper cap (1), center isolators (2) and edge isolator pads (4). Note: Does not include the spring eye bushings 3022 or 3022N.

**3079 LEAF SPRING END CAP, POLYURETHANE**

This polyurethane end cap is used on each end of the stock GT front spring to keep the leaves from rubbing.

**3086 BOLT, SPRING EYE/LOWER CONTROL ARM**

Brand new bolt to replace those old rusted bolts. Often these bolts are rusted into the spring eye bushing and need to be cut off. Two (2) Bolts per front leaf spring.. Note: Does not come with nut.



3022

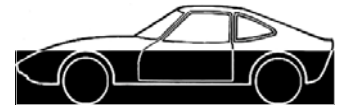

**Original Spring**

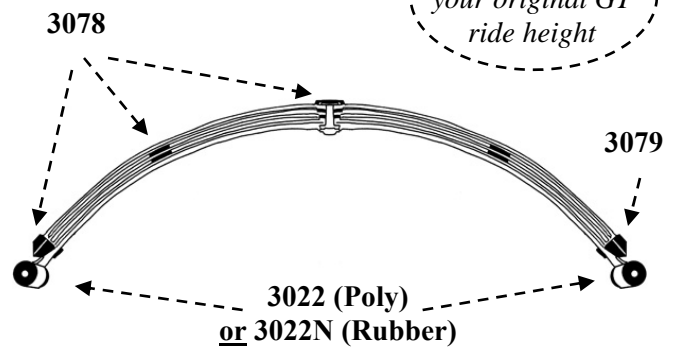

3078



3022 N

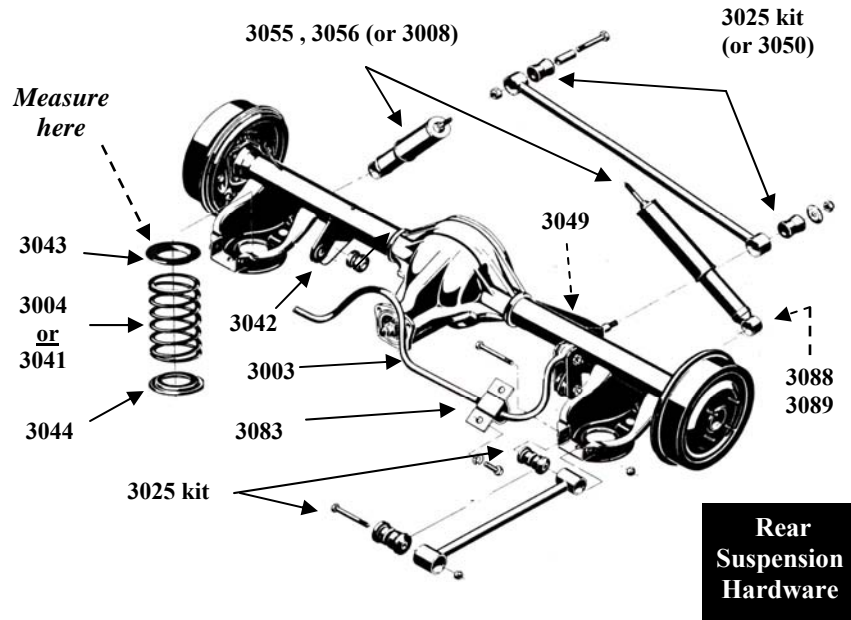

### Rear Springs & Hardware

#### 3004-1 SPORT REAR SPRINGS

1" lowering distance, a match for our 1" lowering front spring (part #3001). Great for street driving. Sold as a pair, uses our #3043 and #3044 spring hats and seats.

#### 3004-1.5 SPORT REAR SPRINGS

1 1/2" lowering distance, a match for our 1 1/2" front lowering spring (part #3001). For racetrack or hard Street driving use. Sold as a pair, uses our #3043 and #3044 spring hats and seats.

#### 3041 REAR SPRINGS, ORIGINAL HEIGHT

Helps restore original ride height, Sold as a pair. Best when installed with #3043 & #3044

#### 3043 UPPER SPRING HAT, POLYURETHANE

For use with original coil springs or our special lowering springs. To assure correct fit, specify year of car or measure diameter of mount location on underbody.

#### 3044 LOWER SPRING SEAT, POLYURETHANE

Between rear coil spring and axle spring cup.

### Rear Suspension Hardware

#### 3025 SPORT REAR SUSPENSION BUSHING KIT

Installation of this kit greatly improves handling, compared to the original rubber rear suspension bushings. Available in red or black, includes assembly notes.

Includes: Two (2) each: Front trailing arm bushings, rear trailing arm bushings, panhard rod bushings. Four (4) each trailing arm bushing sleeves (cadmium-plated), cad-plated trailing arm bolts & ny-lock nuts

#### 3050 PANHARD ROD BUSHINGS, POLYURETHANE

For rear panhard rod. Set of two (2).

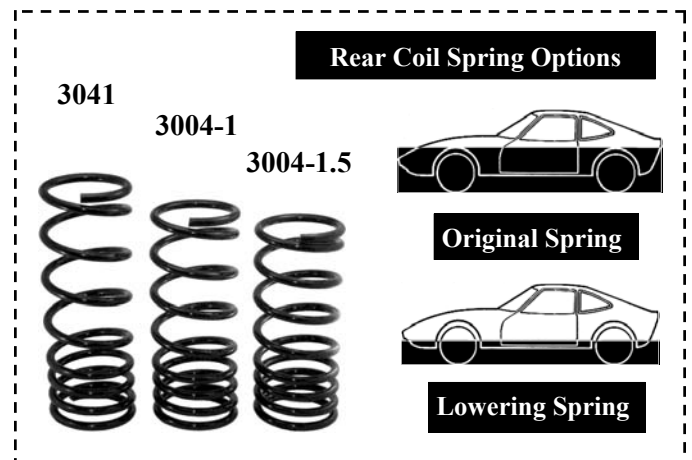

### Rear Shocks & Hardware

#### 3055 LOW PRESSURE REAR SHOCK

GT. Great for street and winding roads.

#### 3056 HIGH PRESSURE REAR SHOCK

GT. Great for street and winding roads.

#### 3008 KONI RED REAR SHOCKS

Top-of-the-line performance, good for both street and sport applications. Fully adjustable. Best when used in conjunction with 3007 Red Front Shocks.

#### 3088 REAR LOWER SHOCK MOUNT BUSHINGS, POLYURETHANE

Polyurethane lower shock mounting bushing for the stock rear shock absorber. Enhances shock absorber response.

#### 3089 LOCKNUT, REAR LOWER SHOCK MOUNTING

Brand new lock nut to replace your rusted or worn originals. 1x lock nut required per shock.



## Sway Bar Notes

Opel GT Source Sway Bars allow full suspension travel and enjoyment of the original Opel GT Suspension Geometry, by utilizing factory-designed mount locations from the driveline to the chassis.

*(Unlike other bars, which fall short by asking you to use improper locations such as the side of the rear spring cup).*

*Once installed, you can experience Opel GT driving (the way it was intended to be!).*

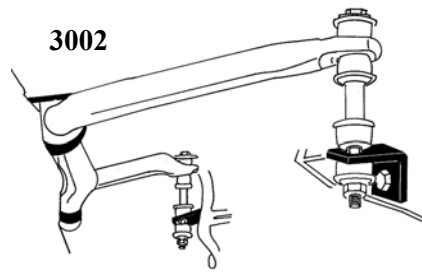

### Front Sway Bar

(Installed View)

*Kit includes J-bracket mounts to cross-member*

### Rear Sway Bar

(Installed View)

*Designed for mount at rear axle bracket*

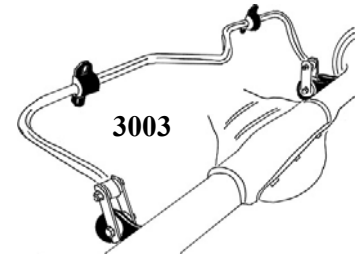

## **Front Sway Bar & Hardware**

### **3002 GT FRONT SWAY BAR**

Vastly increases handling and assists flat cornering (particularly when combined with #3003 rear bar). Bolts up to original factory sway bar locations. Solid 1" diameter. Features polyurethane bushings, all hardware, and brackets. Installation instructions included. NOTE: This part does not fit Kadett.

### **3084 SWAYBAR 'END LINK' BUSHINGS**

Polyurethane End Link bushings only. Contains 8x (eight) bushings. Available for stock, aftermarket and OGTS front sway bars.

### **3084K SWAYBAR 'END LINK' BUSHING KIT**

Polyurethane End Link bushings with bolts, nuts, washers and sleeves. Available for stock, aftermarket and OGTS front sway bars.



*Installation of correct-geometry sway bars helps keep weight distribution evenly divided between the tires. They also improve road adhesion by controlling wheel hopping and loose steering while increasing responsiveness, which allows for better acceleration due to increased traction..*

## **Rear Sway Bar & Hardware**

### **3003 REAR SWAY BAR**

Provides noticeable handling improvement. Bolts up to factory sway bar locations. 3/4" diameter. Features polyurethane bushings, all hardware and brackets. Improves handling characteristics and installs with ease! Best when installed with #3002  
*NOTE: Requires a factory sway bar rear axle or our aftermarket brackets (3042).*

### **3042 BRACKET, REAR SWAY BAR TO AXLE**

Needed to install a rear sway bar to a non-sway bar rear axle. Must be welded in place.

### **3049 POLYURETHANE BUSHINGS**

For original rear sway bar end link. Set of four (4). Must reuse your metal sleeves.

### **3083 SWAY BAR 'D' BUSHINGS, PAIR**

Polyurethane 'D' bushing with bracket. Available for stock, aftermarket and OGTS sway bars.



*Opel GT Source also offers add-on #3042 Axle Brackets, which allows owners of non-sway rear axles to upgrade with our #3002 rear sway bar kit..*



## Street Racer Shocks

### 3007 KONI RED FRONT SHOCKS

The ultimate handling upgrade for a performance-driven GT. Good for street and sport applications. Fully adjustable. Best when used in conjunction with 3008 Red Rear Shocks.

### 3008 KONI RED REAR SHOCKS

Top of the line performance, good for both street and sport applications. Fully adjustable. Best when used in conjunction with 3007 Red Front Shocks.

## Racetrack Shocks

### 3005 KONI YELLOW FRONT SHOCKS

Fully adjustable racing shocks. Excellent for a racing application. Not recommended for street application. Best when used in conjunction with 3006.

### 3006 KONI YELLOW REAR SHOCKS

Fully adjustable racing shocks. Excellent for a racing application. Not recommended for street application. Best when used in conjunction with 3005.

Reds



Yellows

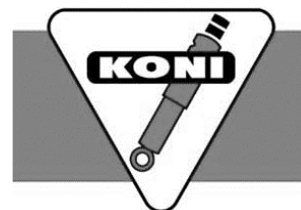

Koni shocks are fully adjustable. Koni Red shocks are for street and autocross use. #3007, #3008 Koni Yellow shocks are only for racing purposes. #3005, #3006



### HARD COMPOUND

For racing only!  
(Poly material;  
Measures "70" on  
the Durometer scale)

## Racing Bushings

### 3028 1969-1971 CONTROL ARM BUSHING SET, HARD

Hard compound replacement polyurethane bushings. Set of eight (8). For upper and lower control arms. For competition and racing applications. Also gives added stability with wider tires. Includes teflon grease and instructions.

### 3029 1972-1973 CONTROL ARM BUSHING SET, HARD

Hard compound replacement polyurethane bushings. Set of eight (8). For upper and lower control arms. For competition and racing applications. Also gives added stability with wider tires. Includes teflon grease and instructions.

### 3033 1969-1973 UPPER CONTROL ARM BUSHING, HARD

Hard compound polyurethane.

### 3034 1969-1971 LOWER CONTROL ARM BUSHING, HARD

Hard compound polyurethane. Inner diameter .710".

### 3035 1972-1973 LOWER CONTROL ARM BUSHING, HARD

Hard compound polyurethane. Inner diameter .745".

### 3061 TEFLON GREASE

Waterproof. Stops polyurethane from squeaking. Individually packaged.

## Suspension Notes

When properly equipped, the Opel GT is a car that provides a fun response comparable to that of driving a “go-kart” on the street! But 40 years of wear and neglect have in many cases reduced its handling stability. Fortunately, common maintenance and installation of our custom-designed reproduction parts can restore the original excitement to your GT's road response.

### Inspection

Evaluate your suspension by shaking the tires and visually checking suspension components for areas of looseness and play. Check steering components by shaking tires side-to-side. Check ball joints and arm bushings by shaking tires up and down. Test shock absorbers by bouncing the car at each corner and observing the response.

### Polyurethane bushings

This popular upgrade helps restore original control arm geometry (Be aware that outer control arm sleeves are reused on lower arms)

### Leaf Spring Tension

Consult instructions before disassembly of components involving the front transverse leaf spring, to avoid possible injury. Perform service with drivetrain in car, for stability and safety.

### Component upgrades

Special springs, sway bars, shocks, help remedy limitations of production designs. We offer rear coil springs to restore your GT's original height, or to complement our (lowered) front sport spring profiles.

*Additional suspension information can be viewed within the “tips” section of our website at: [www.opelgtsource.com](http://www.opelgtsource.com)*

### What's your “stance”?

*On a GT, profile adjustment is accomplished with our springs (to suit preferences for ride height and for road-handling). This can be complemented by your choice of wheels and tires.*

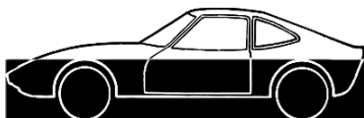

“Restored” (Original)

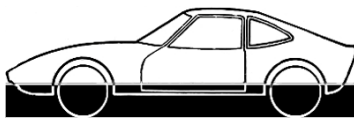

“Improved” (Lowered)

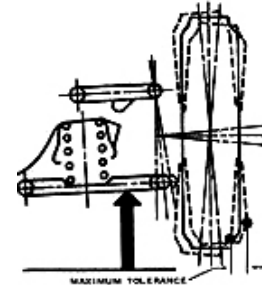

***Got a “55mph shimmy”?***  
*Inspect your suspension, then order the parts you need from our wide selection*

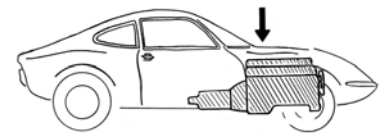

***Suspension Service***  
*Recommended with drivetrain in car, as weight is required to compress front spring.*

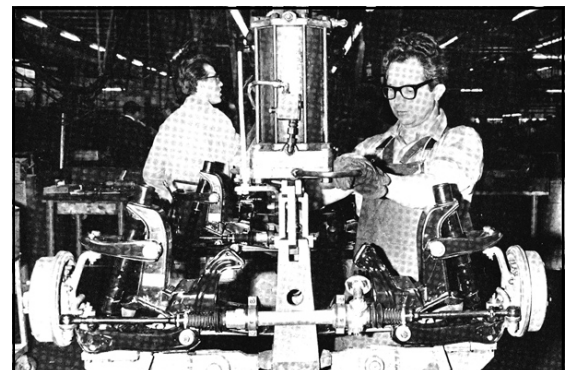





**3013 Upper Ball Joint**  
*Replacement item*



**3022 Front Spring Eye Bushings**  
Reproduction for Sport Springs  
*EZ install, poly with inner metal sleeve*



**3021 GT Rack Mount Bushings**  
Polyurethane, secures rack to frame  
*Steering response better w/less effort*



**3012 GT Rack Boots**  
All New Rubber, sold individually  
*Replaces cracked or missing boots*



**3026/3027 Front Suspension**  
Improved-Design Poly Bushing Set  
*Includes lubricant and installation notes*



**3025 Rear Suspension Bushing Set**  
Sturdy Polyurethane Productions  
*Includes hardware and lubricant*



**3076 Upper Shock Cup Bushings**  
Helps restore support and function in  
upper shock tower area



**3059 Metal Inner Sleeve Set**  
All New Metal sleeves for front  
suspension arms, select your size



**3333 Poly Dust Boots**  
Durable Polyurethane  
*Protects ball joints and outer tie rods*



**Used Suspension Parts available**  
*Contact Opel GT Source with your needs*  
[opelgts@opelgtsource.com](mailto:opelgts@opelgtsource.com)



**3043 Rear Spring Hat**  
**3044 Rear Spring Seat**  
Polyurethane. Sold individually.  
*Replaces worn-out original rubber piece*



**3095 Control Arm Gusset set**  
Weld-On Metal Plate set from Steinmetz  
*Helps reduce control arm flex.*



# 4000/Brakes



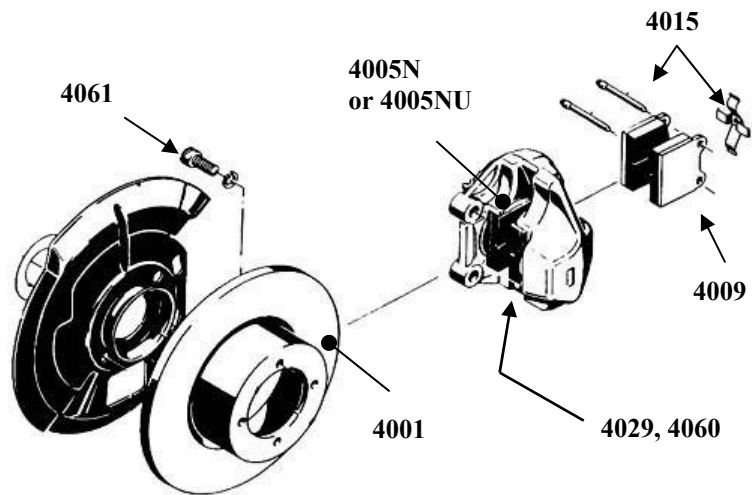
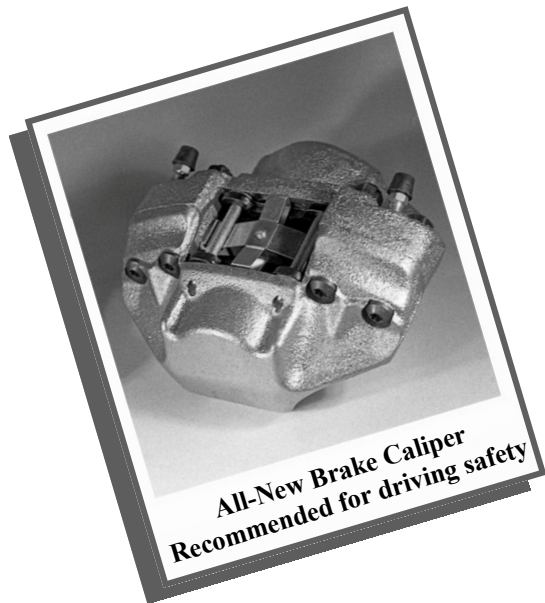

**Front Brakes**

**Front Brakes**

**4001 ROTOR**

Original front disc rotor. (Requires #12014 to install)

**4005N NEW, BRAKE CALIPER, LOADED**

All new brake caliper, includes with new brake pads, shims and pad hardware. Ready to install, recommended for optimal safety while driving. Can also be ordered as a matched pair, left and right. No Core deposit or exchange required on this item. *This item was developed when original caliper cores became harder to find in re-buildable condition, due to internal metal fatigue and corrosion.*

**4005U NEW, BRAKE CALIPER, UN-LOADED**

All new brake caliper, Same as #4005N above, but sold without pads or hardware. Ready to install. Can also be ordered as a matched pair, left and right. No Core deposit or exchange required on this item.

**4009 FRONT BRAKE PADS**

For original disc brakes. Semi-metallic.

**4015 FRONT BRAKE HARDWARE**

One set includes all the pins and clips needed to replace brake pads on both front calipers.

**4021 BRAKE HOSE**

High-Quality production, 3 required per car.

**4029 CALIPER REBUILD KIT**

For original front disc brakes, 48mm caliper bore.

**4060 SHIMS**

1968-1974 front brake pad shims. Set of four (4).

**4061 BOLT**

Brake rotor to hub. Four (4) required.

**12014 10mm SERRATED TOOL**

This tool is required to disassemble the front brakes. Offered as a convenience item. Not a Torx!

**Related Front Brake Hardware**

**3038 WHEEL BEARING, FRONT INNER.**

**3039 WHEEL BEARING, FRONT OUTER**

**3040 SEAL, FRONT WHEEL BEARING**

Cover to protect your wheel bearing from dust and dirt.

**3071 DUST CAP COVER**

Dust cap cover for front wheel bearing.

**7020 WHEEL LUG STUD, ORIGINAL LENGTH**

**7020XL WHEEL LUG STUD**

Longer 52mm length.

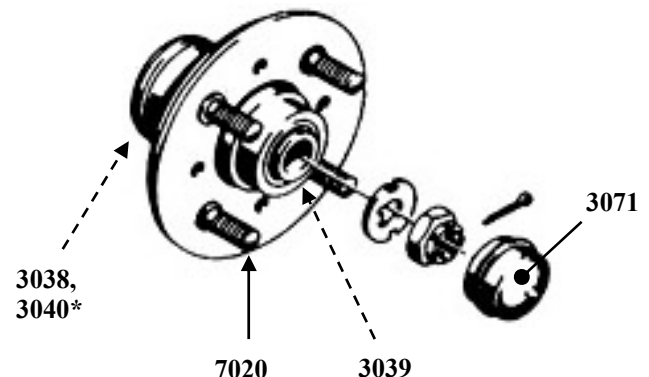

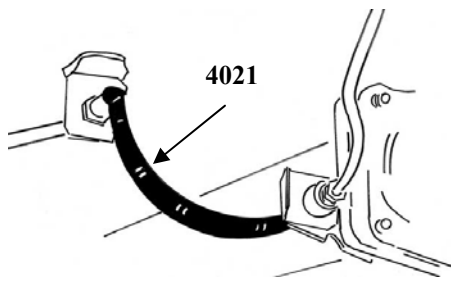

**4021 Rear Hose**

An often-overlooked maintenance item, this 3rd hose connects from the underbody to the rear axle. We recommend installing higher-quality hose here, to protect critical rear brake functioning.

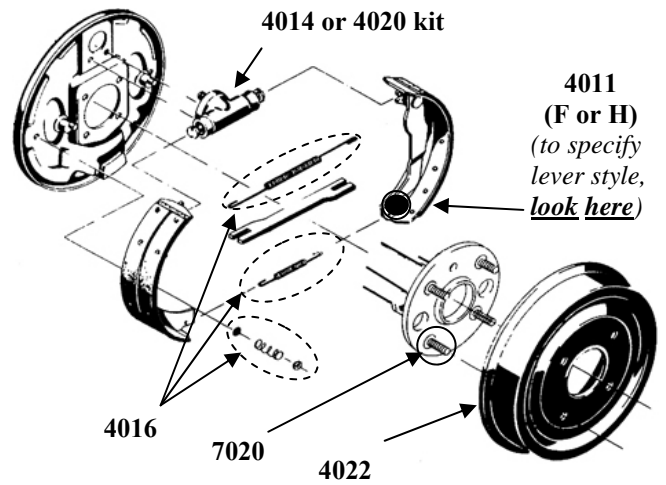

**Rear Brakes**

**Rear Brakes & Hardware**

**4011F REAR BRAKE SHOES, FOLDED**  
For rear drum brakes with folded-lever emergency brake shoe lever and ball end parking brake cable.

**4011H REAR BRAKE SHOES, HOOK**  
For rear drum brakes with hook-lever emergency brake shoe lever and stirrup end parking brake cable.

**4022 BRAKE DRUM**  
Aftermarket. Replica of original brake drum.

**4014 REAR WHEEL CYLINDER**  
For rear drum brakes.

**4020 REAR WHEEL CYLINDER REBUILD KIT**  
Includes 2 rubber inner piston cups and 2 dust boots.

**4016 REAR BRAKE HARDWARE**  
All the springs, clips and pins needed to replace rear drum brake shoes.

**4021 BRAKE HOSE**  
High-Quality, connects from underbody to rear axle



**4070**  
**Parking Brake Lever**

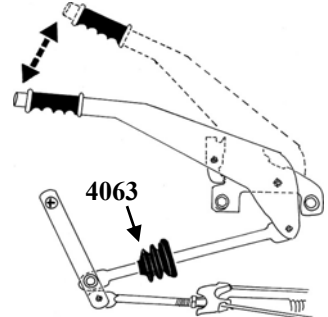

**Parking Brake Hardware**

**4012A PARKING BRAKE CABLE**  
A ball type cable for a folded-end type parking brake shoe lever. Original style on 1968-1971 GT's.

**4012B PARKING BRAKE CABLE**  
A 'hollow-rectangle' -end type cable for a hook type parking brake shoe lever. Original style 1972-1973 GT's

**4063 BOOT, PARKING BRAKE ROD, UNDERCHASSIS**  
This part is located on the underside of the GT where the hand-brake rod exits the floor board. Helps to keep fumes from entering the car.

**4070 HANDLE, PARKING BRAKE LEVER**  
Replacement new plastic "grip area" handle section

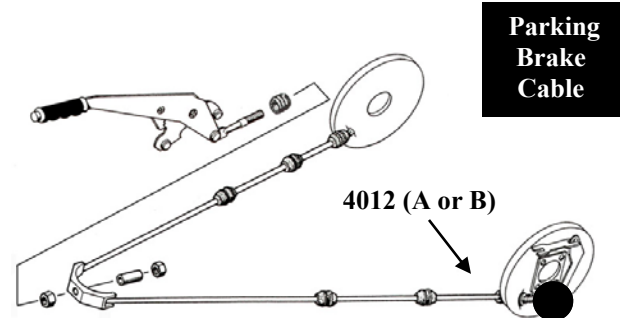

**Parking Brake Cable**

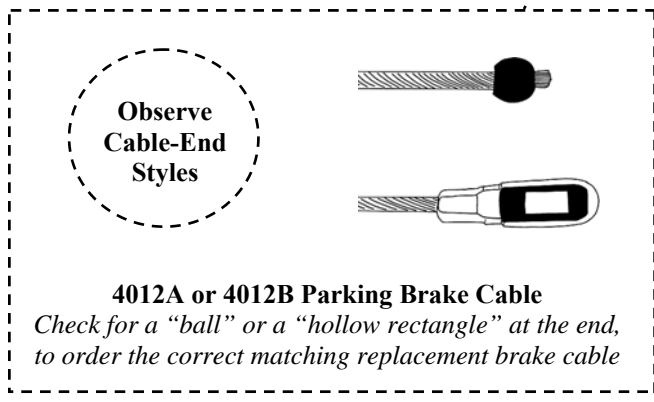

**4012A or 4012B Parking Brake Cable**  
Check for a "ball" or a "hollow rectangle" at the end, to order the correct matching replacement brake cable



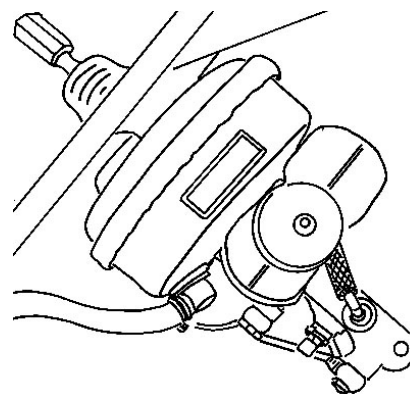
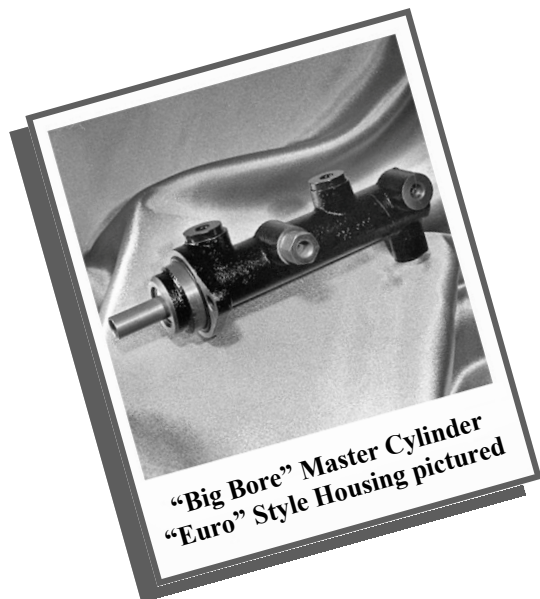

**Installed View: Original GT Master Cylinder & Booster**

*Outline shows hose connection & reservoir locations*

**"Big Bore" 22mm  
Master Cylinder**

Based on advancements by European GT tuners, where upgraded stopping power was required for driving the Autobahn, this unit has been adapted for modern-era Opel GT installations.

It's responsiveness (*comparable to "big brake" kits, when combined with our #4037-9 booster and calipers & rotors*) has made it a popular street-driver upgrade.

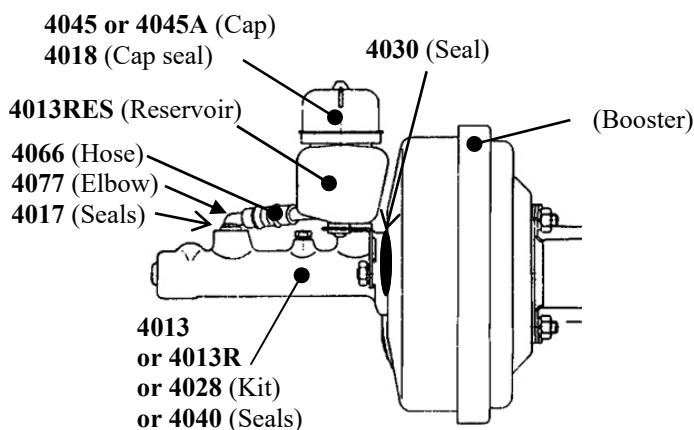
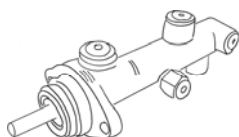

**Installed View: Master Cylinder & Booster**

*Outline shows hardware locations*

**Master Cylinder & Hardware**

**4013-22 22 MM "BIG BORE" MASTER CYLINDER**  
New. Improved big bore cylinder in a bolt-on unit. Includes reservoir seals and o-ring to booster. European style housing, deletes side switch assembly.

**4013 MASTER CYLINDER**  
New. Original capacity unit, limited availability. Does not include reservoir seals or o-ring to booster.

**4017 RESERVOIR SEAL SET**  
Master cylinder to brake fluid reservoir. Set of two (2), includes one larger seal and one smaller seal.

**4018 SEAL**  
Master cylinder cap to reservoir.

**4028 MASTER CYLINDER REBUILD KIT**  
New rebuild kit. Includes all seals, pistons, and hardware to rebuild upper section of the GT. See also 4017

**4030 SEAL**  
Master cylinder to booster. (Please specify if for original units, or if for larger #4013-22 with #4037-9)

**4013RES RESERVOIR FOR MASTER CYLINDER**  
New Plastic reservoir unit.

**4040 MASTER CYLINDER REBUILD KIT**  
Seals ONLY kit, for the main bore. See also 4017. NOTE: No metal pistons or hardware included!

**4045 MASTER CYLINDER CAP, POLISHED ALUMINUM**  
Prevents moisture from getting into the master cylinder. European reproduction.

**4045A MASTER CYLINDER CAP, PLASTIC**  
Low cost alternative master cylinder cap for the GT.

**4066 HOSE, MASTER CYLINDER to RESERVOIR ELBOW**  
This hose connects from the master cylinder elbow to the reservoir.

**4077 90 DEGREE ELBOW, MASTER CYLINDER to RESERVOIR**  
The elbow is located in the front port of your GT M/C





The "Combo": Upgrade your brakes for a response that feels like a modern car

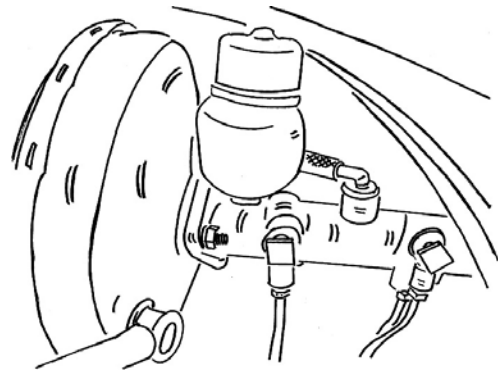

**Installed View of "Combo" Opel GT Upgrade  
"Big Bore" GT Master Cylinder & 9-Inch Booster**

*Outline shows hose connection & reservoir locations*

### GT 9-Inch "Big" Booster

#### 4037-9 NEW, 9" POWER BRAKE BOOSTER for OPEL GT

Opel GT Source's exclusive brand-new larger power brake booster! Gives your GT a modern brake pedal response. Available at a substantial lower cost than rebuilding your original. No Core Fee or Exchange required. Best paired with #4013-22 Master Cylinder. Also uses original-style vacuum hose (part #4041). *Incorporates built-in check valve into inlet fitting.*

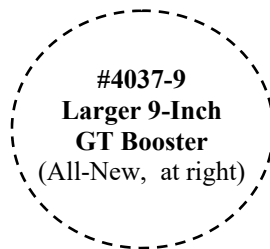

#4037-9  
Larger 9-Inch  
GT Booster  
(All-New, at right)



### GT Original Booster Hardware

#### 4019 SEAL

Vacuum booster inlet, seals elbow fitting.

#### 4030 SEAL

Master cylinder to booster.  
(Please specify if for original units,  
or if for larger #4013-22 master or #4037-9 booster)

#### 4041 BRAKE BOOSTER HOSE

Aftermarket. Special reinforced vacuum hose that resists pressure and will not collapse, replaces old fiber-wrapped original-style brake booster hoses.

#### 4053 BOOSTER VALVE

One way check valve for original vacuum booster hose. This located in booster hose near the intake manifold. *(Note: Aftermarket types may vary in appearance)*

#### 4064 BOOSTER ROD RUBBER BOOT

#### 4069 BRAKE PEDAL SPRING

Helps raise brake pedal for improved operation



4041  
(Booster Hose)



**Booster Check Valve**  
*(Original style shown;  
Appearance may vary)*

**Original-Style  
Booster Hardware**  
(as shown)

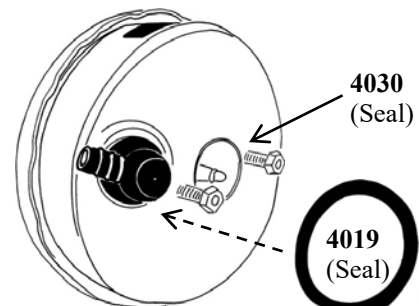

4030  
(Seal)

4019  
(Seal)



**Rubber Hoses: Replacement is part of system maintenance**

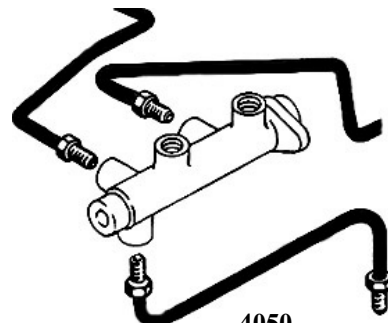

**4050**  
Brake Tubing Set  
(3 Hoses)

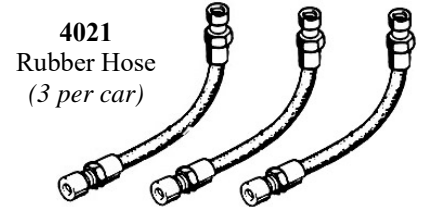

**4021**  
Rubber Hose  
(3 per car)

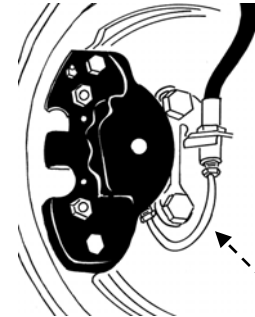

**4050-J**  
"J-Tube"  
hose

## Brake Hoses & Tubing

### 4021 BRAKE HOSE

Aftermarket. 3 required per car (2 front and 1 rear)

### 4021K BRAKE HOSE Set of 3

Convenient set of 3 rubber hoses fits one GT

### 4021SSK BRAKE HOSE, UPGRADED

Higher Quality Set of Brake Hoses, 3 fits one GT

### 4050 BRAKE TUBING SET

Set of "non-preformed" metal brake tubing. Includes the lines from master cylinder. (Does not include "J tube" hoses to individual front calipers).

### 4050J BRAKE "J-TUBE"

Short metal tubing section connecting to GT caliper. 2 per car.

### 4050JS BRAKE "J-TUBES"

Set of 2 short metal "J-Tubes," one for each side. GT

## "Big Brake" Components

### 4002 ROTOR, BIG BRAKE (1975 WIDTH)

**4002CD ROTOR, BIG BRAKE (1975 WIDTH)**  
Cross-Drilled.

### 4010 FRONT BIG BRAKE PADS

For front Big-Brakes brake calipers. Semi-metallic.

### 4010GS EBC KEVLAR FRONT BRAKE PADS

EBC Kevlar green-stuff, set of 4 front brake pads.

### 4010S ORGANIC FRONT BRAKE PADS

Organic front brake pads, for either 1975 Manta, 1900 & Wagon, as well as big-brake calipers.

### 4025 REAR WHEEL CYLINDER 3/4"

New 3/4 inch rear wheel cylinder.

### 4034 FRONT CALIPER HARDWARE (1975 STYLE)

### 4039 FRONT CALIPER REBUILD KIT (1975 STYLE)

### 4042 FRONT CALIPER, REBUILT (1975 STYLE)

Big Brake, Includes pads and pins. Core Exchange required.

### 4044 BRAKE HOSE

Steel braided, with fittings and adaptors for big brake package. Set of three (3). Front/Rear. Use with 4024.

## Performance Brake Hardware

### 4024 FRONT BIG BRAKE PACKAGE

Old-School approach to brake system enhancement. Includes two (2) 1975 big-brake rotors, two (2) rebuilt 1975-style big-brake calipers with brake pads and hardware and two (2) 3/4" rear wheel cylinders and three (3) braided steel brake hoses. Note: Cannot be used with some stock 13" GT wheels.

### 4002V VENTILATED BIG BRAKE ROTORS

For use with 1977 BMW calipers. Requires #4044 brake lines, special wheel sizes and slight machining of wheel hubs. Sold as a pair.

### 4003SP VENTILATED FRONT BIG BRAKE KIT

### 4009GS EBC KEVLAR BRAKE PADS

Fits stock 1968-1974 size calipers. Sold as a set of 4.

### 4009MM FRONT BRAKE PADS

Fits stock 1968-1974 size calipers. Metal Masters.

### 4044 BRAKE HOSE

Steel braided with fittings and adaptors for big brake package. Set of three (3). Front/Rear. Use with 4024.

### 4067 FRONT BRAKE HARDWARE

Vented Big Brake Caliper to Brake Pad.

## Brake Notes

Brakes are important. Not only do you need to stop as fast as you drive, but also to avoid sudden maneuvers (from less cautious drivers). Because many original Opel GT brake parts now show excessive amounts of internal metal fatigue, we offer a line of critical brake assemblies, including calipers, master cylinders & vacuum boosters manufactured from all-new materials and components.

### Quality

There are aspects of an Opel you can look to save money on, but Brakes are definitely not one of them! Always spend what it takes for quality, including new original-design parts, rather than trying to “make do” with rebuilds or non-original adaptations (which sometimes are marketed on price alone). Your driving safety and your life are certainly worth a few dollars more here!

### New Components

Original parts, even rebuilt units, often have internal metal fatigue. Consider our new components, like calipers, or our MC/Booster combination to provide a braking response that is compatible with modern driving conditions.

### Regular Maintenance

A critical task, this includes replacing brake fluid every 2 years with Dot 3 or Dot 4 equivalent, regular replacement of rubber hoses, and inspection and replacement of other parts such as pads, shoes, rotors and drums when they are worn. For added safety, wear goggles when performing bleeding or other service (where fluid may spray).

### Hose Service

Always use a 10mm line wrench to loosen soft metal connectors. Always start a connector slowly, to avoid cross-threading. Use a “tubing bender” tool when fitting metal brake lines on body.

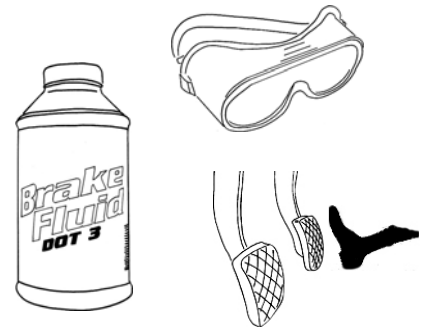
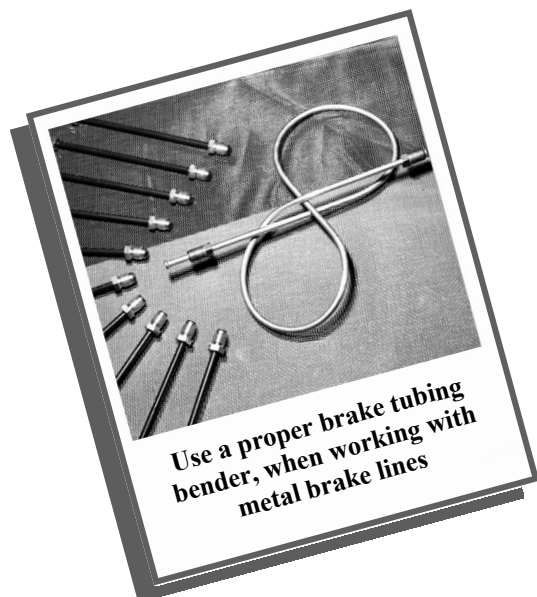

### ***Brake System Bleeding***

*A required maintenance service, best performed using proper fluid types while wearing goggles for safety.*

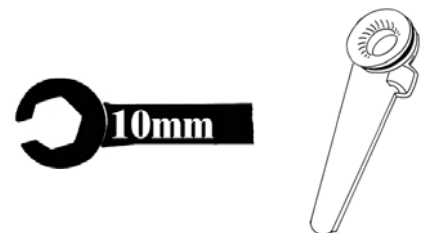

### ***Special tools***

*Use proper tools when servicing brakes, including wrench styles and benders made for the specific job*

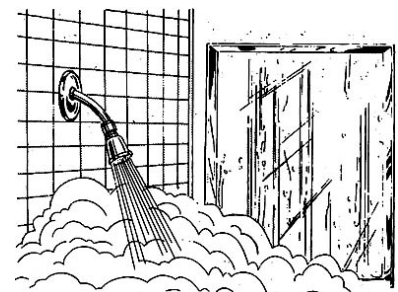

*Brake fluid absorbs moisture from the air, and regular replacement is required to avoid system corrosion.*





**4005 Caliper**  
All New. Available with  
pads & hardware if desired.



**4045A GT Master Cylinder Cap**  
Inexpensive plastic alternative



**4011 Brake Shoe Set**  
Indicate cable end style  
to match (attached) levers  
*No core fee or exchange required!*



**Used Brake Parts also available**  
Contact Opel GT Source with your needs  
[opelgts@opelgtsource.com](mailto:opelgts@opelgtsource.com)



**4013-22 GT Master Cylinder**  
All New, Big-Bore bolt-on design  
Road-tested, improved braking.



**4021K Opel GT Brake Hose Kit**  
New rubber GT Hose Kit, plus Hardware  
Fits original caliper styles. As Shown.



**5018 GT Brake Pedal Switch &  
4069 Brake Pedal Spring**  
Helps ensure proper brake pedal function



**4063 Parking Brake Lever Boot**  
Reproduction for Opel GT  
Insulates interior from body underside

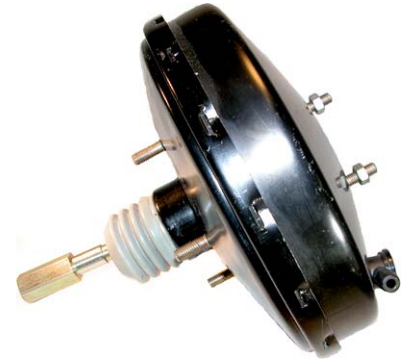

**4037-9 GT Booster**  
Exclusive Reproduction  
Better braking, with softer pedal feel



**4041 Booster Vacuum Hose**  
Reinforced Sturdier Design  
Resists collapsing better than other styles



**4053 Vacuum Check Valve**  
Replacement valve, fits in hose to  
brake booster from intake manifold



**4045 GT Master Cylinder Cap**  
Metal & Plastic Reproduction  
Shiny metal top, Imported from Europe



**5000/Electrical**

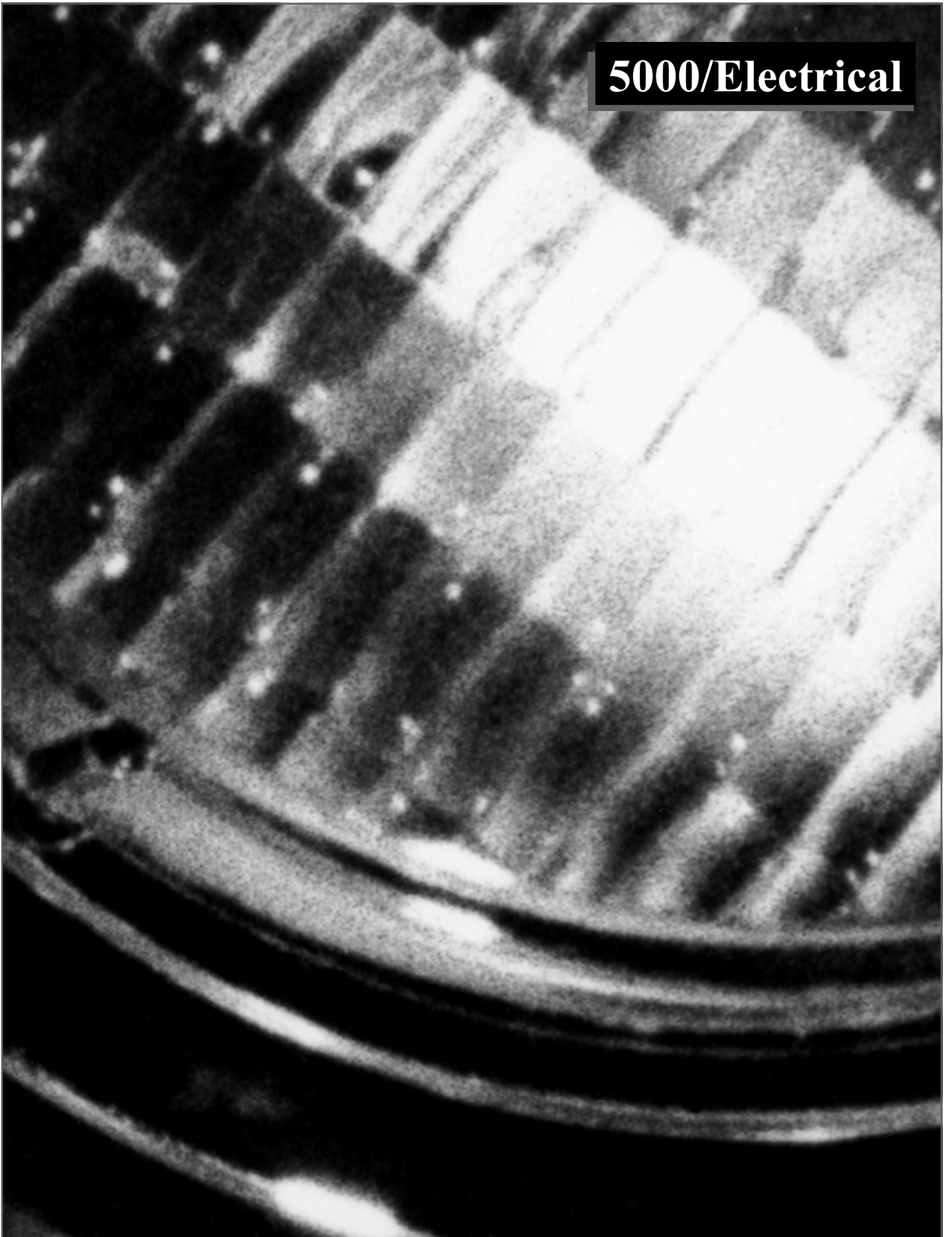

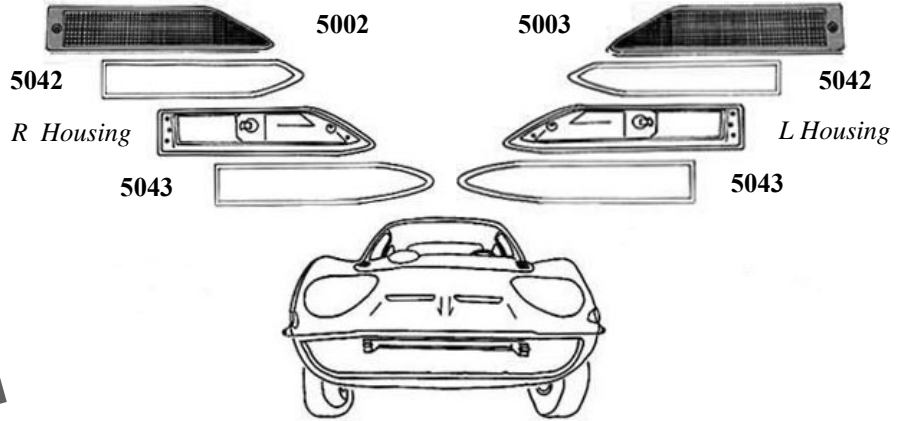
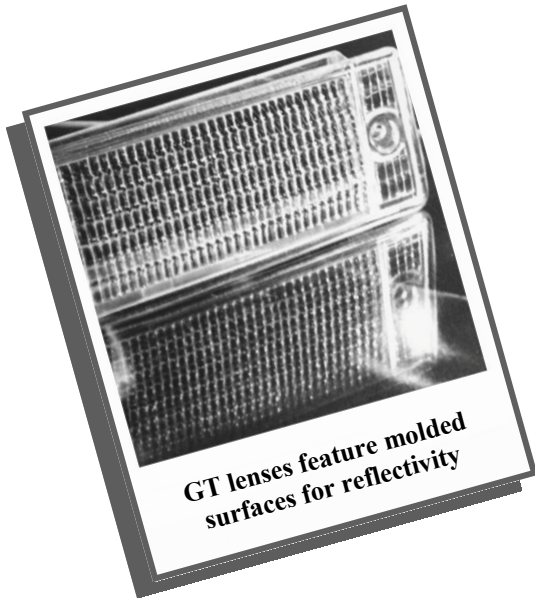

### Front Curved Marker Lights

**5002 RIGHT FRONT CURVED LENS, AMBER**  
New reproduction lens, Original lens appearance, but without the internal reflector. Best installed as a pair. Also in smoke (#5002G) or clear (#5002C) colors

**5003 LEFT FRONT CURVED LENS, AMBER**  
New reproduction lens, Original lens appearance, but without the internal reflector. Same as #5002 above, but fits driver's side. Best installed as a pair. Also in smoke (#5002G) or clear (#5002C) colors

**5042 GASKET**  
Fits between front curved lens and front curved housing. Reproduction.

**5043 GASKET**  
Fits between front curved housing and body. Left or right. Reproduction.

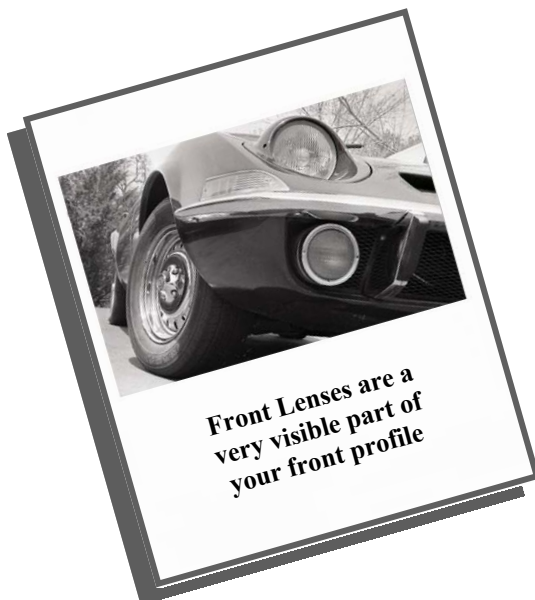

### 5080 SCREW

Front Curved Marker Lens to Housing, 20mm length.

### 5267 BULB

Fits all original style front curved marker lights. Correct wattage single-element light bulb for this application. Note: Standard auto part stores sell incorrect lower-wattage domestic bulbs.

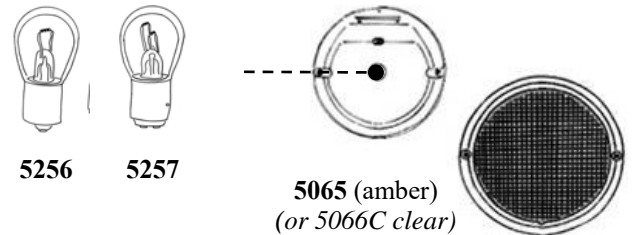

### Front Round Lights

#### 5065 FRONT ROUND LENS, AMBER

New reproduction lens, upgrades appearance & safety (Also available as part #5066C, see details on website)

#### 5082 LED FRONT LIGHT KIT

New retrofit kit provides modern look with options Includes #5082H harness and installation notes.

#### 5256 BULB

Fits 1968-1970 style parking light circuit. Proper European high-watt single-element light bulb for this application. Note: Standard auto part stores sell incorrect lower-wattage domestic bulbs.

#### 5257 BULB

Fits 1971-1973 style turn signal/parking light circuit. Proper European high-watt dual-element light bulb for this application. Note: Standard auto part stores sell incorrect lower-wattage domestic bulbs.

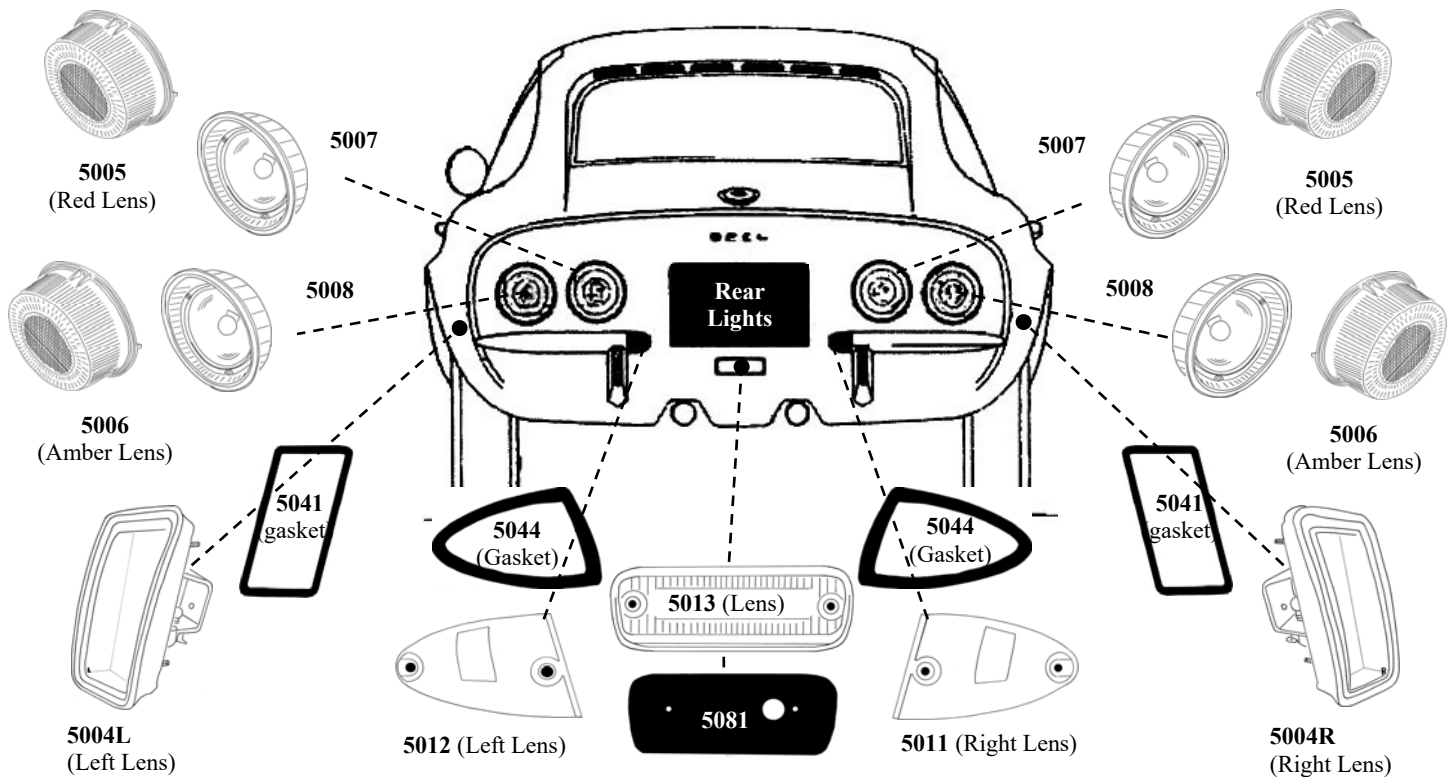

## Rear GT Lights 1968-72

### 5004R REAR SIDE MARKER, RIGHT

Replace your old, oxidized, broken or missing side marker light with this new bright side marker. *NOTE: Utilizes light bulb holder & support brackets removed off the old side markers. Reproduction*

### 5004L REAR SIDE MARKER, LEFT

Same as #5004R above, but for driver's side. *NOTE: Utilizes light bulb holder & support brackets removed off the old side markers. Reproduction*

### 5005 RED BRAKE LENS

A bright new red lens that installs in seconds to replace a typical old, aged brake light lens. Gives your car a newer appearance while making your brake lights brighter and more visible. Reproduction. Don't forget to also order a new bulb today. 5257

### 5006 YELLOW INDICATOR REAR LENS

A bright new amber lens that installs in seconds to replace a typical old, aged brake light lens. Gives your car a newer appearance while making your indicator lights brighter and more visible. Reproduction. Don't forget to also order a new bulb today. 5256

### 5007 REAR BRAKE LENS HOUSING

Replace your old, oxidized brake light housing with a new bright housing. Improves safety and appearance, as a bright chrome surface stands out where it visibly separates the lens from your exterior paint. Reproduction. *NOTE: Utilizes bulb holder removed from the old housing. Don't forget to order gaskets #5009/#5010 and a new bulb today. 5257*

### 5008 REAR INDICATOR LENS HOUSING

Same as #5007, but for turn signal lights 1968-1972. Reproduction. *NOTE: Utilizes bulb holder removed from the old housing. Don't forget to also order gaskets #5009/#5010 and a new bulb today. 5256*

### 5011 RIGHT LICENSE PLATE LENS

Replace your old, oxidized license plate lens with a new bright lens freshly chrome plated and protected against oxidation. Fits on the inside end of the right bumper. Also helps complete a replacement set of rear bumpers. Reproduction. Don't forget to also order a #5044 gasket and a new bulb today. 5267

### 5012 LEFT LICENSE PLATE LENS

Same as #5011, but for driver's side rear lens. Reproduction. Don't forget to order a new bulb today. 5267

### 5013 REVERSE LENS

New clear lens, replaces old, faded and dull original. Fits 1968-72 GT. Reproduction. Best when ordered with a new gasket #5081 and a new bulb #5031LED.

### 5081 RUBBER GASKET FOR REVERSE LENS

Replaces dried-out original gaskets. Fits 1968-72 GT.

### 1973 Opel GT

*Note: Later 1973 Opel GT's\* shared rear round lenses and housings with the Opel Manta.*

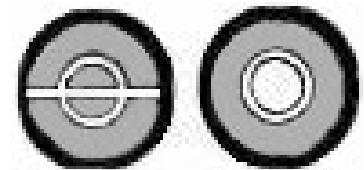

*\*After chassis #77-3100995*

## Rear Light Gaskets & Screws

### 5009 GASKET

Between tail light lens and tail light housing.  
Helps keep exhaust & dirt from entering lens & car.

### 5010 GASKET

Between tail light housing and body. Helps keep exhaust fumes from entering inside car. Reproduction

### 5041 GASKET

Between rear side marker & body. Left or right. Repro.

### 5044 GASKET

Between license lens and bumper housing. L or R.

### 5081 GASKET FOR REVERSE LIGHT

Rubber. Fits 1968-1972 Opel GT.

### 5555 SET OF GT LENS GASKETS

Includes 12 gaskets for GT front, side and rear lights.  
Fits 1968-1972 GT. (Does not include #5081 gasket)

### 5079 SCREW, LENS TO HOUSING

Fits Taillight or License Lens to Housing. 16mm length

## GT Rear Light Bulbs

### 5031 BACK-UP LIGHT BULB

For 1968-1972 GT Reverse Light (Rectangular lens)

### 5031LED BACK-UP LIGHT BULB, LED

Higher Intensity Bulb, fits same as original.

### 5256 TURN SIGNAL BULB

Fits 1968-1973 GT Rear Turn Signal  
Proper European high-watt single-element light bulb for this application. Note: Standard auto part stores sell incorrect lower-wattage domestic bulbs.

### 5257 BRAKE & PARK LIGHT BULB

Fits 1968-1973 GT Rear Brake/Parking Light  
Proper European high-watt dual-element light bulb.

## GT Clear "European Look" Lenses

### 5002C RIGHT FRONT CURVED LENS, CLEAR

New reproduction lens, looks best when installed as a pair. Original lens appearance, but without the internal reflector. Euro-Style "Clear" version.

### 5003C LEFT FRONT CURVED LENS, CLEAR

New reproduction lens, looks best when installed as a pair. Original lens appearance, but without the internal reflector. Euro-Style "Clear" version.

### 5066C ROUND FRONT LENS, CLEAR

New Reproduction. Moulded plastic, pair fits existing GT round light housings. See website for details

### 5156 CLEAR TAILLIGHT LENS SET

Four clear rear round lenses. Inquire for availability.

### EURO FRONT PASSING LENSES, GLASS

Special Order items. Inquire for availability.

## Turn Signal

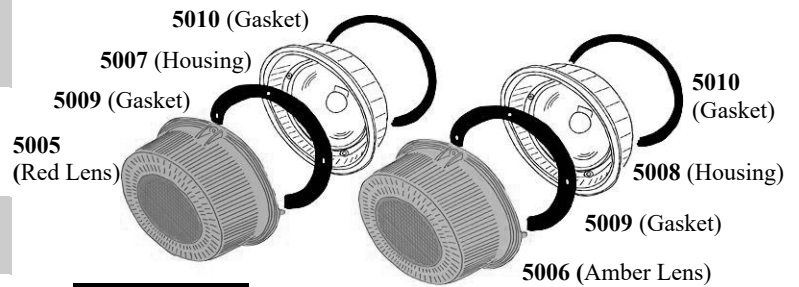

## Brake Light

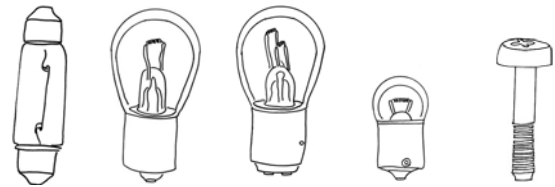

5031 5256 5257 5267 5079

(Note: Bulbs & Screw are not illustrated/shown to scale)

### 5267 REAR SIDE MARKER BULB

Fits 1968-1973 GT Rear Side Marker Light.  
Proper European high-watt single-element light bulb for this application. Note: Standard auto part stores sell incorrect lower-wattage domestic bulbs.

### 5267 LICENSE LENS BULB

Fits 1968-1973 GT License Plate Light.  
Proper European 21W (watt) single-element light bulb for this application. Note: Standard auto part stores sell incorrect 18W domestic bulbs.



Rear Lenses  
In Clear



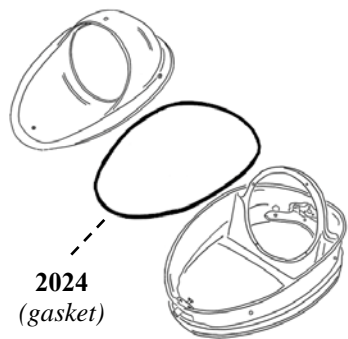

**2024**  
(gasket)

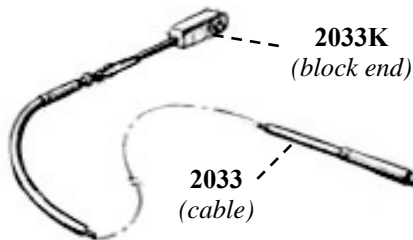

**2033K**  
(block end)

**2033**  
(cable)

**2033K**  
(pivot ball)

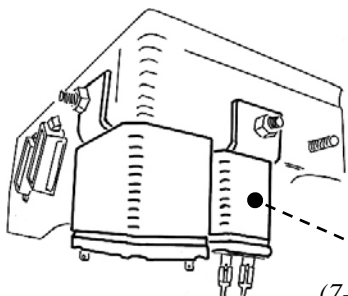

**5069**  
(7-wire main relay)

**5016,  
5016A,  
or 5016B**  
(Bulb Sets)

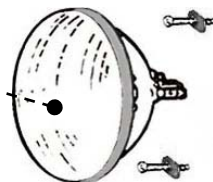

**5068**  
(plate)

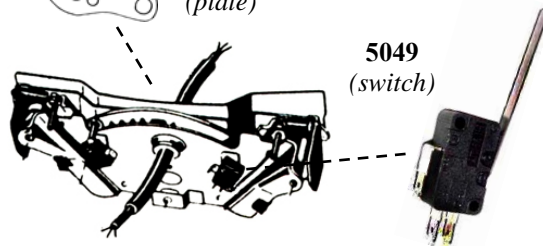

**5049**  
(switch)

## Headlights & Hardware

### 2024 GT HEADLIGHT BUCKET GASKET

Rubber "O" ring gasket between headlight bucket and headlight cover. Reproduction.

### 2033 GT HEADLIGHT CABLE

Replace a hard-to-operate or sticking cable with this new, quality reproduction of the GT head light cable. Helps restore smooth operation of headlights.

*Note: Cable requires re-use of existing hardware.*

### 2033K GT HEADLIGHT CABLE END HARDWARE

Includes end block & pivot for lever. *Details on website*

### 5016 HELLA H-4 HALOGEN HEADLIGHTS

Provides a much more powerful beam so you can see hazards quicker and better when driving at night.

When replacing a halogen light, you only need to change the bulb, not the entire light (as you would with an original sealed-beam).

Comes complete with 60/55 watt bulbs. Set of two (2).

### 5016A HALOGEN HEADLIGHT KIT, AFTERMARKET

Rounded face style, lower priced halogens for visibility at night. Comes with 60/55 watt bulbs. Set of two (2).

### 5016B HELLA H4HEADLIGHT

New European 7" round face design, will fit H4 bulb of your choice (bulb not included). Lowest price option

### 5049 MICROSWITCH

For headlight mechanisms. Switches headlight relays to turn headlights on or off, and also triggers white headlight indicator light on dash. Often replaced during part reassembly after a paint project. *Most GT's require 3 microswitches (some 1968-69 GT's have 4).*

### 5061 GT HEADLIGHT RELAY

New design fits into existing GT headlight relay metal housing. This is the "7-wire" main relay.

### 5067 GT HEADLIGHT MECHANISM REPAIR KIT

Hardware kit to repair your mechanism. Select L or R

### 5068 GT HEADLIGHT MECHANISM FLEX PLATE

Thin metal plate held w/8mm bolts. Sold individually

### 5069 HEADLAMP ADJUSTER NUT

Threaded nylon, fits GT

### 5077 HEADLIGHT SOCKET PLUG

Includes 3 attached 10" long wires. Part of a headlight re-wiring project (safety requirement for all Opel GT's)

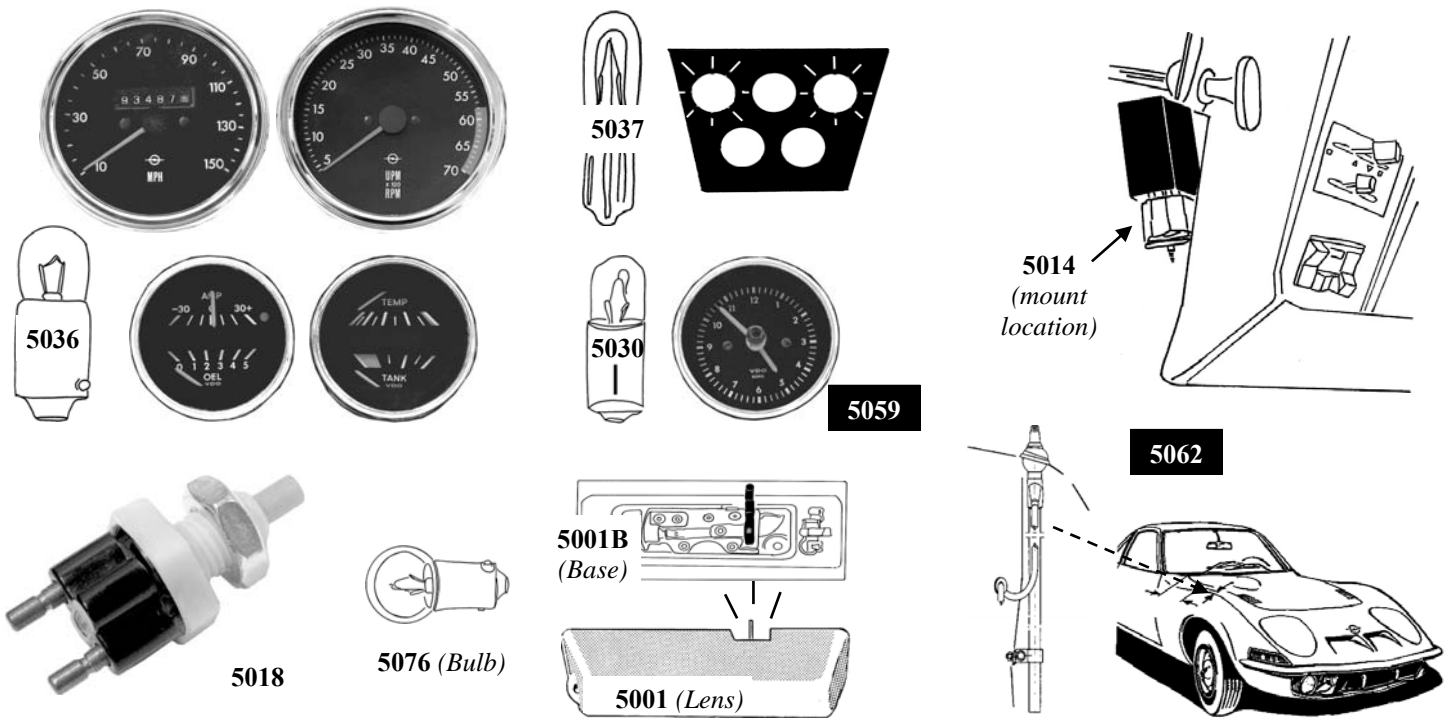

## GT Interior Electrical

### 5001 DOME LENS

Brighten up your interior by replace your old yellowed and dingy dome lamp lens with our brand new lens.

### 5001B DOME LENS BASE

Metal backing plus new switch and bulb holder

### 5076 DOME LIGHT BULB

For GT dome lamp base. *Also fits orig. Delco AM rad*

### 5014 TURN SIGNAL RELAY, UPGRADED for GT

If your GT is experiencing the typical "double flash" problem when activating your turn signal, then this 'New-Series' relay is the solution. Includes install notes

### 5018 BRAKE PEDAL SWITCH

Brake pedal switch for brake lights.

### 5030 GT CLOCK LIGHT BULB

Also fits console in GT's with automatic transmission

### 5036 DASH LIGHT BULB.

For dash gauges. 6-8 required for most gauge panels

### 5037 DASH LIGHT BULB

For 1970-1973 dash indicators. "Thin" style. 6 to 8 req

### 5052A OIL TEMPERATURE & VOLTMETER GAUGE

Fits original GT gauge panel, as replacement for clock

### 5054 OIL TEMP SENDER

Fits engine to work with #5052A oil temp gauge design

### 5059 GT CLOCK

New reproduction of original-design Opel GT clock.

### 5062 ANTENNA

German Made OEM for original fender mount

## GT Steering Column

### 5060N GT IGNITION SWITCH

New replacement electrical switch, fits in steering column. Helps cure intermittent operation, sometimes experienced with failing switch. Comes w/install notes

### 5064 TURN SIGNAL RING, 1970-1973 GT

Reproduction 1970-1973 Opel GT turn signal ring. Replaces a commonly-broken internal ring. Complete with switch and wire pigtail to facilitate your repair. Includes momentary contact switch for high/low beam

### 5084 TURN SIGNAL LEVER, 1969 GT

Includes "button" on the end of TS lever for high-beams. Can also be adapted to activate passing lights.

### 12110 STEERING WHEEL HUB PULLER KIT

Includes required special-design removal bits.

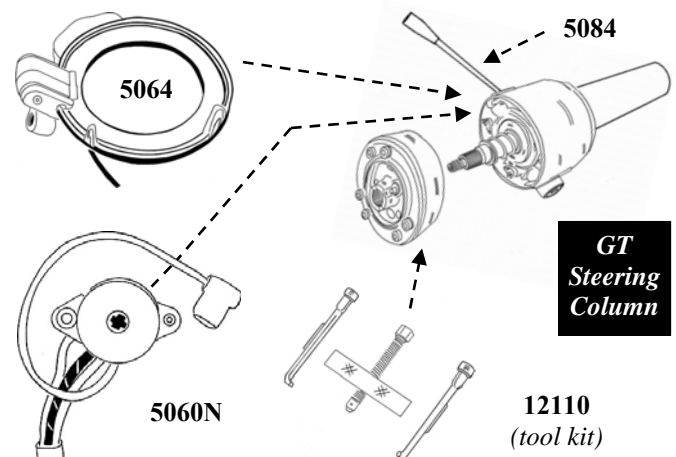

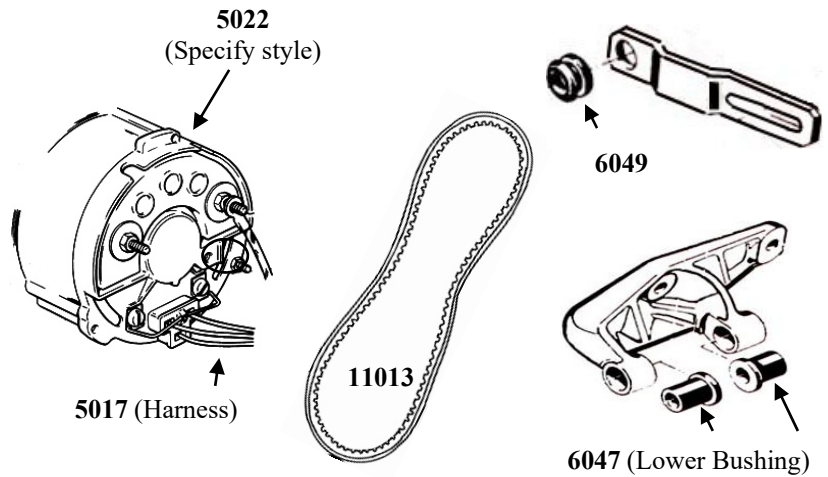

## Charging System

### 5022 ALTERNATOR

Rebuilt alternator. Specify if original or high-amp design when ordering. Core exchange item.

### 5022IR ALTERNATOR

Internally regulated design. 45 amp or greater output.

### 5017 HARNESS (ALTERNATOR to REGULATOR)

Replaces the typically-brittle original alternator to regulator 3-wire harness and end connectors. Helps repair intermittent alternator/regulator function.

### 5055 GROUND WIRE

Connects alternator casing to engine block bracket.

## Battery Hardware

### 5019 BATTERY BOX

New replacement box, sturdy steel construction  
(Also available in stainless steel as #5019SS)

### 5025 BATTERY CABLE, POSITIVE

Long length for Opel GT, connects to starter solenoid

### 5026 BATTERY CABLE, NEGATIVE

Braided design for GT battery to chassis ground

### 5075 BATTERY TERMINAL CONNECTOR

Quick-disconnect design for easier storage preparation

### 5078 ENGINE GROUND STRAP

Connects from engine block to GT chassis

## Fusebox & Related

### 5024P FUSEBOX HOUSING

Replacement box in plastic.

### 5024S FUSEBOX HOUSING

Metal replacement box made of steel.

### 5029 FUSE PACK

Contains an assortment of original fuses.

**5021A VOLTAGE REGULATOR, AFTERMARKET**  
Solid-State, lower cost alternative to OEM part

### 5050 VOLTAGE REGULATOR

For alternator, aftermarket. Least expensive version.

### 6047 LOWER ALTERNATOR BUSHING

Extends life of alternator, water pump and other engine front hardware by dampening vibrations. Sold individually. Two (2) required.

### 6049 UPPER ALTERNATOR BUSHINGS

Between bracket and timing cover. Set of two (2).

### 11013 FAN BELT

Specify your application for correct length (refer to our print-version "part list" for identification details)

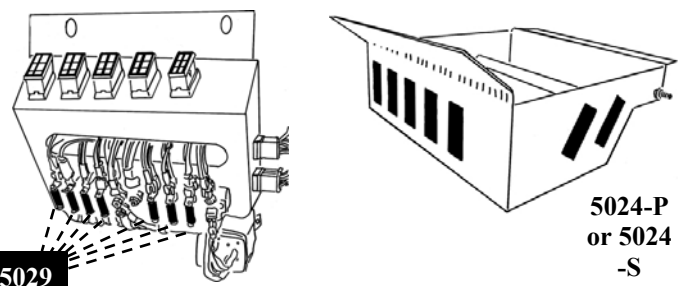
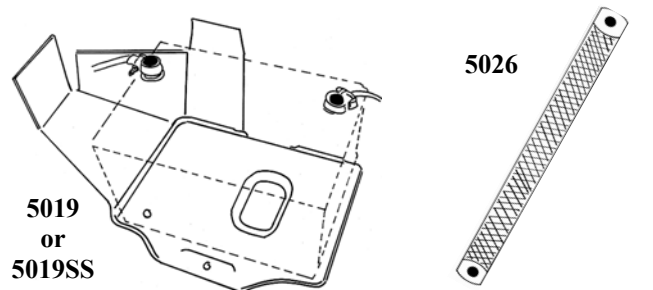



We offer an extensive line of tuning parts & upgrades

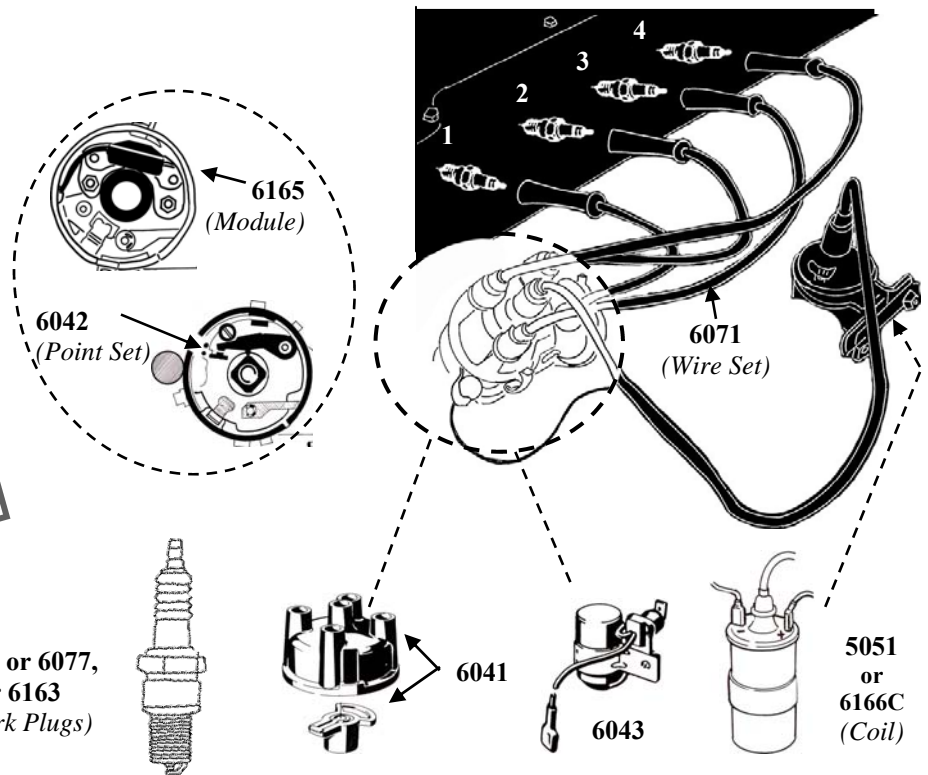

6040, or 6077,  
or 6163  
(Spark Plugs)

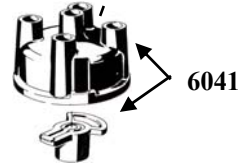

## Engine Electrical Parts

**6040 SPARK PLUGS, STANDARD**  
Standard, dependable operation, Champion

**6163 SPARK PLUGS, UPGRADED**  
Higher-Performance operation, Copper-core NGK

**6077 SPARK PLUG SET, PLATINUM**  
Premium-quality Bosch Platinum Spark Plug set of 4

**6041 DISTRIBUTOR CAP AND ROTOR**  
Cap & Rotor for 1970 thru 1975 1.9L distributors.  
(Refer to our print-version "part list" to identify style)

**6041-69 DISTRIBUTOR CAP AND ROTOR**  
Cap & Rotor for 1968 & 1969 distributors.  
(Refer to our print-version "part list" to identify style)

**6042 CONTACT POINTS**  
Ignition contact points, for 1968-1974 distributors.

**6134 CONTACT POINTS**  
Ignition contact points, for 1975 FI distributor.

## Starter & Switch

**5027PM STARTER**  
All-New Permanent Magnet starter. Powerful!  
A lightweight, high-torque bolt-on design that cranks Opel engines faster than original-design starters. Recommended on all Opel engines (esp. hi-perf), and also helps with the "hot re-start" problem (sometimes experienced with ethanol-mix fuels).

**5060N GT IGNITION SWITCH**  
New replacement electrical switch, fits in steering column. Installation notes available.

## 6043 CONDENSER

Condenser for ignition points. Provide style of distributor or model-year of vehicle for matching application.

**6071 IGNITION WIRE SET, TAILORED**  
Tailored silicone spark plug and coil wire set.

**6078 DISTRIBUTOR CAP, COLORED**  
See-thru yellow, blue or red for 1970-74 distributors

**5051 IGNITION COIL**  
OEM correct original impedance coil for Opel GT  
Proper voltage range prevents arcing within cap

**6165 IGNITION POINTS ELECTRONIC CONVERSION KIT**  
Electronically controlled ignition trigger that eliminates the need for points and condenser improves throttle response. Simplifies tune-ups, helps ensure consistent dwell readings, and gets rid of the points forever! This is a top-quality name-brand kit.

**6166C PERFORMANCE IGNITION COIL**  
Special coil designed for use with #6165 kit

**6165-2 IGNITOR-2 KIT**  
Upgraded version of electronic conversion kit

**6166-2 IGNITOR-2 COIL**

**6122 OPTICAL IGNITION KIT**

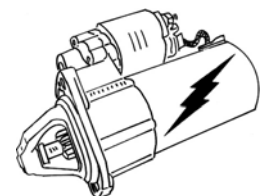



# Electrical Notes



One of the most attractive features of the Opel GT, are its uniquely designed and styled exterior lights, including its patented “roll over” headlamp assemblies. To keep your car looking good, Opel GT Source has stepped forward to make new reproduction lenses and related exterior light hardware available at a very reasonable price to you. We also offer many additional electrical system maintenance items.

## Headlight Wire Inspection

A substantial safety risk, inspection of these critical wires is a requirement for all classic Opel GT's. Instructions on wire harness replacement instructions (using common materials) are available online.

## Electrical Circuit Testing

Circuits and functions should be tested individually.

You can consult related electrical system notes on our website. They describe how Opel wiring harnesses are based on European standards (ie brown = ground), and illustrate areas to check (such as critical power and chassis ground locations).

## Starting and Ignition Circuits

Opel starting and ignition circuits also require special attention, to verify the presence of a resistance wire or ballast (for proper impedance to the ignition coil) and for recommended installation of a protective relay (to help deal with a common ignition switch failure syndrome).

## Taillight Gaskets

These are an important safety item, as they help insulate lenses to prevent exhaust fumes from being drawn into the vehicle interior.

*Additional Opel electrical system and engine tuning information (including timing and other specifications) can be viewed via downloads located on the “tips” section of our website, at: <http://www.opelgtsource.com>*

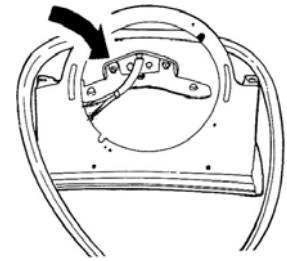

**Headlight Wiring**  
*Wire inspection required here*



**Electrical Inspection**  
*Check and note functions of all circuits*

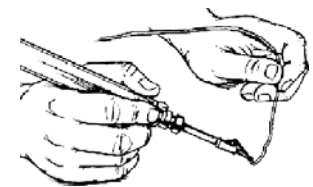
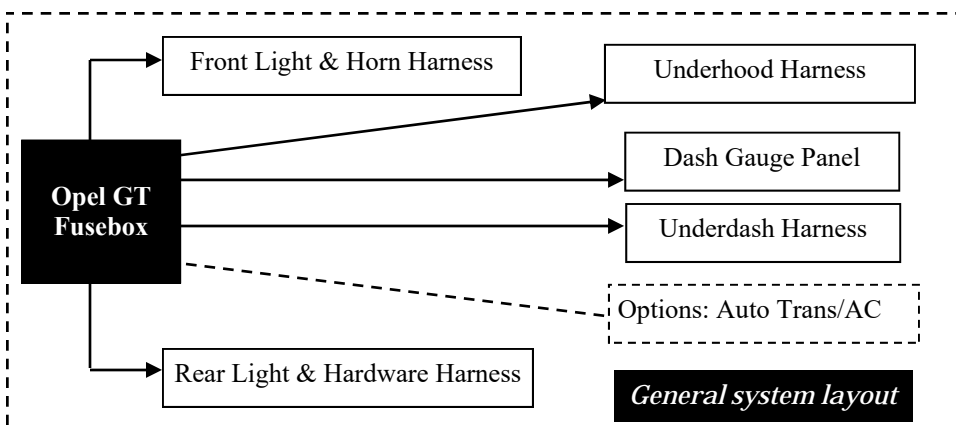

*Research GT harness layouts and how to repair them, using just splices and solder.*

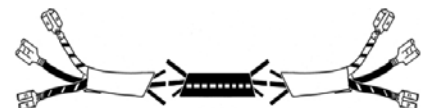



**5027PM Starter**

Higher-Torque, Lighter weight  
Recommended for faster re-starts



**5011 GT Right License Lens**  
New Reproduction



**5012 GT Left License Lens**  
New Reproduction



**Used Electrical Parts also available**  
Contact Opel GT Source with your needs  
[opelgts@opelgtsource.com](mailto:opelgts@opelgtsource.com)



**5005 GT Brake Lens**  
New repro. Fits 1968-1972 Opel GT



**5006 GT Turn Signal Lens**  
New repro. Fits 1968-1972 Opel GT



**5002 Front Curved Lenses**  
Passenger Side, New Reproduction  
Available in amber, clear or smoke



**5003 Front Curved Lenses**  
Driver's Side, New Reproduction  
Available in amber, clear or smoke



**5004 Rear Side Marker**  
New reproduction lens  
Select Right, Left or Both sides



**5059 GT Clock**  
All new housing, dial and internal gears  
Original design, working clock



**5065 Front Round Lenses Amber or 5066C Front Round Lenses, Clear**  
Greatly upgrades GT front appearance



**5064 GT Turn Signal Ring**  
Reproduction item  
Replaces broken ring in Steering Column



**5017 Harness Alternator-Regulator**  
Helps restore charging system  
Includes new plastic end plugs and wires



**5060N GT Ignition Switch**  
New Switch plus Harness  
Installation notes included.



# 6000/Engine

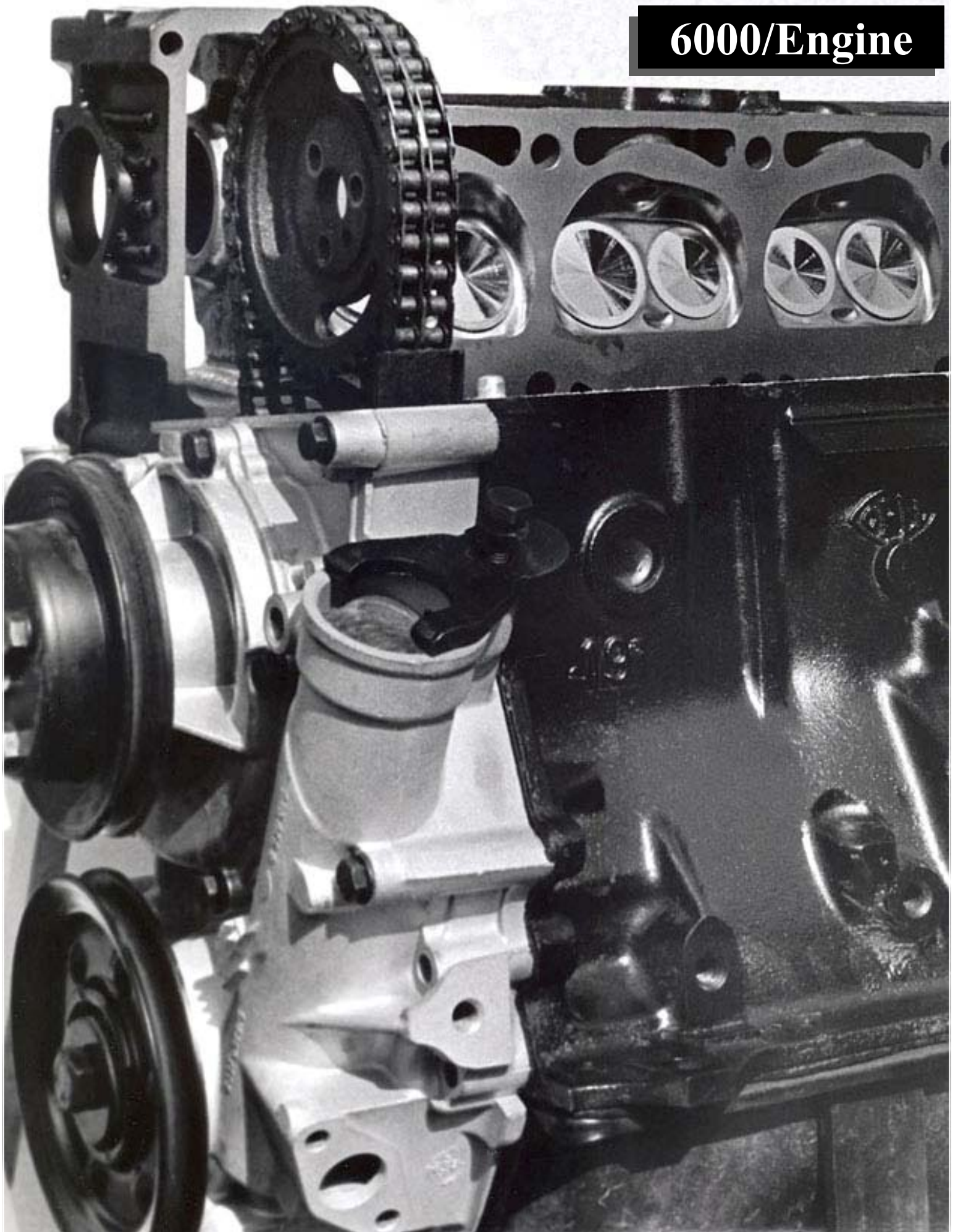



Opel GT Source is your full-line engine parts retailer. We offer more new engine parts for maintenance or engine upgrade projects.

This can range from simple re-gasketing (to help deal with a common type of oil leak) to the popular 2.0L “big valve” performance upgrade (from the original 1.9L).

*The engine is the “soul” of the car, and we have noticed the happiest owners are those who keep their cars all-Opel!*

The GT was originally designed with a high-HP “crossflow” engine, but GM’s later de-tuned actual production engines, to satisfy emissions and other export requirements.

*You can restore your GT’s lost power to the high-performance it was originally built for, using parts provided by Opel GT Source.*



**Pistons, valves & camshafts  
For popular 2.0L upgrade**

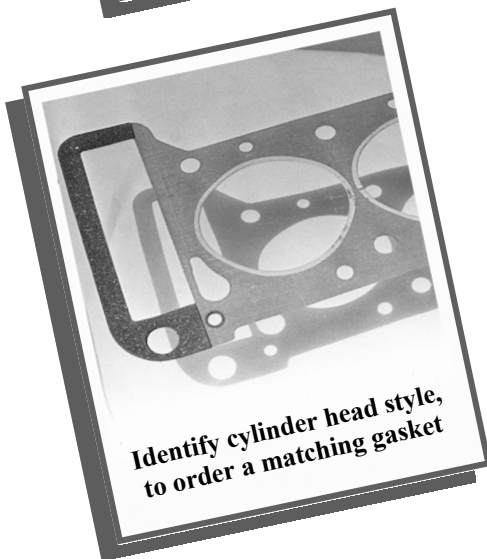

**Identify cylinder head style,  
to order a matching gasket**

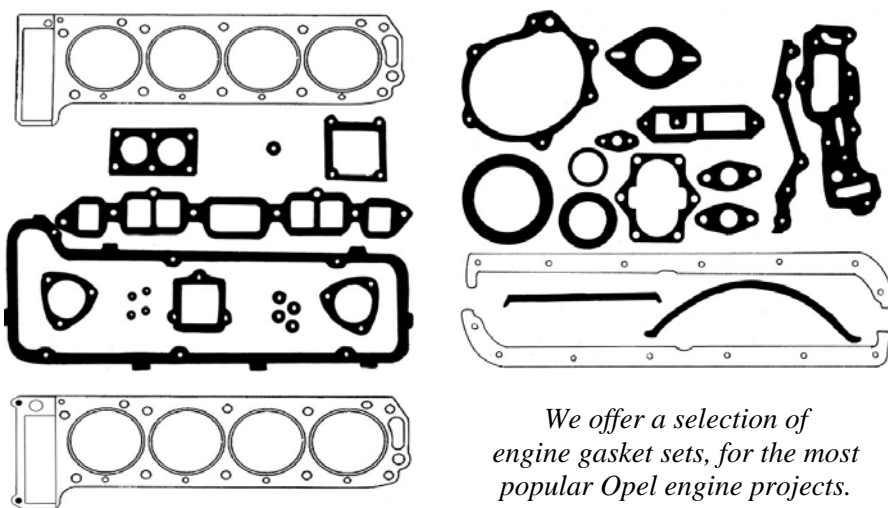

*We offer a selection of engine gasket sets, for the most popular Opel engine projects.*

### Engine Gasket Sets

#### 6002 COMPLETE GASKET SET

1968-1972, 1.9L with 10 bolt head gasket.

*Note: 2.0L head gasket can be substituted (at cost)*

#### 6003 COMPLETE GASKET SET

1973-1975, 1.9L with twelve (12) bolt head gasket.

*Note: 2.0L head gasket can be substituted (at cost)*

#### 6004 HEAD GASKET SET

1968-1972, 1.9L with 10 bolt head gasket.

#### 6005 HEAD GASKET SET

1973-1975, 1.9L with twelve (12) bolt head gasket.

#### 6070 BOTTOM END GASKET SET

Includes oil pan gaskets, timing cover gaskets, front and rear main seals, fuel pump gaskets and spacer, water pump gasket, oil pick-up gasket, distributor gasket and oil pump gasket.

### Related Items

#### 9004 GASKET: CARB TO INTAKE MANIFOLD

Special thick gasket reinforced with plastic eyes to prevent carburetor base plate warping.

Helps reduce vacuum leaks at this critical junction.

*NOTE: You will also need 9018 if your engine is equipped with a heat shield under the carburetor.*

#### 9018 GASKET: HEAT SHIELD TO INTAKE

Carburetor heat shield to intake manifold, thin.

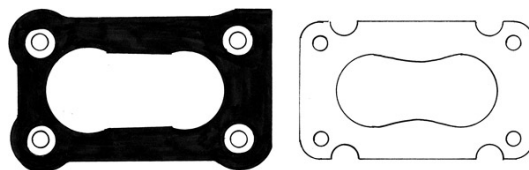

#### 12013 8mm SERRATED TOOL

Fits some engine bolts. *Offered as a convenience item.*

#### 12015 12mm SERRATED TOOL

Fits some engine bolts. *Offered as a convenience item.*

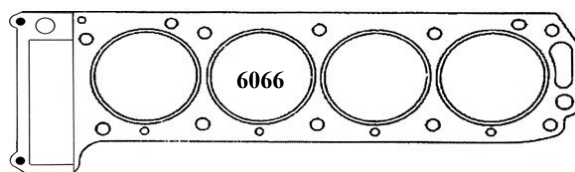
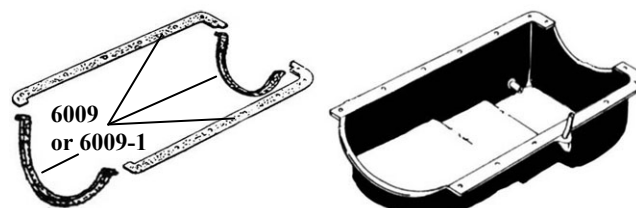
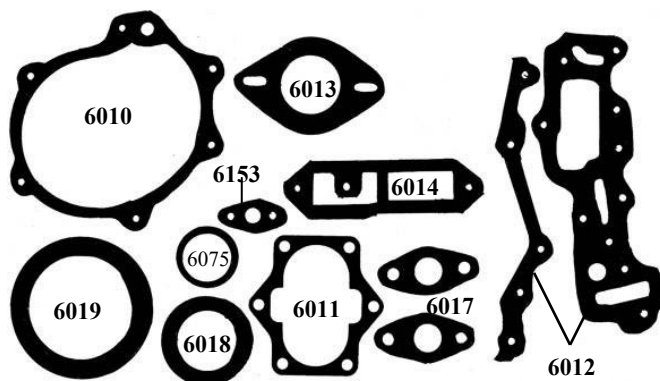
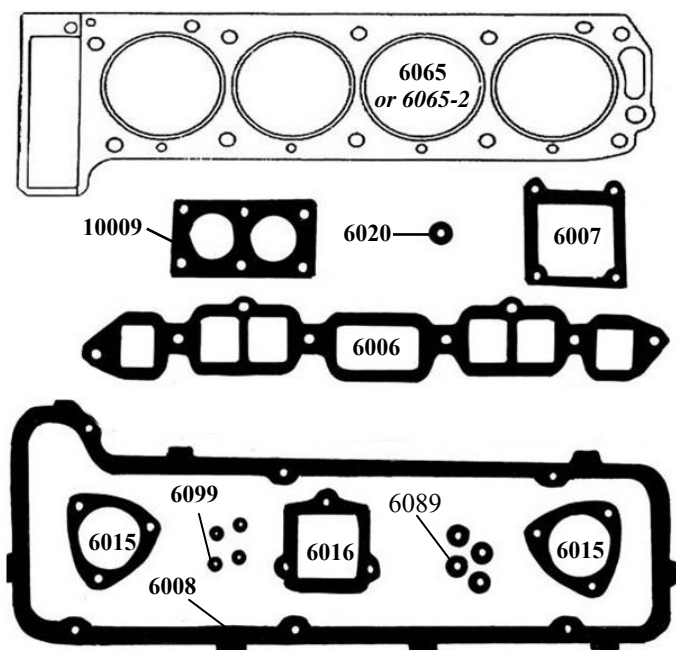

## Individual Gaskets & Seals

### 6006 INTAKE/EXHAUST GASKET

New design. Intake/exhaust to cylinder head, 1.9L

### 6007 EXHAUST TO INTAKE GASKET

Between intake & exhaust manifolds (hot spot gasket)

### 6008 VALVE COVER GASKET

Valve cover to the cylinder head. *Specify year if other than GT 1900 with aluminum valve cover.*

### 6009 OIL PAN GASKET

Oil pan to block, includes cork and rubber strips. Recommended for early-style original aluminum oil pans, also fits later-style original steel oil pans.

### 6009-1 OIL PAN GASKET, ONE-PIECE DESIGN

Upgraded 1-piece design for improved oil pan sealing.

### 6010 WATER PUMP GASKET

### 6011 OIL PUMP GASKET

Oil pump cover to timing cover

### 6012 TIMING COVER GASKETS

Timing cover to block.

### 6013 THERMOSTAT GASKET

Fits around thermostat.

### 6014 THERMOSTAT HOUSING GASKET

Thermostat housing to cylinder head.

### 6015 CAM COVER GASKET

Cam cover to head. Front or rear. Triangular shaped.

### 6016 HEAD SIDE PLATE GASKET, SQUARE

### 6017 FUEL PUMP GASKET

Fuel pump to timing cover. Two (2) required

### 6018 FRONT SEAL

Timing cover to pulley.

### 6019 REAR MAIN SEAL

Seals crankshaft rear

### 6020 O-RING SEAL

Timing cover to head, rubber.

### 6065 HEAD GASKET

Fits 1968-1972 10-bolt engines with 1.9 pistons

### 6065-2 HEAD GASKET

Fits 1968-1972 10-bolt engines with 2.0 pistons

### 6066 HEAD GASKET

1973-1975, 1.9L for twelve (12) bolt head.

### 6068 HEAD GASKET

1976-1989, 2.0L. Twelve (12) bolt. Can be adapted for use with early-style head.

### 6075 DISTRIBUTOR GASKET

Between timing cover and distributor.

### 6089 INTAKE VALVE SEAL

Special performance cup type valve seal intake valve. Four (4) required, original style for 1971-1975 valves.

### 6099 O-RING VALVE SEAL

Specify Exhaust Valve application

### 6153 GASKET, OIL PICKUP TUBE

### 6156 VALVE STEM SEAL KIT

Set of 8 valve seals for 1.9 cylinder head

### 10009 GASKET, EXHAUST FLANGE TO HEAD PIPE

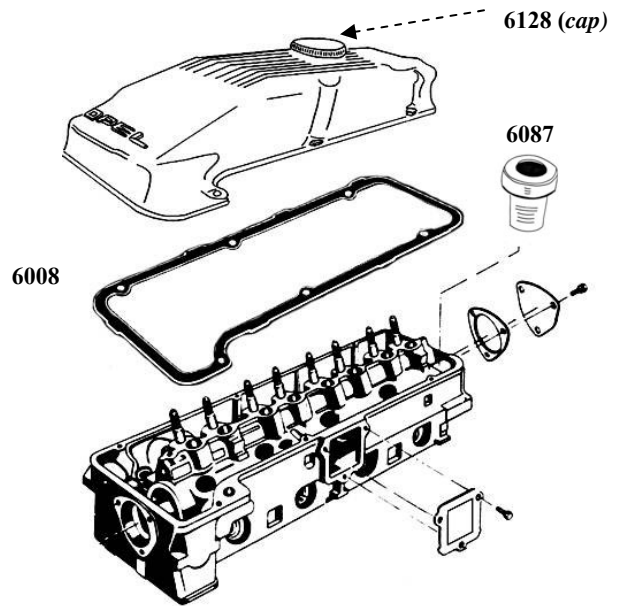

### Cylinder Head Parts

#### 6008 VALVE COVER GASKET

Valve cover to the cylinder head. *Specify model & year (if other than GT 1900 with aluminum valve cover).*

#### 6015 CAM COVER GASKET

Cam cover to head. Front or rear. Triangular shaped.

#### 6016 HEAD SIDE PLATE GASKET

Side plate to head. Square shaped.

#### 6084 PLUG

Lifter galley in cylinder head. 7mm. Four (4) required.

#### 6087 OIL DAM

Mounts in oil return hole in back of cylinder head. Increases oil bath level in head and better lubricates your vulnerable camshaft. Helps reduce cam to lifter wear. Recommended addition for all 1.9L-2.4L heads, and a must for performance engine builds/upgrades.

#### 6126 HOSE

Valve Cover large port to Weber Air Cleaner #9003

#### 6128 VALVE COVER CAP

New polished original. Also available aftermarket 12031

#### 6334T HEAD BOLT SET (TORQUE-TO-YIELD)

Availability and fitment of head bolt styles is variable. Contact OGTS to discuss options for your application.

### Head & Rocker Hardware

#### 6029 ROCKER NUT

New original. Eight (8) required.

#### 6030 ROCKER ARM

New original. Eight (8) required.

#### 6031 ROCKER STUD

New production. Eight (8) required.

#### 6073 ROCKER ARM BEARING

#### 6048 BOLT

Bolts intake/exhaust manifold to cylinder head. 6 req.

#### 6048A BOLT

Bolts intake/exhaust manifold to cylinder head. Allen Head Socket style, 9mm x 1.25 threads. Features original-style thick washer, makes tightening or removing original or special manifolds much easier. 6 required per cylinder head.

#### 6048S INTAKE/EXHAUST MANIFOLD STUD

Special Order custom-cut stud, for unique applications

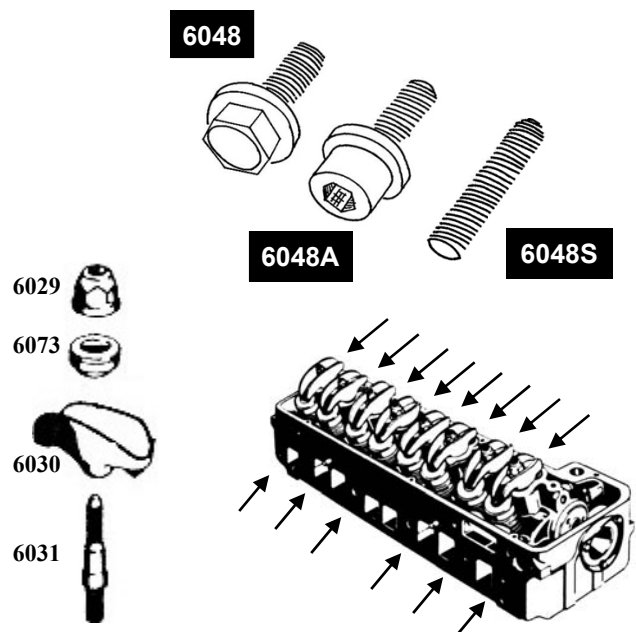





### Valves

#### 6062 VALVE, INTAKE

Stock 39mm, ~9.0mm stem diameter.  
Specify "early" or "later" style.

#### 6063 VALVE, EXHAUST

Stock 33 mm, ~9.0mm stem diameter.  
Specify "early" or "later" style.



### Valve Hardware

#### 6064 VALVE KEEPERS

Set of eight (8). Fits "Later" style valves.

#### 6089 INTAKE VALVE SEAL

Special performance cup type valve seal intake valve.  
Four (4) required, original style for 1971-1975 valves.

#### 6099 O-RING VALVE SEAL

Specify Exhaust Valve application

#### 6156 VALVE STEM SEAL KIT

Set of 8 valve seals for 1.9 cylinder head

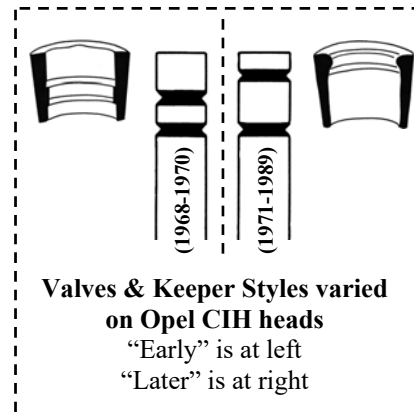
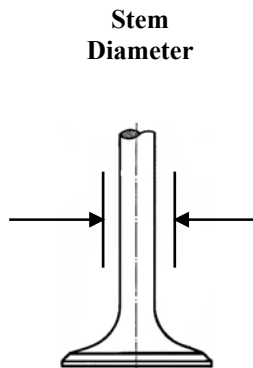

### Valve Sets

#### VKIT1.9 SET OF VALVES

Set of 8 valves, 4x Intake & 4x Exhaust for 1.9L engine  
Specify STD valve stem (or .075mmOS or .15mmOS)

#### VKIT2.0 SET OF VALVES

Set of 8 valves, 4x Intake & 4x Exhaust for 2.0L engine  
Commonly installed for performance upgrade in 1.9L  
Specify STD valve stem (or .075mmOS or .15mmOS)

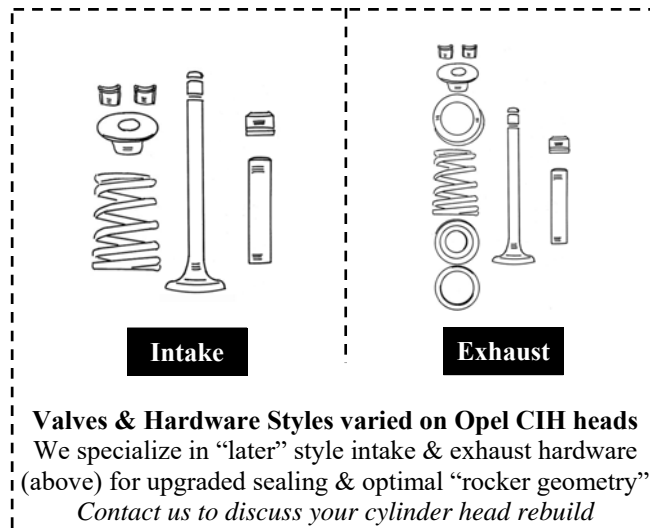

#### 6543 VALVE SPRING

Specify intake or exhaust. Best for stock cam profile.

#### 6400 HP VALVE SPRING KIT

Dual Valve Springs & Hardware for HP applications

#### 6203 VALVE GUIDE, INTAKE STD

Provides tighter valve stem clearance for intake valve  
(when original cylinder heads have excessive wear).

#### 6204 VALVE GUIDE, EXHAUST STD

Provides tighter valve stem clearance for exhaust valve

#### 6205 VALVE SEAT SET, 1.9L EXHAUST

Replacement recommended when cyl head is rebuilt

#### 6206 VALVE SEAT SET, 2.0L EXHAUST

Required for 1.9L cyl head upgrades using 2.0L valves



**Our Cams use only all-new materials, for best quality**

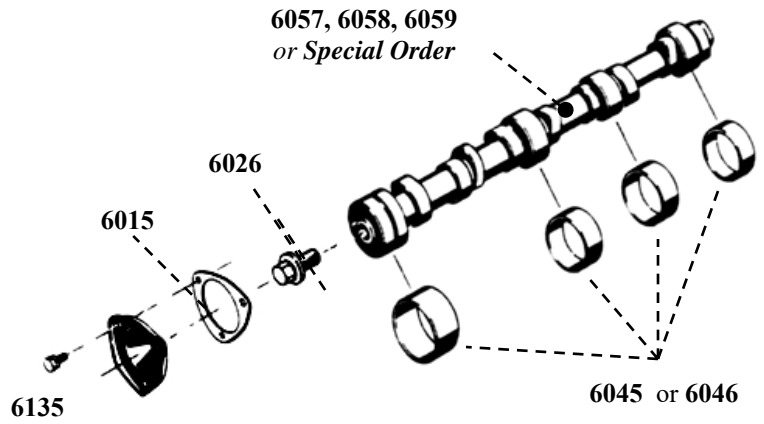

Camshaft Profiles: Camshafts achieve output by improving Opel engine breathing at the valves.

*To assure valve clearance and optimal performance, we recommend only installing camshafts that have dimensions provided for lift and duration.*

<b>Part #6057</b> ~390 Lift/~244° Duration	<b>Part #6059</b> .430" Lift/268° Duration
<b>Part #6058</b> .407" Lift/256° Duration	<b>Special Orders</b> Contact us for others

### Camshafts

**6057 CAMSHAFT**  
Stock profile, 4 bearing. 1971-74, hydraulic grind, 1.9L.

**6058 CAMSHAFT**  
HP "Torquer" .407" lift, 256 duration. Specify solid or hydraulic grind. 1.9L-2.4L. Good for street application.

**6059 CAMSHAFT**  
HP "Combination" .430" lift, 268 duration, solid or hydraulic grind. Improves street performance.

**RACING CAMSHAFTS & OTHER CAMSHAFTS**  
Additional profiles can be special-ordered.  
**Contact Opel GT Source for details.**

### Camshaft Related Parts

**6026 CAM BUTTON, NYLON**  
1973-1975 length (Can be modified to fit 1968-1972)

**6028 HYDRAULIC LIFTER**  
New. Must be replaced when installing new hydraulic-grind style camshaft. Eight (8) required per head.

**6121 SOLID LIFTER**  
New aftermarket. Must be replaced when installing new solid-grind style camshaft. Eight (8) req. per head

**6045 CAM BEARINGS**  
Set of four (4) bearings. 1971-1975, 1.9 heads, finished.

**6045-3 CAM BEARINGS**  
Three (3) bearings 1969-1970 "Delta" 1.9 head, finished

**6046 CAM BEARINGS**  
Set of three (3) bearings for non-Delta 1968-1969 head.  
Note: May require align-boring to install

**6087 OIL DAM**  
Mounts in oil return hole in back of cylinder head. Increases camshaft oil bath level. Helps reduce cam to lifter wear. *Special shoulder-topped design for an easier and more secure installation.* Recommended addition for all 1.9L-2.4L engines.

**6100T CAM BOLT (TORX)**  
Camshaft to upper timing gear attaching bolt 1.9L-2.4L. Three (3) required. New repro, Torx design.

**6135 SCREW WITH WASHER, CAM COVER**

**6170 ENGINE BREAK-IN ADDITIVE**  
12-ounce bottle of Engine Break-In Oil Additive. Use anytime you replace a cam, lifters or rebuild an engine.

**6171 ZDDP PLUS**  
4-ounce bottle of ZDDP Plus oil additive. Use every time you change your engine oil.



Opel GT Source offers a selection of piston dimensions

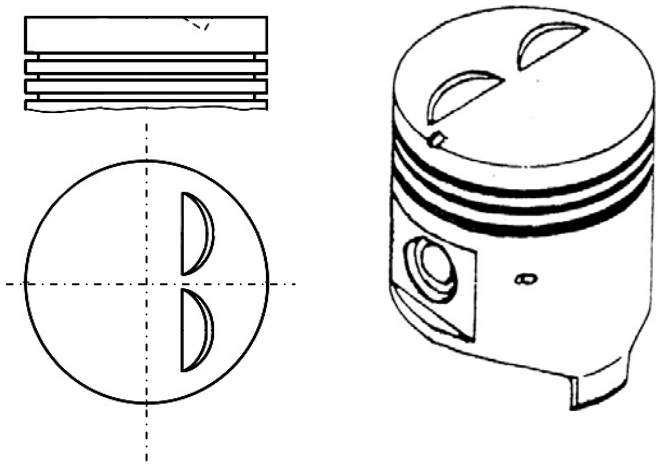

Cast-style design pistons for street-driven Opels

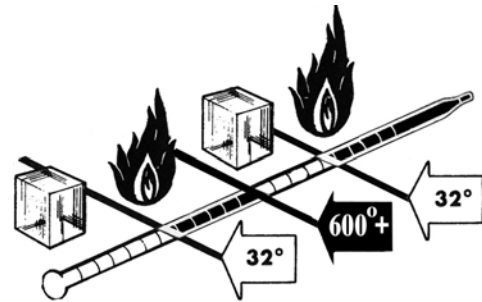

Frequent "heat cycling" is demanded from Commuter-car engines, which is why the Opel factory recommended "autothermic" (cast-style) pistons for installation in their street-driven motors.

We offer higher-quality "hypereutectic" pistons designed to handle the higher 6000RPM redline of Opel engines.

(Forged pistons can also be special-ordered for race motors)

## Pistons

### 6052.5 (~93.50mm)

1.9L 9.0 : 1 Compression Pistons, with rings and pin.  
~0.50mm (~.020") Oversized. 4 required per engine.

### 6052.75 (~93.75mm)

1.9L 9.0 : 1 Compression Pistons, with rings and pin.  
~0.75mm (~.030") Oversized. 4 required per engine.

### 60521.0 (~94.00mm)

1.9L 9.0 : 1 Compression Pistons, with rings and pin.  
1~.0mm (~.040") Oversized. 4 required per engine.

### 6132 (~95.00mm)

2.0L Pistons, with rings and pins.  
You can build your 1.9L into a 2.0L using these pistons, which will give you 9.4:1 compression with a standard 1.9L cylinder head. 4 required per engine.

### 6132M (~95.00mm)

German Mahle brand 2.0L Pistons w/rings & pins.

### SPECIAL ORDERS (SCCA/ITB CLASS-LEGAL)

Forged pistons (for racing motors using 100+ octane racing fuel), or for other sizes: Contact us for details.

**Piston Diameters:** We offer a range of Opel pistons of higher factory-rated 9.0:1 ratio in various oversizes. As dimensions can vary, final machining should be based on actual measurements at the skirts. Attention should be focused on evaluation of ring lands, as a known wear pattern also occurs there.

<b>Part #6052.5</b> ~93.50mm diameter	<b>Part #60521.0</b> ~94.00mm diameter
<b>Part #6052.75</b> ~93.75mm diameter	<b>Part #6132</b> ~95.00mm diameter



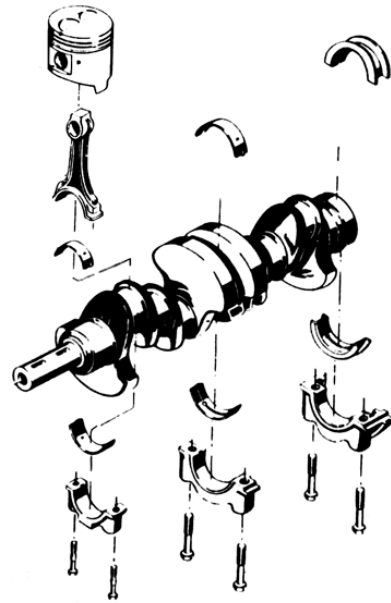

### Engine Bearings

#### 6054 ROD BEARINGS

Rod Bearing set for 1.5L, 1.9L, 2.0L, & 2.2L  
Specify the size you need at time of your order.  
Stocked sizes: Standard, 0.25mm (0.010"), 0.50mm (.020"), 0.75mm (0.030"), 1.0mm (0.040") & 1.25mm (0.050") Oversized.

### Engine Bearings

#### 6055 MAIN BEARINGS

Main Bearing set for 1.5L, 1.9L, 2.0L, 2.2L & 2.4L  
Specify the size you need at time of your order.  
Stocked sizes: Standard, 0.25mm (0.010"), 0.50mm (.020"), 0.75mm (0.030") & 1.0mm (0.040") OS.

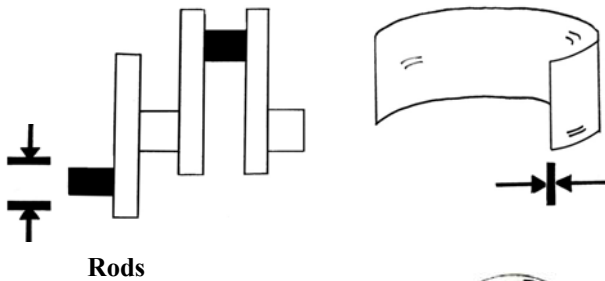

Rods

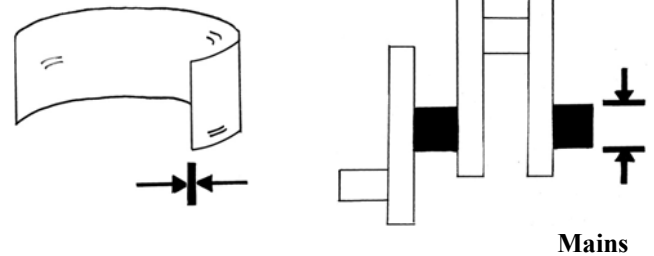

Mains

<b>Part #6054-STD</b> STD Dimension
<b>Part #6054-.025</b> .25mm (.010") <i>Oversize</i>
<b>Part #6054-.050</b> .50mm (.020") <i>Oversize</i>
<b>Part #6054-.075</b> .75mm (.030") <i>Oversize</i>
<b>Part #6054-1.00</b> 1.00mm (.040") <i>Oversize</i>
<b>Part #6054-1.25</b> 1.25mm (.050") <i>Oversize</i>

Rod Bearings are offered in sets of 4 pairs.

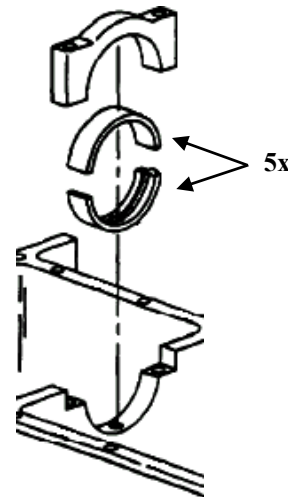
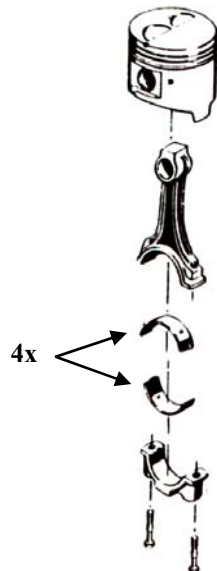

<b>Part #6055-STD</b> STD Dimension
<b>Part #6055-.025</b> .25mm (.010") <i>Oversize</i>
<b>Part #6055-.050</b> .50mm (.020") <i>Oversize</i>
<b>Part #6055-.075</b> .75mm (.030") <i>Oversize</i>
<b>Part #6055-1.00</b> 1.00mm (.040") <i>Oversize</i>

Main Bearings are offered in sets of 5 pairs, Including 4 main bearings and one thrust bearing

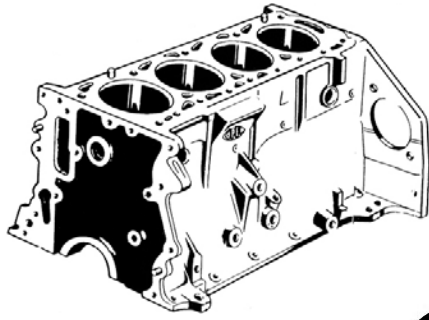

6123

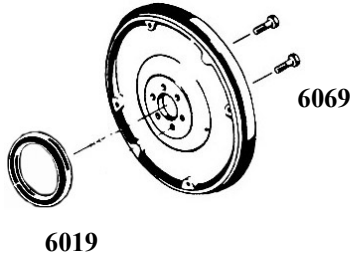

Piston Ring Sets:

You can specify the dimensions you want from an available range of ring sets that we stock.

<b>Part #6053</b> Specify: <i>STD Size</i>	<b>Part #6053</b> Specify: <i>.75mm (.030")</i>
<b>Part #6053</b> Specify: <i>.50mm (.020")</i>	<b>Part #6053</b> Specify: <i>1.0mm (.040")</i>

**Engine Block and Related Parts**

**6053 1.9L PISTON RINGS, 93mm**  
1.9L Piston Rings, set of four (4).  
Available sizes: Standard, 0.020" (.50mm), 0.030" (.75mm) & 0.040 (1.0mm).

**6019 SEAL, REAR MAIN.**  
Seals crankshaft rear

**6067 BOLT, CONNECTING ROD 1.9L**

**6069 BOLT, FLYWHEEL TO CRANK**  
1.9L-2.2L. Attaching bolts. Six (6) required.

**6085 DOWEL PIN**  
Block to head alignment.

**6123 FREEZE PLUG**  
Steel 1.5L-1.9L. Set of 4.

**Opel 1900cc Engine**

The 1900cc CIH (Cam in head) style engine was originally installed in export vehicles such as the Opel GT (1968-1973), the Opel Manta A (1970-1975), the Ascona A (1970-1975) and the Opel Kadett B (1968-1972).\*\*

This engine can be identified by a number, which is located on the driver's side of the engine block and starts with the designation "1.9" This is followed by a seven digit serial number, which can be used to identify an engine's approximate date of manufacture.

*Unlike other vehicles, Opel's engine numbers are not specific to their chassis.*

*\*\*Other vehicles were equipped with Opel CIH style 1900cc engines, include models sold in Europe such as the Ascona B, Kadett C, Manta B, the Olympia A, and several versions of the Opel Rekord, B, C, D & E.*

*The Opel CIH style engines were upscaled to 1979cc, 2197cc and 2394cc and installed in later Opel vehicles such as the Omega.*



**6000 RPM "Redline"**  
We offer higher-quality "hypereutectic" cast pistons to handle higher-rpm demands

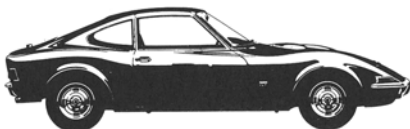

**Timing Cover  
Exterior View**

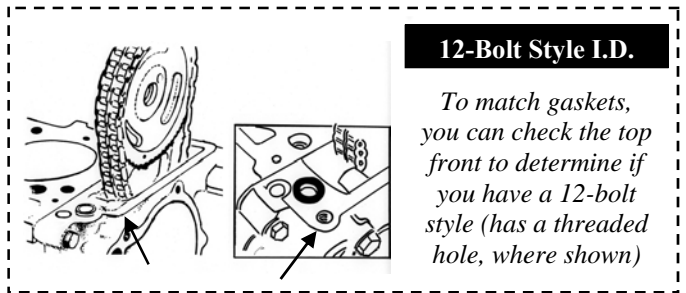
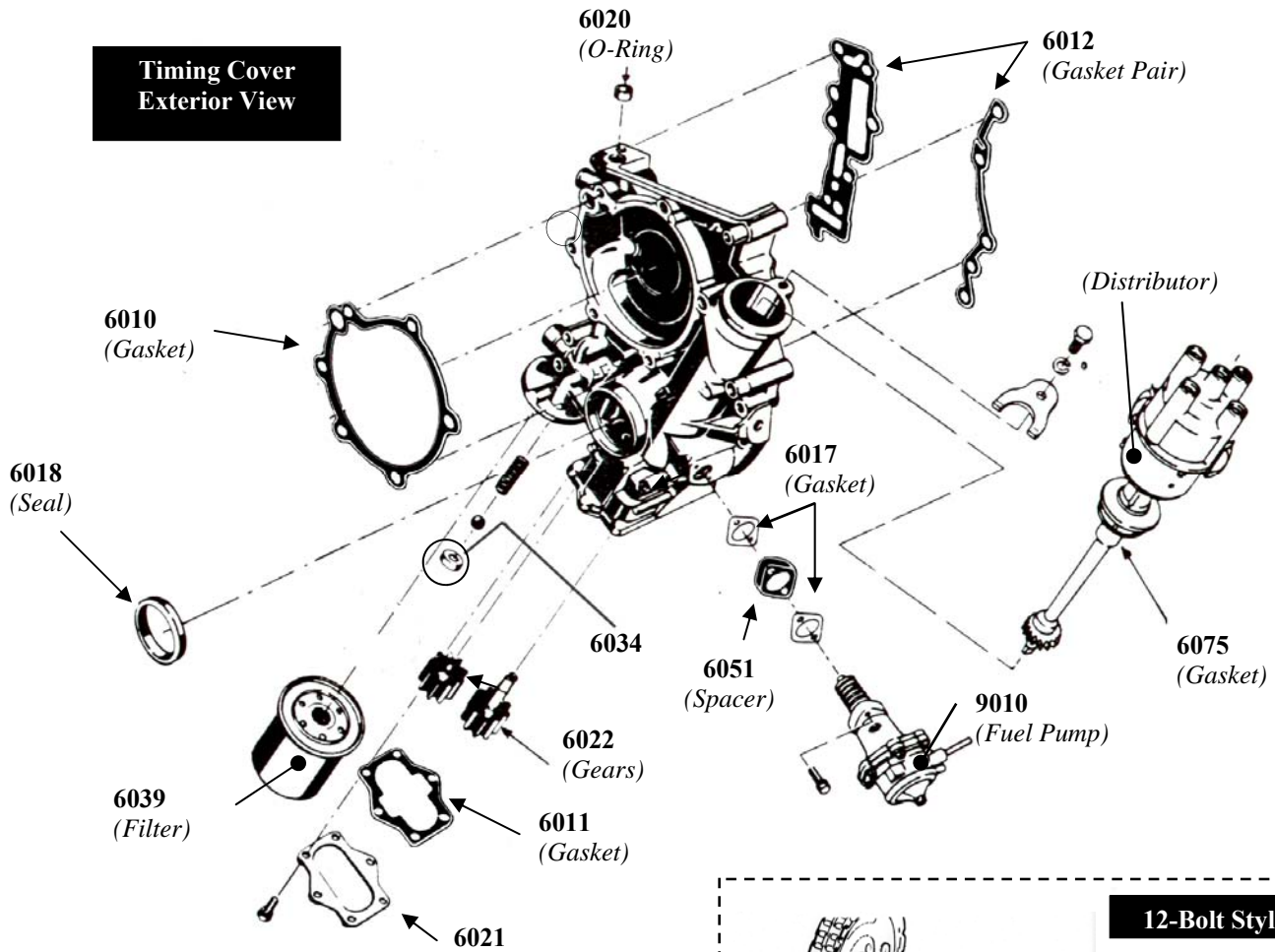

**Timing Cover Related Parts**

**6010 WATER PUMP GASKET**  
Water pump to timing cover.

**6011 OIL PUMP GASKET**  
Oil pump cover to timing cover.

**6012 TIMING COVER GASKETS**  
Timing cover to block.

**6017 FUEL PUMP GASKET**  
Fuel pump to timing cover. Two (2) required.

**6018 FRONT SEAL**  
Timing cover to pulley.

**6020 O-RING SEAL**  
Timing cover to head, rubber.

**6021 OIL PUMP COVER WITH GASKET**  
Improved design features newly-calibrated relief valve. This sometimes cures low oil pressure problems without having to replace costly gears. 1.9L-2.4L.

**6022 OIL PUMP KIT**  
Oil pump gears & special relief-valve style cover plate.

**6034 CUP**  
Oil pressure by-pass in oil filter area of timing cover.

**6051 FUEL PUMP SPACER**  
Spacer for between fuel pump and timing cover.

**6075 DISTRIBUTOR GASKET**  
Between timing cover and distributor.

**6075 TIMING COVER GASKET SET**  
Includes pair of timing cover gaskets and front seal

**6150 HEAD TO TIMING COVER BOLT**  
Bolt from front cylinder head to timing cover, 1972-1994. Two (2) required.

**6167 TIMING COVER BOLT SET**  
Set of new bolts helps better attach timing cover to front of engine block.

**6168 BOLT SET FOR WATER PUMP**  
Set of 6 new water pump to timing cover bolts



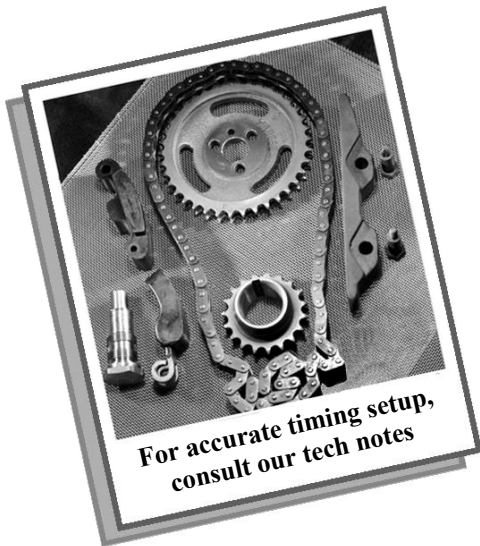

For accurate timing setup,  
consult our tech notes

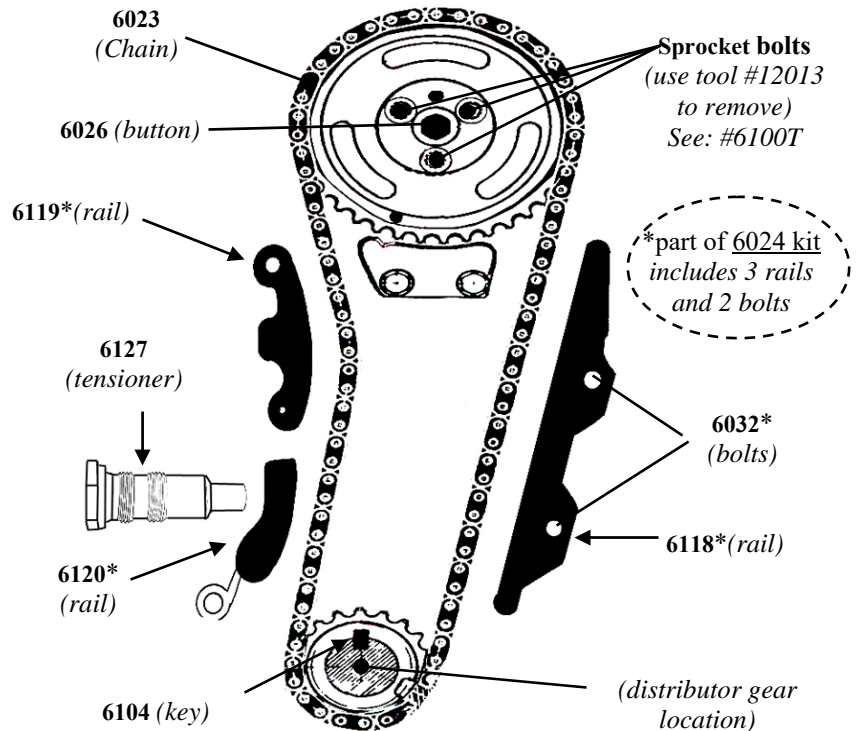

### Timing Chain Hardware



6032 (Set of 2,  
special timing rail bolts)

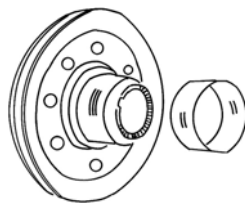

6131 Front Pulley Repair Sleeve  
(Does not include front pulley itself)

### Timing Chain & Related Parts

#### 6023 TIMING CHAIN

Choose from open or closed-link design. 1.9L-2.4L.

#### 6025 CAM BUTTON, NYLON

1968-1972 10-bolt head length. *Inquire for availability*

#### 6026 CAM BUTTON, NYLON

1973-1975 12-bolt length (Can modify to fit 1968-1972)

#### 6100T CAM BOLT (TORX)

Camshaft to upper timing gear attaching bolt  
1.9L-2.4L. Three (3) required. New repro, Torx design.

#### 6104 KEY WAY

On front crankshaft for front pulley and timing gears.

#### 6130 DISTRIBUTOR DRIVE GEAR

Gear on crankshaft, brass. *Inquire for availability.*

#### 6131 FRONT PULLEY SLEEVE REPAIR KIT

Helps prevent oil leaks cause by a grooved pulley shaft

#### 6105 TIMING CHAIN GEAR SET

Contact us to inquire. Subject to availability.

#### 6024 TENSIONER KIT

Harder-compound rubber design for better durability. Kit includes right and left timing chain guides, tensioner guide rail, and special hardware, 1.9L-2.4L.

#### 6118 TIMING CHAIN RAIL

New Opel Design Long timing chain rail with hardware. Reduces timing chain rattling. Fits: All CIH Opel engines. 1.5L, 1.9L, 2.0L, 2.2L & 2.4L CIH.

#### 6119 TIMING CHAIN RAIL, SHORT UPPER

New Opel Design Short Upper timing chain rail. All-rubber, reduces the common timing chain rattle. Fits: All CIH Opel engines:  
1.5L, 1.9L, 2.0L, 2.2L & 2.4L CIH.

#### 6120 TENSIONER ARM

Lower tensioner arm for the timing chain. Common wear item. Fits: All CIH Engines.  
1.5L, 1.9L, 2.0L, 2.2L & 2.4L CIH.

#### 6127 HYDRAULIC TENSIONER

Hydraulic Tensioner, Fits: All CIH Engines.  
1.5L, 1.9L, 2.0L, 2.2L & 2.4L CIH.

#### 6032 SPECIAL BOLTS/LONG TIMING CHAIN RAIL

Set of 2. (Already included in #6024 timing rail kit)

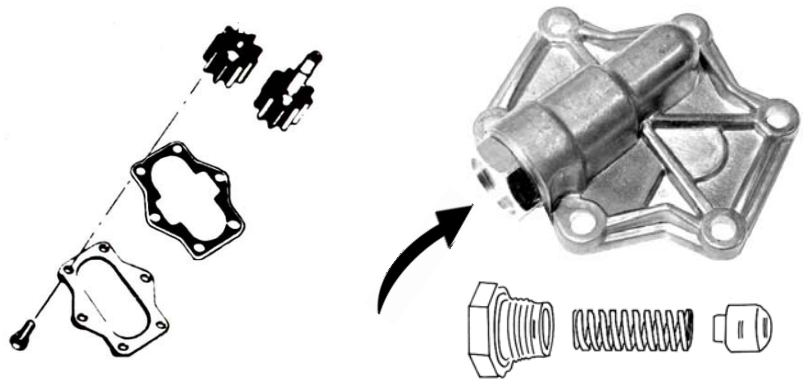

*Opel GT Source offers "improved design" oil pump cover plates, which includes a relief valve circuit. (This was a critical factory upgrade, intended to help ensure more consistent oil pressure,, as it relocated the function from the problematic upper timing cover).*

### Engine Oiling System Parts

#### 6021 OIL PUMP COVER WITH GASKET

This generally cures low oil pressure problems without having to replace costly gears. New production item, includes critical metal pressure relief valve, with an upgraded calibration for maximum 3.5psi. Fits all Opel CIH engines 1.9L, 2.0L, 2.2L, 2.4L.

#### 6011 OIL PUMP GASKET

Oil pump cover to timing cover.

#### 6087 OIL DAM

Mounts in oil return hole in back of cylinder head. Increases camshaft oil bath level. Helps reduce cam to lifter wear. Special shoulder-topped design for an easier and more secure installation. Recommended addition for all 1.9L-2.4L.

#### 6022 OIL PUMP KIT

Oil pump gears and cover plate. Inquire for availability.

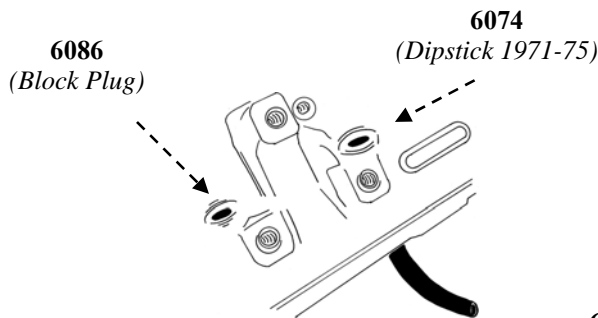

6074 or 6074A

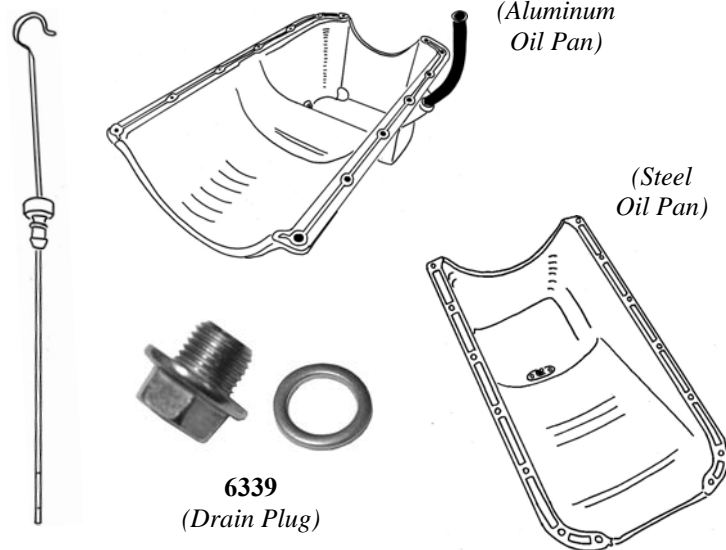

### Oil Pan and Related Parts

#### 6009 OIL PAN GASKET

Oil pan to block, includes cork and rubber strips.

#### 6009-1 OIL PAN GASKET, ONE-PIECE DESIGN

Upgraded 1-piece design for improved oil pan sealing. Recommended with steel oil pan for optimal fitment.

#### 6074 DIP STICK

New. Late 1971-1975 with steel oil pan only. 1.9L-2.4L.

#### 6074A DIP STICK

New. 1968-1971 GT with aluminum oil pan only. 1.9L

#### 6086 PLUG

13mm dipstick hole, lower driver's side of engine block

#### 6153 GASKET, OIL PICKUP TUBE

#### 6160 DIPSTICK RUBBER PLUG

Fits 1968-1971 GT dipsticks with aluminum oil pan

#### 6339 OIL DRAIN PLUG

Includes sealing washer



### Engine Filters and Lubricants

#### 6039 OIL FILTER

High quality oil filter

#### 6039KN K&N OIL FILTER

Higher-Performance oil filter traps smaller particles.



6171

6170

#### 6170 COMP CAMS ENGINE BREAK-IN ADDITIVE

12-ounce bottle of Engine Break-In Oil Additive. Use anytime you replace a cam, lifters or rebuild an engine. Contains friction modifiers required during initial break-ins.

#### 6171 ZDDP PLUS

Small bottle of ZDDP oil additive. Helps prevent premature camshaft failure from reduced zinc in oils. Use every time you change your engine oil. Offered as a convenience item.

#### 12121 ENGINE BREAK-IN OIL ADDITIVE

Redline brand, 16oz bottle

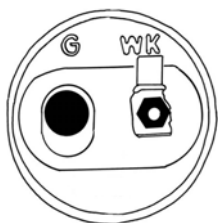

6079A (Oil Sender unit)

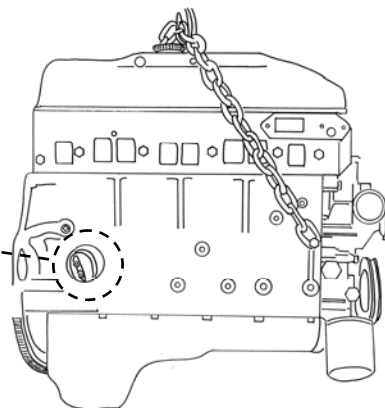

### Oil Pressure Sensors

#### 6079A OIL PRESSURE SENDER, AFTERMARKET

New production oil pressure sender. Has both gauge and warning light function. Fits all GT & Opels with Rallye pac gauges. *Metal housing as shown above, comes without rubber boot.*

#### 5052A GT OIL TEMPERATURE AND VOLTAGE GAUGE

Provides better monitoring of engine operations. Replaces the GT clock. Includes sender 5054.

#### 5054 OIL TEMPERATURE SENDING UNIT

For oil temperature gauge 5052.



5052  
(Special Order item)



#### Oil Pressure Gauge

Factory Calibration  
Each bar = ~14.7psi



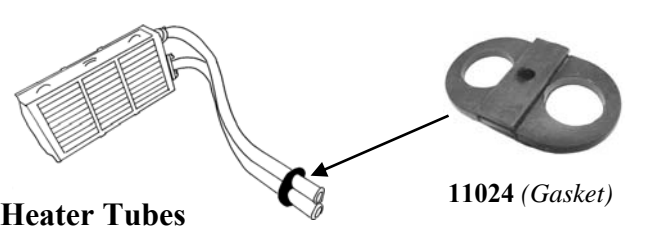
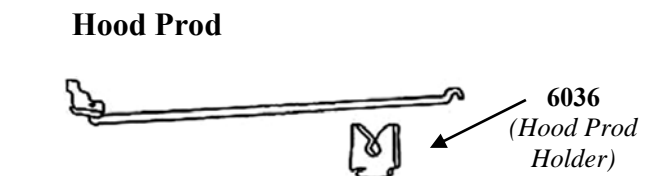
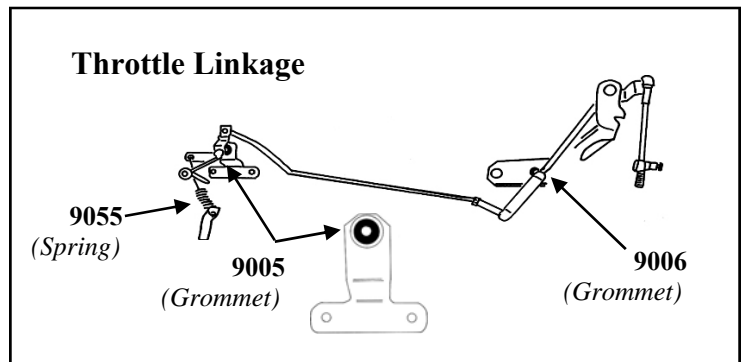
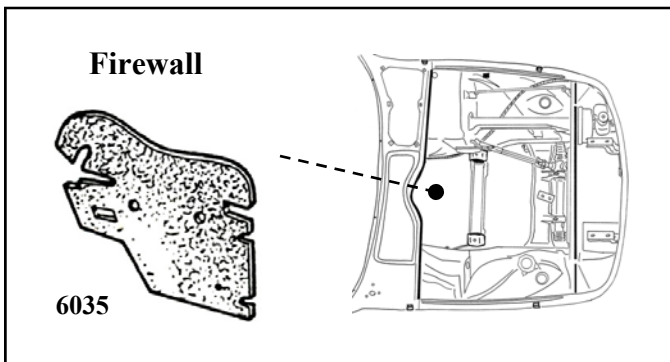
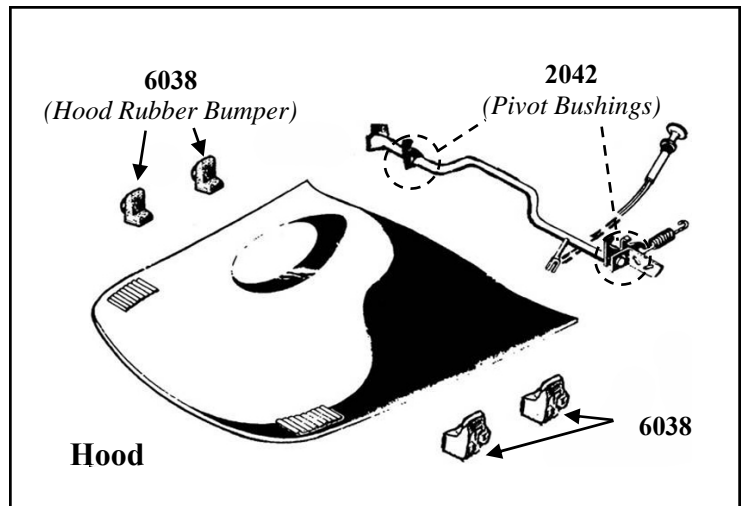
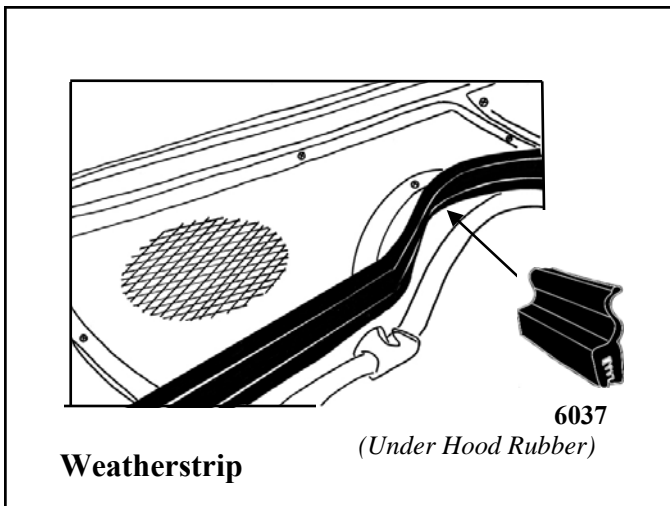

### Underhood Hardware Parts

#### 2042 BUSHINGS

GT hood latch pivots. Set of two (2).

#### 5083 GT UNDERHOOD LIGHT KIT

#### 6035 FIREWALL MATERIAL

New firewall material to replace your old, torn or missing firewall mat on your 1968-1973 Opel GT.

#### 6035R RETAINER SET, for 6035 FIREWALL MAT

Set of 3 plastic retainer plugs, used to secure the firewall mat 6035 to the firewall of the GT.

#### 6036 HOOD PROD HOLDER

Holds hood prod when hood is closed. Polyurethane replacement part.

#### 6037 UNDER-HOOD RUBBER

A sturdy design, these strips help keep engine fumes from entering the cars interior through the air vents, and also direct air flow through the radiator to help cooling. Sold as a four (4) piece set.

#### 6038 HOOD RUBBER BUMPERS

Protects car body from hood when hood is closed. Attaches to inner fender, reduces rattles. A required part of any GT repaint project. 4 per car.

#### 7001 MOTOR MOUNT

Fits GT, Right or left side. See in "Driveline" section.

#### 9005 THROTTLE GROMMET, GT

Accelerator linkage to firewall, passenger side. Improves linkage throttle response and decreases wear at throttle shaft bushing of carburetor. Polyurethane.

#### 9006 THROTTLE GROMMET, GT

Accelerator linkage to firewall, driver side. Improves linkage throttle response.

#### 9055 THROTTLE RETURN SPRING

New production. Connects linkage to tab on firewall.

#### 11024 HEATER BOX GASKET

GT heater box tubes to chassis. Rubber. Helps keep engine fumes out of car interior.



"20" and GM marks, are visible above rear alternator bracket mount

## 2.0L Opel CIH Engine (Early 1980's 12-Bolt Cylinder Head style)

Direct bolt-up replacement for the Opel 1900  
(with some modifications, including fuel pump & accessories)

More torque and horsepower than original 1.9L.  
95mm bore, 70mm stroke. Best when used  
as a drop-in replacement on a street-driven Opel.

*Special order item.*

*Subject to Availability. Contact us for more details*

### Opel 2.0L CIH Engine Parts

#### 6132 2.0L PISTONS, 95mm

2.0L STD 9.4:1 Compression Pistons, includes rings and wrist pins. Build your 1.9L into a 2.0L using these pistons. Provides 9.4:1 compression with a standard 1.9L cylinder head; Compatible w/ordinary pump fuel.  
*Optional: #6132M German Mahle brand 2.0 piston set*

#### VKIT 2.0 VALVE SET

4x Intake and 4x Exhaust Valves for 2.0L engine.  
Frequently installed to upgrade 1.9L CIH cylinder head

#### 6065-2 HEAD GASKET 2.0L

Fits 1968-1972 10-bolt engines with 2.0 pistons

#### 6068 HEAD GASKET

2.0 gasket fits 1973-1989 12-bolt Opel cyl heads.

### Opel 2.0L CIH Engine Parts

#### 6102 FRONT PULLEY BOLT 2.0L

#### 6103 FRONT PULLEY WASHER 2.0L

#### 6140 PISTON RINGS 2.0L, STD Set of 4

#### 6188 HEAD GASKET SET

1976-1991, 2.0L with twelve (12) bolt head gasket.

#### 6189 2.0 CYLINDER HEAD

Factory big valve head with 42mm intake valves and 36mm exhaust valves. Subject to availability.

#### 6200 2.0 ENGINE

Used 2.0L CIH Opel Engine. Subject to availability.

#### 6334 2.0 CYLINDER HEAD BOLT SET

Five long & five short cyl head to engine block bolts.

#### 6334T HEAD BOLT SET, 2.0L

Torque to Yield Design, uses Torx bit

#### 10016 2.0 EXHUAUST FLANGE GASKET

76mm x 113mm w/46mm ports.

#### 10019 2.0 EXHUAUST FLANGE GASKET

For English FI Exhaust Manifold.

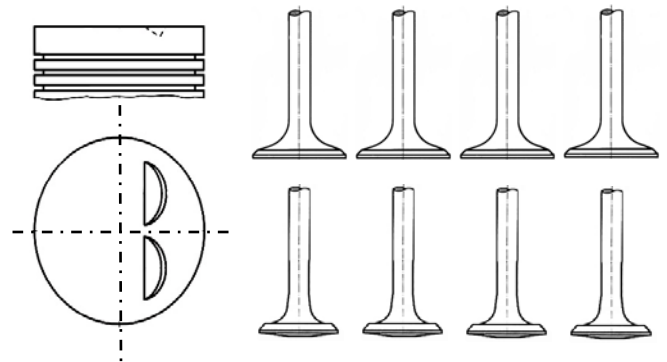

6132 or 6132M  
(95mm pistons)

VKit2.0  
(4x 42mm Intakes & 4x 37mm Exhausts)

*Consider also rebuilding your original 1.9L Opel engine using 2.0 sized pistons and valves combined with other options like a higher-lift camshaft or larger carburetor.*

*This popular combination provides power "lost" when GM redesigned export engines for reduced output.*

### Opel 2.0L CIH Engine Valves

#### 6154 VALVE 2.0L INTAKE

Individual valve

Approx. 42mm face, 9mm stem diameter (STD)

*Inquire if oversize stems required (.075mm, .15mm)*

#### 6155 VALVE 2.0L EXHAUST

Individual valve

Approx. 37mm face, 9mm stem diameter (STD)

*Inquire if oversize stems required (.075mm, .15mm)*

#### 6203 VALVE GUIDE, INTAKE STD

Restores intake valve stem clearance in worn head

#### 6204 VALVE GUIDE, EXHAUST STD

Restores exhaust valve stem clearance in worn head

#### 6206 VALVE SEAT SET, 2.0L EXHAUST

Required for 1.9L cyl head upgrades using 2.0L valves

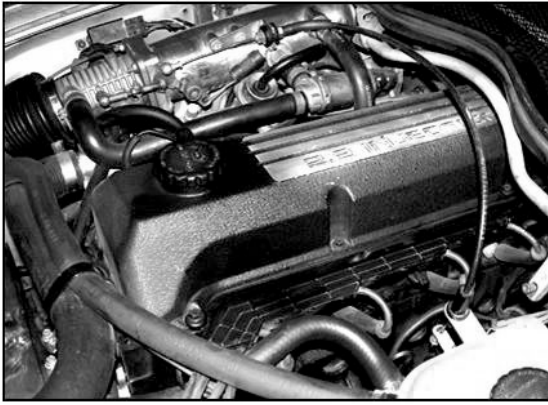

## 2.2L Opel CIH Engine (Mid-1980's 12-Bolt Cylinder Head style)

Direct bolt-up replacement for the Opel 1900  
(with some modifications, including an oil pan & accessories)

More torque and horsepower than original 1.9L or 2.0L.  
95mm bore, 77.50mm stroke. Preferred for some  
higher-revving applications.

*Special order item.*

*Subject to Availability. Contact us for more details*

### 2.2L Engine Valves

#### VKIT2.2 VALVE SET

Set of valves for 2.2L Opel engine  
(4x Intake valves and 4x Exhaust valves)

#### 2.2IN INTAKE VALVE

Intake Valve for 2.2L engine (45mm diameter face)

#### 2.2EX EXHAUST VALVE

Exhaust Valve for 2.2L engine (41mm diameter face)

#### 6203 VALVE GUIDE, INTAKE STD

Restores intake valve stem clearance in worn head

#### 6204 VALVE GUIDE, EXHAUST STD

Restores exhaust valve stem clearance in worn head

### 2.2L Engine Hardware

#### 6041-2.2 DISTRIBUTOR CAP & ROTOR, 2.2L

#### 6069 BOLT, FLYWHEEL TO CRANK

Attaching bolt for 2.2L. Six (6) required.

#### 6102 BOLT, FRONT PULLEY, 2.0L-2.4L

#### 6103 WASHER, FRONT PULLEY, 2.0L-2.4L.

#### 6142 2.2L PISTON RINGS, 95mm

2.2L, STD size. Set of four (4)

#### 6144 ALUMINUM VALVE COVER

2.2L, black with machined top surface.  
"2.2 INJECTION" on top. Limited Stock.

#### 6161 HEAD BOLT, 2.2L LONG

#### 6162 HEAD BOLT, 2.2L SHORT

#### 6334 HEAD BOLT SET, 2.2L

Allen-Head design, 5 long and 5 short

#### 6334T HEAD BOLT SET, 2.2L

Torque to Yield Design, uses Torx bit

#### 6338 SPACER

Helps fit 1.9L exhaust manifold to 2.2L head

### 2.2L Gaskets & Seals

#### 6008S VALVE COVER GSKT, 2.2L EFI VLV COVER

If you are running the 2.2L EFI aluminum valve  
cover on your 2.2L, order this gasket.

#### 6137 THERMOSTAT HOUSING GASKET, 2.2L

#### 6138 INTAKE / EXHAUST GASKET, 2.2L

#### 6139 HEADER GASKET

Made from high-temp crush-fit material.  
For 2.2L-2.4L intake/exhaust.

#### 6147 HEAD GASKET SET, 2.2L

#### 6148 FULL GASKET SET, 2.2L

#### 6156B VALVE STEM SEAL KIT, 2.2L

#### 16018 THERMOSTAT "O" RING, 2.2L

### 2.2L Recommended Hardware

#### 8080 FLYWHEEL

See Trans/Clutch section for details

#### 8081 CLUTCH KIT

See Trans/Clutch section for details

#### 9048 MANIFOLD, DUAL SIDE DRAFT 2.2L-2.4L

See Fuel section for details

#### 9065 DCOE SOFT MOUNT KIT

See Fuel section for details

#### 9063 WEBER SNORKEL "DOME" KIT

See Fuel section for details

#### 6338 ADAPTER PLATE

For install of 1.9L exhaust manifold on 2.2L

#### 11033 ADAPTER PLATE

For install of 1.9L thermostat housing to 2.4L head



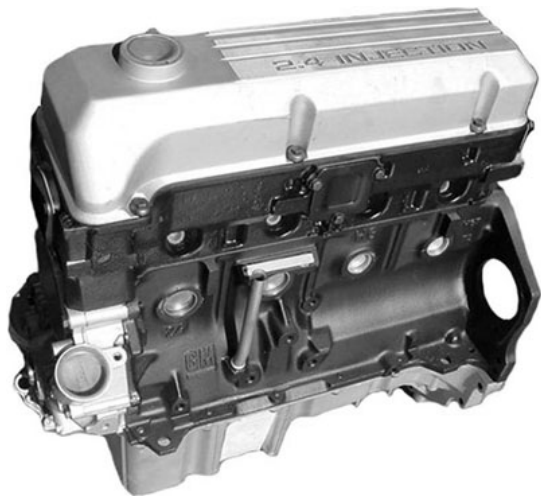

## 2.4L Opel CIH Engine (Late 1980's 12-Bolt Cylinder Head style)

Direct bolt-up replacement for the Opel 1900  
(with some modifications, including an oil pan & accessories)

Top of the line for torque and horsepower  
compared to an original 1.9L, 2.0L, or 2.2L  
95mm bore, 85mm stroke. Noted for low-end torque.

*Special order item.*

*Subject to Availability. Contact us for more details*

### 2.4L Engine Valves

#### VKIT2.4 VALVE SET

Set of valves for 2.4L Opel engine (4x Intake & 4x Exhaust)

#### 2.4IN INTAKE VALVE

Intake Valve for 2.4L engine (45mm diameter face)

#### 2.4EX EXHAUST VALVE

Exhaust Valve for 2.4L engine (41mm diameter face)

#### 6203 VALVE GUIDE, INTAKE STD

Restores intake valve stem clearance in worn head

#### 6204 VALVE GUIDE, EXHAUST STD

Restores exhaust valve stem clearance in worn head

### 2.4L Engine Hardware

#### 6054-2.4 ROD BEARINGS 2.4L

#### 6082 OIL PICKUP TUBE BRACKET, 2.4L

Specially designed to clear crank counterweight

#### 6101 FLYWHEEL BOLT, 2.4L

#### 6102 BOLT, FRONT PULLEY, 2.0L-2.4L

#### 6103 WASHER, FRONT PULLEY, 2.0L-2.4L.

#### 6159 PISTON RINGS, 95mm

2.4L,. Inquire for sizes, Set of four (4)

#### 6334 HEAD BOLT SET, 2.4L

Allen-Head design, 5 long and 5 short

#### 6334T HEAD BOLT SET, 2.4L

Torque to Yield Design, uses Torx bit

### 2.4L Gaskets & Seals

#### 6068 HEAD GASKET, 2.4L CIH 1988-1996

#### 6089 VALVE SEALS

Special performance cup-type design, set of 8

#### 6137 THERMOSTAT HOUSING GASKET, 2.4L

#### 6138 INTAKE / EXHAUST GASKET, 2.4L

#### 6139 HEADER GASKET

Made from high-temp crush-fit material.  
For 2.2L-2.4L intake/exhaust.

#### 6148-2.4 FULL GASKET SET, 2.4L

#### 6225 OIL PAN GASKET, ONE-PIECE

Fits 2.4L Aluminum oil pan

#### 6335 BOTTOM END GASKET SET, 2.4L

For 2.4L with 2.4L oil pan.

#### 6336 HEAD GASKET SET, 2.4L

#### 6424 INTAKE/EXHAUST TO HEAD 2.4L

#### 10019A EXHAUST FLANGE GASKET 2.4L

76mm x 140.5mm with 47mm ports

#### 16018 THERMOSTAT "O" RING, 2.4L

### 2.4L Recommended Hardware

#### 8080 FLYWHEEL & 8081 CLUTCH KIT

See Trans/Clutch section for additional details

#### 9048 MANIFOLD, DUAL SIDE DRAFT 2.2L-2.4L

#### 9063 WEBER SNORKEL "DOME" KIT

#### 9065 DCOE SOFT MOUNT KIT

See Fuel section for additional details

#### 11033 ADAPTER PLATE

For install of 1.9L thermostat housing to 2.4L head

#### 6338 ADAPTER PLATE

For install of 1.9L exhaust manifold on 2.2L



Brake Vacuum  
Booster Seals

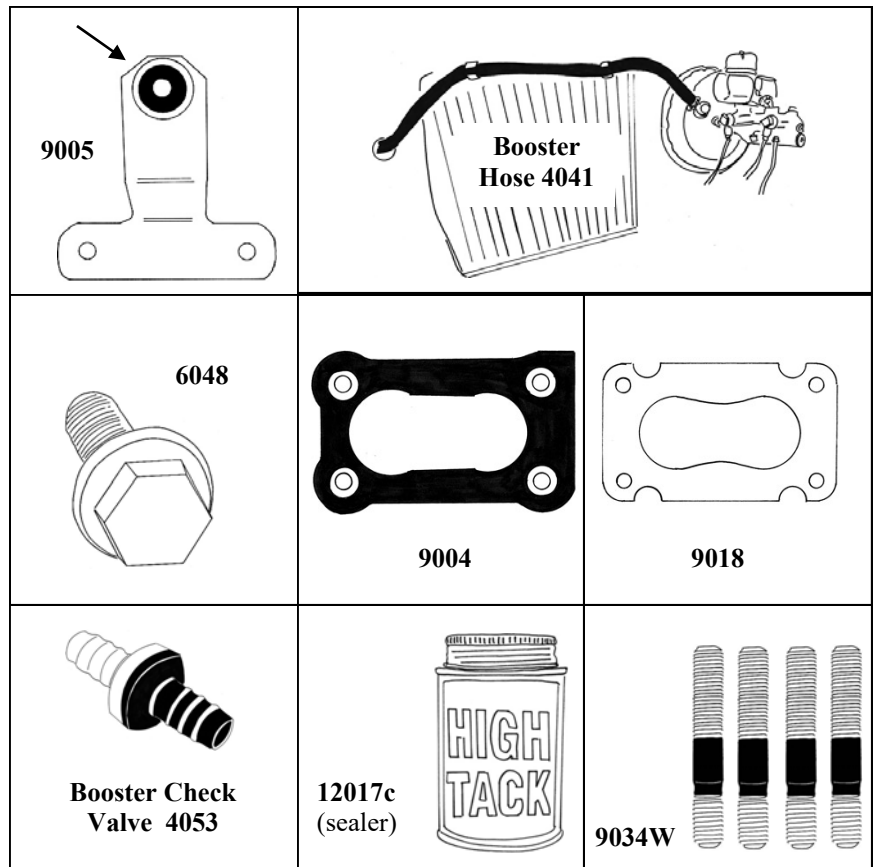
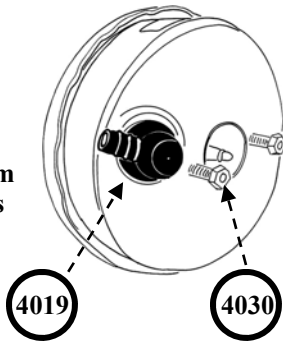

### Vacuum-System Related Parts

#### 4019 BRAKE BOOSTER HOSE INLET SEAL

Rotate the plastic elbow 90 degrees counter-clockwise to access this seal Fits original-style boosters.

#### 4030 BRAKE BOOSTER TO MASTER CYLINDER SEAL

Wear on this master cylinder "front seal" causes leaks

#### 4041 BRAKE BOOSTER HOSE

Vacuum pressure present within the brake booster circuit requires this "thick" reinforced replacement hose.

#### 4053 BRAKE BOOSTER ONE WAY CHECK VALVE

Located on the booster hose about 9" from the manifold port, this valve helps maintain vacuum to the (original-style) booster

#### 6006 INTAKE/EXHAUST MANIFOLD GASKET

New design, helps cure common vacuum leaks at head

#### 6048 INTAKE/EXHAUST MANIFOLD BOLTS

Connects Manifold to cylinder head, 6 required per car) Bolt threads (9mm/1.25) are subject to wear from vibration; Replace if worn.

#### 9004 THICK CARBURETOR MOUNT GASKET

A special 3/16" thick gasket, to seal vacuum at a critical junction & insulate the carburetor from damaging manifold heat. Helps to reduce vapor-lock in warm weather driving. Do NOT use a thin gasket here !! Use with #12017C sealer (listed below).

#### 9018 THIN CARBURETOR HEAT SHIELD GASKET (if heat shield is installed)

#### 9005 THROTTLE GROMMET, PASSENGER SIDE

Our durable polyurethane material helps reduce wear on the critical "throttle shaft bushing" of carburetor.

#### 9006 THROTTLE GROMMET, DRIVER'S SIDE

This assists pivoting of the driver's side linkage during acceleration

#### 9034W INTAKE STUD KIT

4 studs supplied in each kit  
(Specify 9034W for Weber carb, or 9034S for Solex)

#### 9070 IDLE JET O-RING

An often neglected source of a "hidden" vacuum leak.

#### 12017C GASKET SEALER

"High Tack" 4 oz can. Offered as convenience item

## Engine Notes

Opel engines require evaluation and maintenance. Many owners are also upgrading them for increased performance.

Important engine maintenance includes regasketing when oil leaks are present, or rebuilding when pistons are determined to have too much wear to provide adequate power for street driving.

### Engine evaluation

Start by verifying that any unknown engine can be rotated with a 19mm wrench. Once an engine is verified to be freely turning, then continue by checking for its identifying marks and perform a compression test to indicate its internal condition.

### Oil Pressure Readings

Another important indicator is the reading on the oil pressure gauge, particularly at warm idle and at hot idle. For optimal oil pressure, we recommend installation of a new replacement oil pump cover (with an upgraded relief valve) and use of Castrol 20/50W GTX conventional type motor oil (when suitable for driving conditions).

### Engine Upgrades

An increasingly popular project, it may be best to acquire a "spare engine" to start with, so critical machining work and component assembly can be done off the car, which simplifies tasks and minimizes vehicle downtime.

### Technical Instructions

Special tools and assembly procedures are required for Opel engines. We recommend consulting available technical instructions, including printed guides and Opel GT Source tech notes, when performing service.

*Additional tuning procedures and specifications are available within the "tips" portion of our website at [www.opelgtsource.com](http://www.opelgtsource.com)*

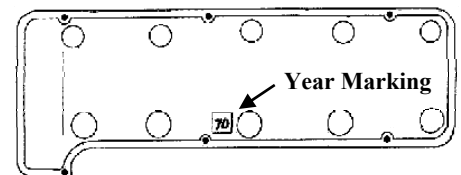
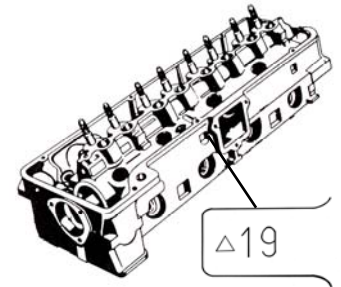

Above: Date Code location  
(1968-1972 10-bolt style head shown)

### Cylinder Heads

*Inspect front, side & top, to verify style & model year*

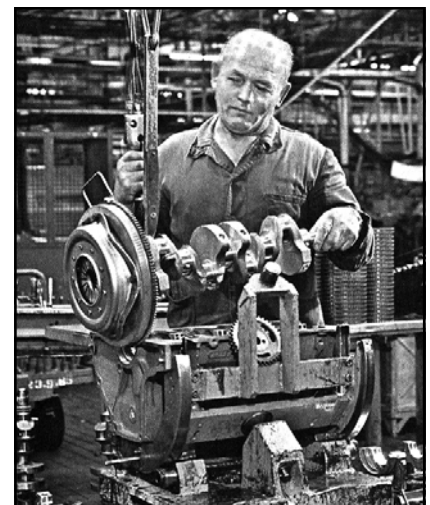





**6021 Oil Pump Cover**

*Includes all-new metal-piston type relief valve, calibrated max 3.5psi*

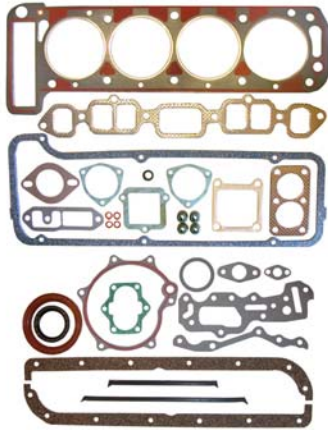

**6002 Full Gasket Set**

*Shown is original 10-bolt 1.9L set  
Also available for 12-bolt and 2.0L*



**6079A Oil Pressure Sender, GT**



**Used Engine Parts also available**

*Contact Opel GT Source with your needs  
opelgts@opelgtsource.com*



**6052, 6132 or 6132M Piston Sets**

*New Production  
Select STD or Oversize*



**6087 Camshaft Oil Dam**

*Improves camshaft lubrication  
Wide shoulder design for added stability*



**6054 Rod Bearing Set**

*New. Select STD or Oversize*



**6055 Main Bearing Set**

*New. Select STD or Oversize*



**6023 Timing Chain**

*Your choice from chain styles of open or closed-link (when available)*



**VKit Valves**

*Opel designs for best rocker geometry  
Select 1.9L or 2.0L  
Available with STD stems*



**6543 Valve Springs**

*New Reproductions  
Select Intake or Exhaust.*



**6045 Camshaft Bearing Set**

*4-Bearing 1971+ style shown*



**6024 Timing Chain Rail Set**

*Rails feature an improved harder-compound rubber design for better durability.*

**7000/Driveline**

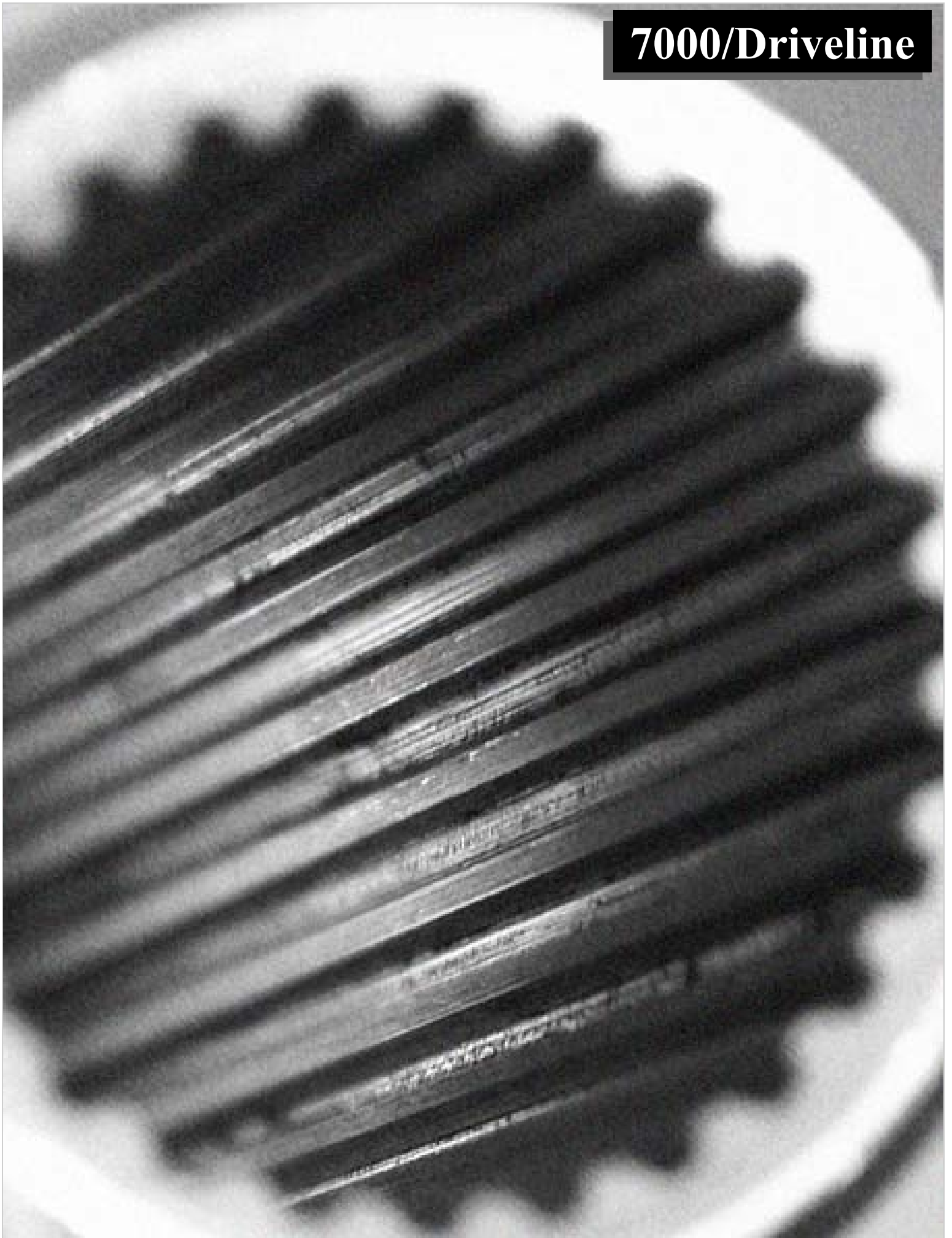

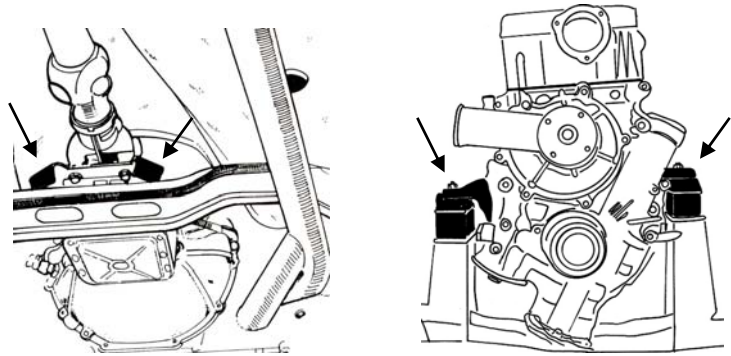

View underbody locations, to inspect conditions of mounts.  
New replacements better absorb engine vibrations,  
and help preserve critical driveline angles.

### Motor Mounts

#### 7001 MOTOR MOUNT 1.5L-2.4L

New production features NOS-replica "gold top" plus harder rubber and original height for optimal driveline angle. Fits GT with engines: 1.9L, 2.0L, 2.2L or 2.4L, Right or Left side.

#### 7038 HEAT SHIELD

Fits above motor mount on GT passenger side  
Extends mount life by shielding rubber from exhaust system heat radiating off of nearby manifolds

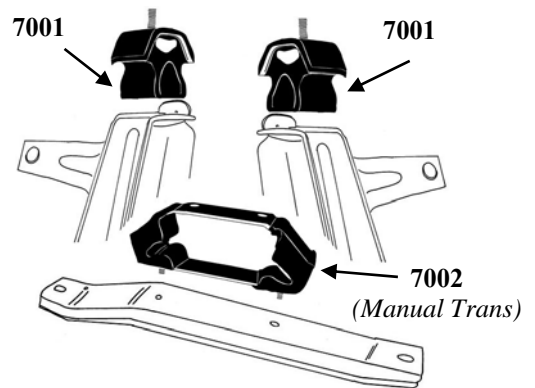

**7001K OPEL GT DRIVELINE MOUNT KIT**  
Includes #7002 4spd manual trans mount & 2 #7001 engine mounts for Opel GT at a reduced price

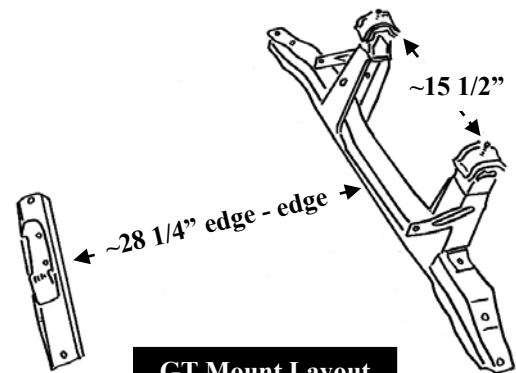
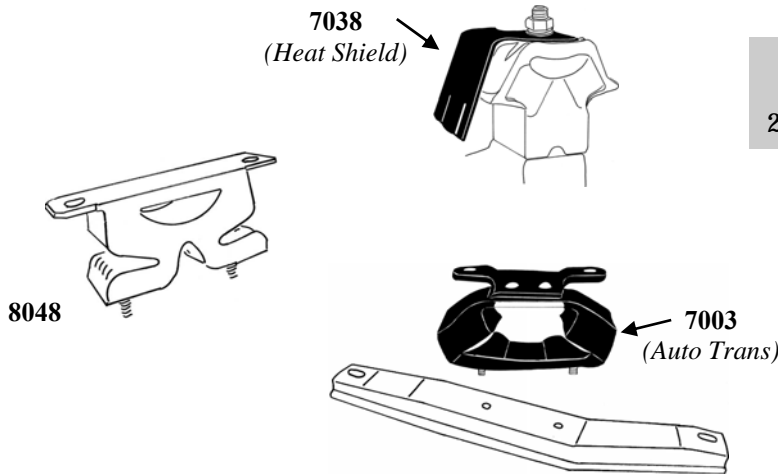

**GT Mount Layout**

### Transmission Mounts

**7002 4 SPEED TRANSMISSION MOUNT 1.9L**  
For GT with 4 speed manual transmission.

**7003 AUTOMATIC TRANSMISSION MOUNT 1.9L**  
A bolt-on mount for GT with automatic transmission. New re-designed top plate., so no modification is needed to install (as with prior versions of this mount). *The Opel GT automatic driveshaft has a short 16.5" length, so it is critical to install a mount of original dimensions (to preserve the correct u-joint angle).*

**8048 TRANSMISSION MOUNT**  
For GT retrofitted with Getrag 5 speed transmission  
Greater flexibility and cushion, original-style version

**8048A TRANSMISSION MOUNT**  
For GT retrofitted with Getrag 5 speed transmission  
Aftermarket style with stiffer round bushings



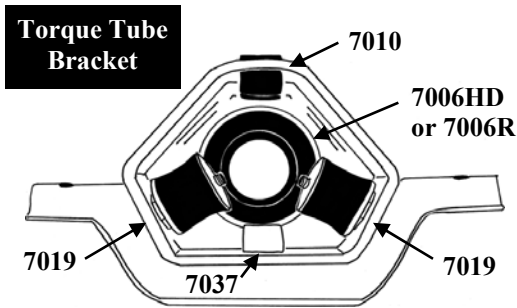
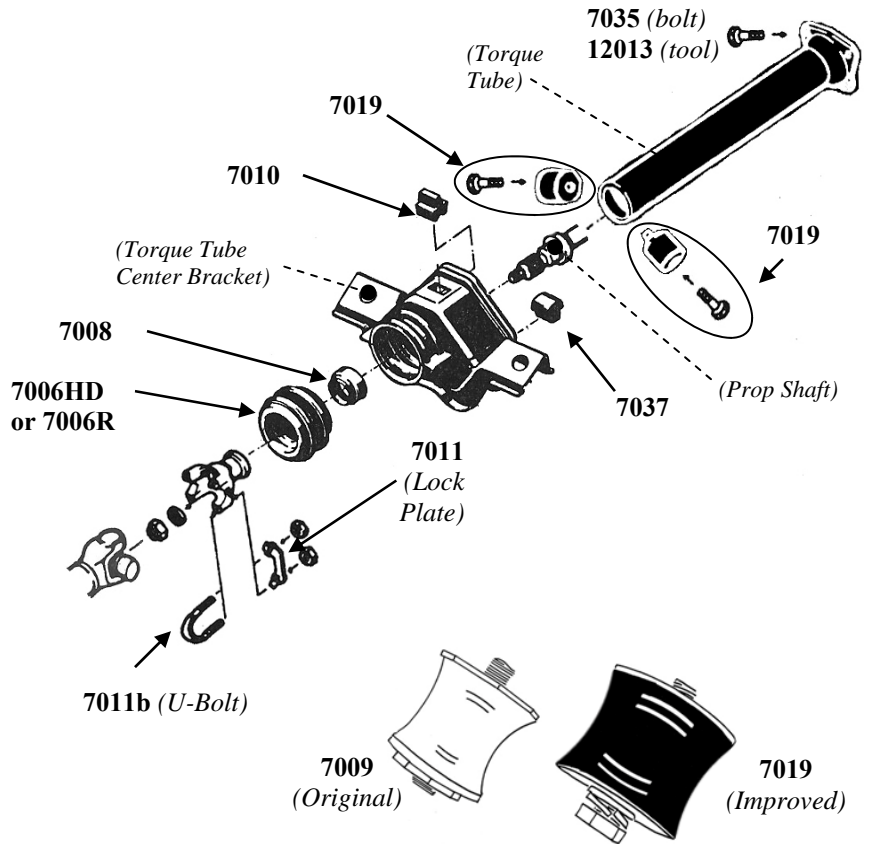

**Compare:** Our heavy-duty #7019 bushing is wider, to handle side-to-side travel at the central joint and support your ride quality. Special OEM-style "contour" design; Better where you want it to be!

## Torque Tube Parts

**7006HD CENTER SUPPORT DAMPING RING**  
1.9L Torque tube donut, features wide "lips" for fitment plus heavy duty stiffer center material. This is the round "donut-shaped" bushing in the bracket. Cushions rear drive shaft in the center support assembly. *Particularly Recommended for upgraded drivetrains or more spirited driving styles.*

**7008 CENTER SUPPORT BEARING**  
Bearing inside the 1.9L torque tube donut in the center support assembly. Special install notes available.

**7019 SUPPORT BUSHING, HEAVY DUTY**  
Supports the torque tube to the center support assembly. Updated "contour" OEM-style HD design. Two (2) required. Limits travel at joint. Recommended for improved durability and higher performance.

**7009 SUPPORT BUSHING**  
Same application as 7019 but narrower 1.3" width. Best for original 1.9L drivetrains. Two (2) required.

**7010 UPPER STOP, HEAVY DUTY**  
Small rectangular piece which fits above the torque tube in the center support assembly. Polyurethane replacement.

### 7011 U-JOINT LOCK PLATE

Two (2) required. Helps preserve vulnerable u-joint caps by allowing you to secure mount nuts at a light torque specification (so they won't get crushed).

### 7011B U-BOLTS

Sold as a pair.

### 7018 PINION SEAL

Located between torque tube and rear differential. Good item to replace when torque tube is serviced.

### 7034 U-JOINT 1.9L

1.9L U-joint. Specify front or rear. Original design is installed using injected plastic.

### 7035 BOLT

Torque tube to differential. Replacement allen-head design, easier to torque than original serrated bolts.

### 7037 LOWER STOP

Small hardware located below torque tube

### 12013 8mm SERRATED TOOL

Fits some driveline connector bolts. Offered as a convenience item.





Rear Axle gaskets, seals and internal hardware

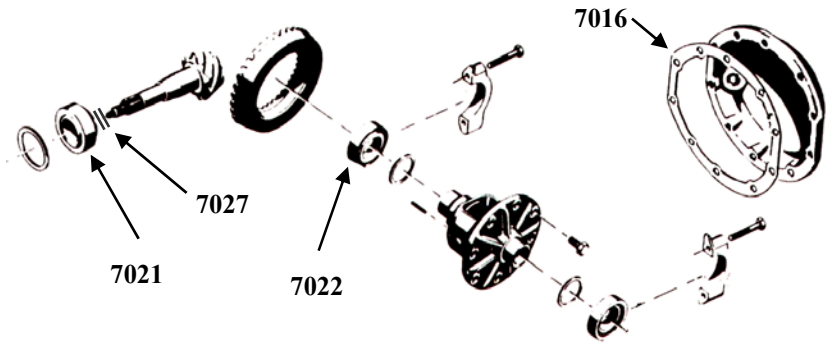

**7020 WHEEL LUG STUD, ORIGINAL LENGTH**  
Fits both front wheel hubs and rear axles

**7020XL WHEEL LUG STUD, LONGER**  
52mm long, 1/4 inch longer stud fits front or rear

**7021 PINION BEARING SET**  
Front & rear pinion bearing set with races. 1968-1975

**7022 CARRIER BEARING SET**  
Both carrier bearings in set with races. 1968-1975

**7027 CRUSH SLEEVE**  
*Required for differential rebuilds. New reproduction.*

**7028 PINION SPLINE/TORQUE TUBE SHAFT GEAR**

**7029 WHEEL LUG NUT, ORIGINAL**  
"Acorn" style, chrome, imported

**7040 REAR AXLE VENT TUBE**

**12091RTV "GEAR OIL" SEALER**  
3 oz. tube of silicone sealer for gear oil applications

**Differential Parts**

**7016 REAR AXLE PAN GASKET**  
This wide gasket seals the round cover plate. Replace whenever servicing axle, or when leaks occur.

**7018 PINION SEAL**  
Located between torque tube and rear differential. Good item to replace when torque tube is being serviced. Helps cure leaks at front of differential.

**7017 REAR TRAILING ARM BUSHING KIT**  
Rubber bushings for rear trailing arms.

**7023 PAN HARD ROD BUSHING SET**  
Set of 2. Rubber

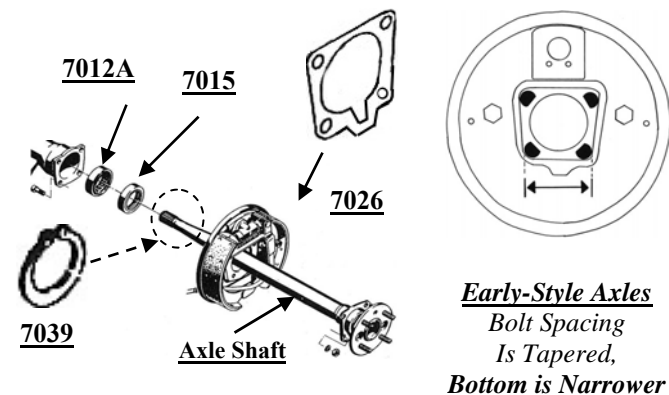

*Early-Style Axles*  
Bolt Spacing Is Tapered,  
Bottom is Narrower

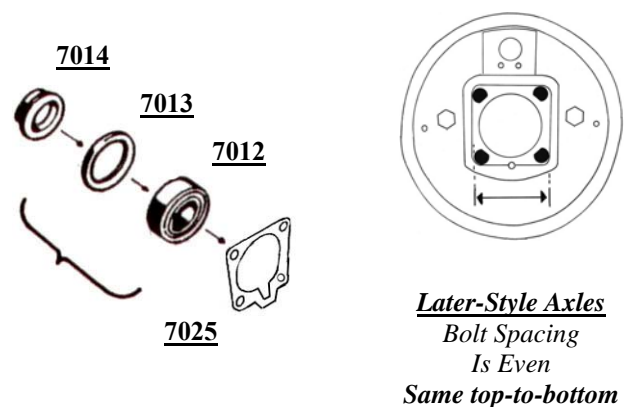

*Later-Style Axles*  
Bolt Spacing Is Even  
Same top-to-bottom

**Early Style Axle Shafts**

**7015 REAR AXLE WHEEL SEAL (1968-1971)**  
Critical to maintenance of proper axle oil levels.

**7026 REAR AXLE to PLATE GASKET**  
Can also be modified to work with backing plate

**7012A ROLLER BEARINGS**  
Special Order Item.

**7039 C-CLIP RETAINER, EARLY STYLE AXLE**  
Reproduction of Original Metal Clip

**Later Style Axle Shafts**

**7012 REAR AXLE WHEEL BEARING (1971-1975)**

**7013 O RING SEAL for REAR AXLE WHEEL BRG**  
Fits into groove on later-style axle wheel bearing. Helps prevent oil leaks and brake shoe contamination.

**7014 RETAINER for WHEEL BEARING, LATER**

**7025 REAR AXLE to PLATE GASKET**  
Paper. Can also be modified to work with backing plate

## Driveline Notes

The Opel drivetrain conveys the power output from the engine to the rear wheels.

Maintenance factors include needs for proper levels of gear oil, and securing supports at driveshaft and prop shaft connections, to protect the vulnerable splines of the pinion gear at the differential.

### Underbody Vibrations

This can include a "clunk" heard upon acceleration, which is commonly related to assembly and angles of driveline components, including the "torque tube" bracket and engine/transmission mounts.

### Orientation & Angles

The GT drivetrain is designed to lean 5 degrees towards the passenger side, so that the air filter will clear the underside of the hood. Maintaining correct driveline and u-joint angles, is also critical.

### Gear Oil Levels

It is critical to check and maintain gear oil levels within the rear axle housing, including verifying that there are no fluid leaks.

### Variations

Inspection of which style of axle your vehicle has should must be done so that correct replacement parts can be specified when required. Measurement of the bolt spacing on the rear brake backing plates will help identify "early" from "later" models.

### Gear Ratio

Inspection of the number of teeth on the internal main gear will determine its gear ratio (31-teeth are seen on the most common original Opel GT 3.44 ratio axles).

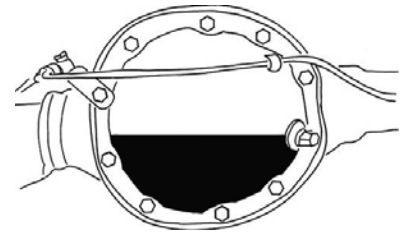

### ***Rear Axle Lubrication***

*Inspect and maintain a proper gear oil level in your rear axle*

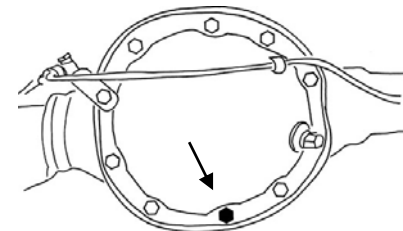

### ***Gear Oil replacement***

*Remove the center bolt to drain gear oil from axle*





**7001 GT Motor Mount**  
*New Reproduction of NOS design*



**7002 GT Transmission Mount**  
*Reproduction fits 4 Speed Manual*



**7003 GT Auto Trans Mount**  
*New Reproduction  
Redesigned top plate for bolt-in install*



**Used Driveline Parts also available**  
*Contact Opel GT Source with your needs  
opelgts@opelgtsource.com*



**7006HD Torque Tube Donut**  
*Reproduction bushing.  
Superior Heavy-Duty version*



**7019 HD Torque Tube Bushing**  
*New OEM-Style "Contour" Design  
Resists collapsing better than other styles*



**7018 Pinion Seal**  
*New Reproduction Seal  
Fits rear axle at torque tube*



**7035 Torque Tube Mount Bolt**  
*New Allen-Head design, Easier installation  
(to rear axle). 4 required per car*



**7008 Torque Tube Bearing**  
*Sturdy Metal bearing  
Fits on prop shaft within #7006*



**7010 Upper Stop**  
*Polyurethane  
Fits in upper torque tube Bracket*

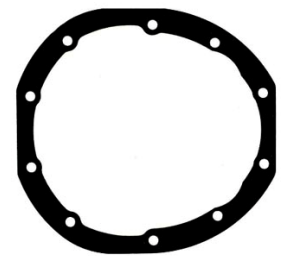

**7016 Rear Axle Pan Gasket**  
*Seals rear axle pan cover to  
differential housing*



**12091 Gear Oil Sealer**  
*Recommended RTV/Silicone, 3 oz. tube  
Offered as a convenience item*

# 8000/Trans & Clutch





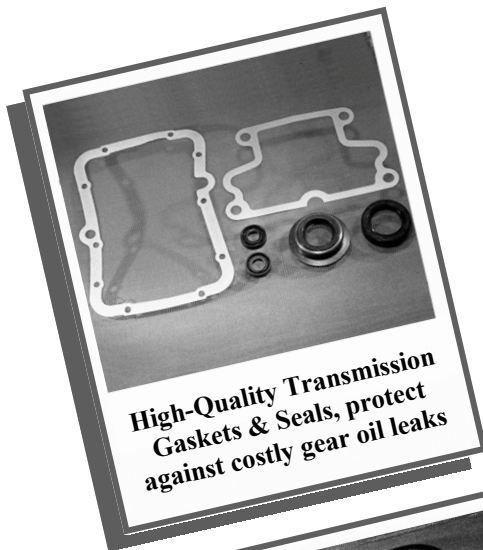

High-Quality Transmission Gaskets & Seals, protect against costly gear oil leaks



Critical transmission hardware and related parts

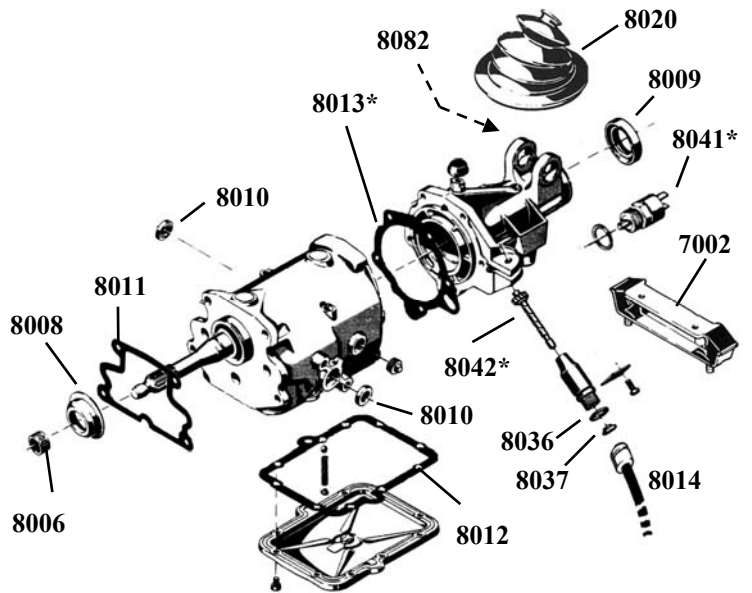

"Later" model manual transmission parts (1971-1975)\* are shown

### 4 Speed Manual Trans Parts

#### 7002 4 SPEED MOUNT 1.9L

For GT with 4 speed manual transmission.

#### 8014 SPEEDO CABLE

GT speedometer cable, 4 speed. Reproduction.

#### 8017 SPRING

This spring allows the shifter to return to neutral. 4spd

#### 8018 SPRING

Located on the 4 speed lower shifter shaft tower. 4spd

#### 8028 SPEEDO ANGLE DRIVE

Fits cable to speedometer gear output (1968-1970)

#### 8041 REVERSE LIGHT SWITCH

\*Round Switch fits rear of later style transmissions.

#### 8042 SPEEDO DRIVE GEAR, BLUE

\*Fits extension housing speedo drive. 3.44 ratio axles

#### 8046 SHIFTER SHAFT BRONZE BUSHING

#### 8047-4 SHIFTER KNOB, PLASTIC

Black plastic, 4 speed. Repro of original style knob.

#### 8047-M4 SHIFTER KNOB, METAL 4-SPEED

#### 8083 THRUST SPRING, 4SPEED

Fits into transmission rear, locates driveshaft correctly

### Seals and Gaskets

#### 8020 GT SHIFTER BOOT

Reproduction. Keeps heat, fumes and noise out of interior of car. It will stretch over original 4 speed or 5 speed knob during installation. Made from high quality military specification neoprene for long life and durability. NOTE: Using WD-40 eases installation.

#### 8082 GT SHIFT LINKAGE VINYL COVER

Fits on linkage beneath #8020 shifter boot

#### 8008 FRONT SEAL

Front cup, fits around front shaft of 4 speed.

#### 8009 REAR SEAL

Seals where drive shaft enters rear of transmission.

#### 8010 SHIFTER SEAL

4 speed shifter shaft. Right or left. Two (2) required.

#### 8011 GASKET

Critical bellhousing to 4 speed transmission gasket.

#### 8012 GASKET

4 speed pan at bottom of transmission.. Rectangular.

#### 8013 GASKET

4 speed rear, fits between case and rear housing. Round. \*Specify Early style or Later style transmission. (Style identification is in tech notes at end of section)

#### 8036 SPEEDO DRIVE O-RING OUTER SEAL

Fits around speedometer gear housing

#### 8037 SPEEDO DRIVE INNER CUP SEAL

Fits around speedometer drive gear.

#### 12091 RTV "GEAR OIL" SEALER

3 oz. tube of silicone sealer for gear oil applications

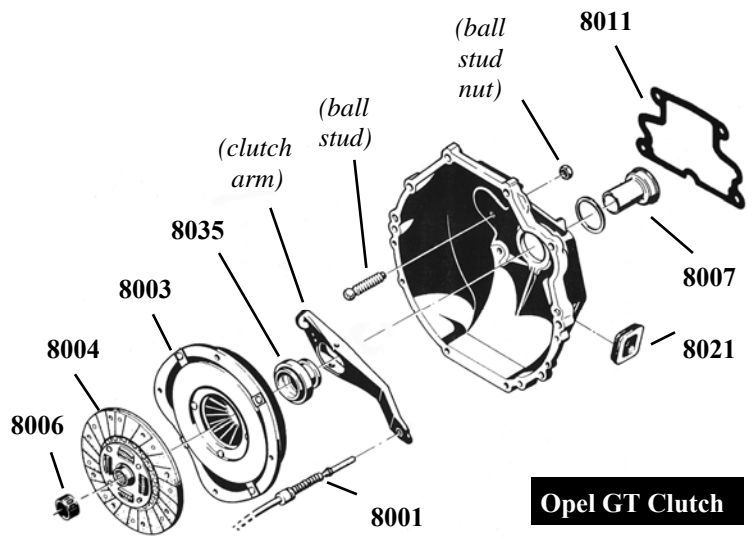

**Opel GT Clutch**



**8057**

**Convenience Shopping, with Opel GT Source**  
 Opel GT Source carries a complete line of all-new high-quality clutch and clutch-related parts, so you can get all you need all at one time. Saves time & labor, when you "Do it once, do it right"

**Related Hardware**

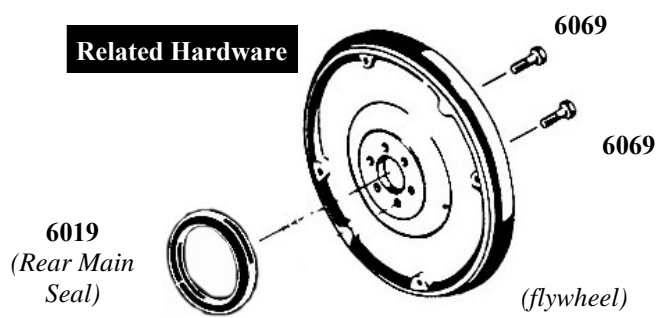

**Clutch Parts**

**8072S CLUTCH KIT**  
 New clutch kit included pressure plate, clutch disc, special all-metal release bearing and pilot bearing. Recommended for 1.9 & 2.0 drivetrains. *We also include a #8057 alignment tool with this kit for your convenience.*

**8003 PRESSURE PLATE**  
 All-new metal pressure plate. High-quality item. Best for 1.9L/2.0L. No Core fee or return required.

**8004 NEW CLUTCH DISK**  
 Clutch disk with high-quality friction material on an all-new metal plate. No core fee or return required.

**8035 CLUTCH RELEASE BEARING**  
 Special high-quality all-metal bearing. A smarter alternative to cheap plastic bearings offered for Opels.

**8006 PILOT BEARING**  
 Fits in rear of crankshaft of Opel CIH style engines.

**8057 CLUTCH ALIGNMENT TOOL**  
 Required to correctly align the friction disc when installing a clutch. Geared plastic.

**Clutch Related Hardware**

**8007 SLEEVE**  
 Sleeve for the clutch release bearing. 4 speed.

**8008 FRONT SEAL**  
 Front cup, fits around front shaft of 4 speed.

**8011 GASKET**  
 Bellhousing to 4 speed transmission gasket. Must replace whenever disassembling the clutch.

**8016 SPRING**  
 Clutch Return Spring, connects to trans mount bracket

**8021 BOOT**  
 Fits around the clutch arm in the bell housing.

**8049 BOLT WITH LOCK WASHER**  
 Pressure plate to flywheel. Allen head cap screw.

**6019 REAR MAIN SEAL, ENGINE**  
 Best replaced when doing clutch job, saves time/ labor

**6069 BOLT**  
 Flywheel to crank. 1.9L-2.2L. Attaching bolts. 6 per car



Custom-Machined Flywheels available

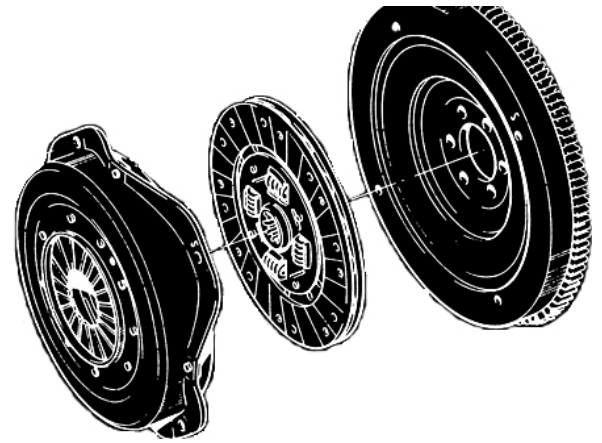

### Larger Clutches

*These provide much smoother shifting and allow upgraded Opel drivetrains to safely handle higher horsepower*

### High-Performance Clutches

#### 8080 FLYWHEEL

Custom CNC-machined and pinned flywheel to fit large 9" domestic S-10 clutch as a bolt-on unit. Recommended for engines from 120HP to 200HP. Provides a proper clutch arm angle, road-tested for durability. A modern upgrade, a more accessible alternative to higher-priced European clutch kits (replaces #8043, #8044, #8070 in our program)

#### 8081 CLUTCH KIT

9" Disc, Pressure Plate, Bearing and Tool to fit #8080 flywheel. Also includes 6 pressure plate to flywheel mounting bolts. Offered as an inexpensive convenience item for those who want the #8080 in a complete kit.

Racing style "lightened" flywheels are not recommended for street use. While a slight weight reduction can reduce spool-up time and improve takeoff response, maintenance of idle functions at streetlights and other stops requires a heavy rotating mass. If a flywheel is too light, continuous acceleration is required to maintain an idle, which will cost you fuel mileage as well as pedal effort.

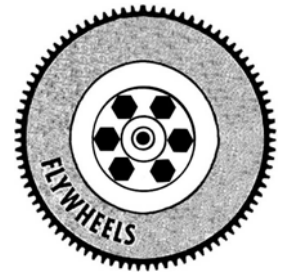

### Clutch Cable & Related

#### 8001 CLUTCH CABLE

New GT clutch cable, fits 4 speed or GETRAG 5 speed.

#### 8022 CLUTCH CABLE BOOT

Located under the car, on the lower end of the clutch cable. Helps to keep dirt from entering the clutch cable housing

#### 8023 BUSHING

Located where the clutch cable enters the firewall

#### 8023A WASHER

Fits between 8023 and sleeve.

#### 8024 E-CLIP

This clip is used to adjust the slack in the clutch cable and adjust the pedal height. Good idea is to also buy and carry an extra with the car in case you need it.

#### 8024A CLUTCH CABLE WASHER

Fits between 8023 and the E-Clip.

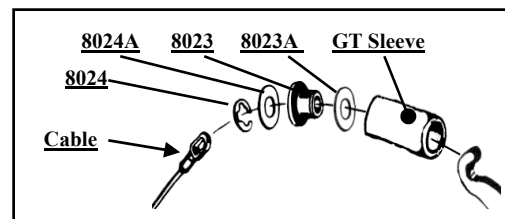

Clutch Cable Hardware at the Firewall

8001 (Cable)

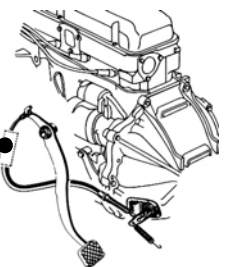

### Pedal Rubbers

#### 8025 BRAKE/CLUTCH PEDAL RUBBER

Rubber pad that fits over your clutch pedal (also fits brake pedal on GT with manual transmission).

#### 8026 ACCELERATOR PEDAL RUBBER

Rubber pad that fits over your accelerator pedal.



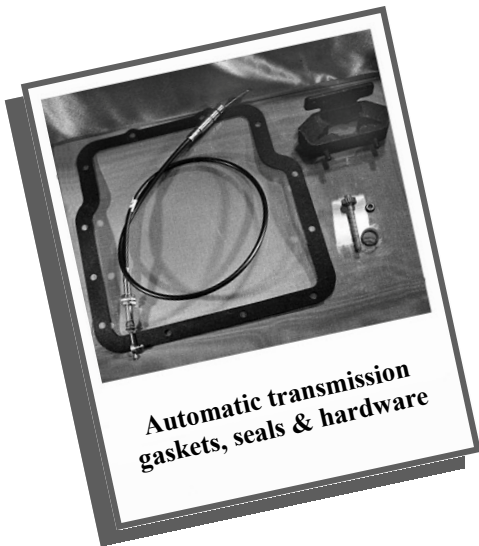

Automatic transmission gaskets, seals & hardware

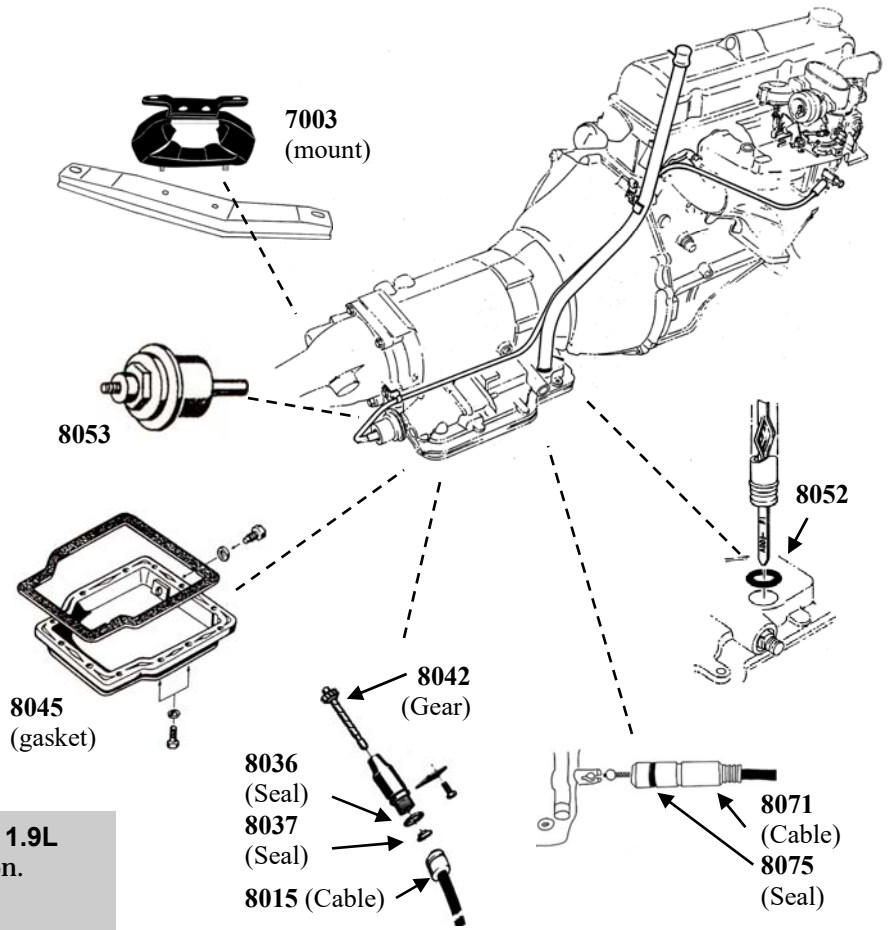
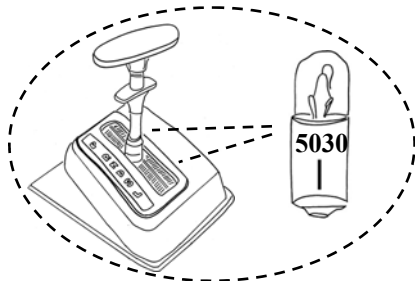

**Automatic Transmission Parts**

**7003 AUTOMATIC TRANSMISSION MOUNT 1.9L**

New mount for GT with automatic transmission. Minor modification required to swap over top bracket from old GT automatic mount. *The Opel GT automatic driveshaft has a short 16.5" length, so it is critical to install a mount of original dimensions (to preserve the correct u-joint angle).*

**8015 SPEEDO CABLE**

GT speedometer cable, Auto Transmission. Repro.

**8031 AUTOMATIC FLYWHEEL (FLEX PLATE)**

**8042 SPEEDO DRIVE GEAR, BLUE**

1968-1975 automatic. For use with 3.44:1 rear axle. Located in extension housing speedo drive.

**8053 AUTOMATIC TRANS VACUUM MODULATOR**

This unit senses engine load to properly downshift auto trans for over-taking and climbing steep hills. 1.9L.

**8059 THRUST SPRING, AUTO TRANS**

Fits into transmission rear, locates driveshaft correctly

**8064 GEAR**

Speedometer inner drive on trans output shaft, A/T

**8071 AUTOMATIC DETENT CABLE**

"Kickdown" cable for GT. New replacement for this often cracked, frayed and leaking cable. Helps stop leaks and restore operation of automatic transmission.

**5030 BULB**

Fits auto trans console on Opel GT. (2 req. per console)

**Seals and Gaskets**

**8045 AUTOMATIC FILTER KIT**

Includes pan gasket and oil filter for automatic trans.

**8036 SPEEDO DRIVE O-RING SEAL**

This seal is located between the driven gear housing and the transmission extension housing

**8037 SPEEDO DRIVE INNER CUP SEAL**

This seal is located between the driven gear housing and the plastic driven gear.

**8050 FRONT SEAL**

Seals the torque converter to the front case.

**8051 REAR SEAL**

Rear transmission to drive shaft. Automatic.

**8052 DIPSTICK TUBE O-RING SEAL**

Helps to seal a common fluid leak where the automatic transmission dipstick tube enters the case.

**8069 SHIFTER SHAFT SEAL**

Automatic shifter shaft.

**8075 DETENT CABLE O-RING SEAL**

Seal at transmission end of automatic kick down cable.





If you've ever reached to upshift from 4th gear, then you know you want a GETRAG

## GETRAG 5-Speed Transmission and Parts

Available REBUILT or USED, MODIFIED or UN-MODIFIED

Direct bolt-up replacement for the Opel GT  
(with some modifications, including accessories & services)

We also recommend inspection of your clutch for wear so you can order everything you may require at once, to save you time.

(We import and process transmissions in batches).  
Contact us in advance,  
to reserve your GETRAG

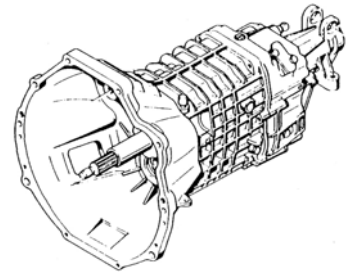

### Linkage Kit

(Contact us for details)

### GETRAG Installation Parts

#### CONVERSION

Conversion kit to install GETRAG in 4-speed Opel GT. Special Order Item, Subject to availability.

#### 8014/5 SPEEDO CABLE

GT speedometer cable for GETRAG 5-Speed. Repro.

#### 8047-5 SHIFTER KNOB, PLASTIC

Black Plastic, 5 speed. Original style look for GETRAG

#### 8047-M5 SHIFTER KNOB, METAL

Metal 5 speed knob. Modern look.

#### 8048A TRANSMISSION MOUNT

For Getrag 5 speed (type 240), aftermarket

#### 8054 DRIVESHAFT

Fits Getrag 5 speed into a GT. Core fee may apply.

#### 8059 THRUST SPRING

Getrag 5 speed. Driveshaft to transmission.

#### 8065 5 SPEED SHIFTER BOOT

#### 8068 5 SPEED DUST SHIELD

#### 8079 SYNTHETIC GEAR OIL

Synthetic gear oil, recommended for GETRAG

#### 5SPBRKT SIDE SUPPORT BRACKET

Support brackets from GETRAG to engine block, good used. Subject to availability.

#### 5SPLINK MODIFIED STOCK 5 SPEED LINKAGE

Custom built for your GT. Requires your 4 speed shifter to be shipped to OGTS.

#### 5SPMNT MODIFIED TRANS MOUNT BRACKET

For GT 5 speed installation. Note: Must ship your 4 speed bracket in for alteration first.

### GETRAG 5 Speed Transmission

#### 8038 GETRAG 5 SPEED (type 240)

Original transmission, good used condition  
Opel overdrive transmission with a 0.87:1 fifth gear.  
One of the finest quality built transmissions in the world. Works with your original clutch system, or our #8080 Flywheel. Some additional parts and modifications also required for installation. Subject to availability.

#### 8038R GETRAG 5 SPEED (type 240)

Rebuilt transmission. Subject to availability.

#### 8073 GETRAG with CONVERSION KIT

Includes parts and part modifications necessary to install GETRAG 5-speed transmission into an Opel GT originally equipped with a 4-speed manual transmission. (Additional parts are required if converting from an auto trans). Subject to availability.

#### 8058 REAR SEAL

Getrag 5 speed at driveshaft .

#### 8060 FRONT SEAL

Getrag 5 speed front input shaft seal.

#### 8066 5 SPEED SHIFTER PIVOT, NYLON

#### 8074 SEAL, SHIFTER SHAFT

Getrag 5 speed shifter shaft seal.

## Transmission & Clutch Notes

The Opel GT Manual Transmission will provide hundreds of thousands of miles of reliable service, when its internal fluid levels are kept up. The Opel GT Automatic Transmission also requires a consistent fluid level for operation, as well as well-functioning vacuum assist (drawn from the intake manifold). Performance upgrades include a 5-speed transmission conversion & a larger clutch.

### Model Identification

Inspection of the speedometer output and reverse switch locations must be done to verify which variation of the Opel manual transmission you have, so that correct replacement parts can be specified. Other hardware varied between Opel models, so an un-modified Manta or Kadett transmission will not shift properly in a GT.

### Gear Oil Levels

It is critical to check lubricant levels within the transmission, and to also verify there are no fluid leaks. This is best done by refilling the gearbox then placing a clean sheet of cardboard under the car, to identify any leak sources. We also advise installing higher-quality material gaskets here, for a security of operation over the longer-term.

### Automatic Transmission

Proper sealing at the dipstick tube and replacement of the inner filter every 24,000 miles of typical driving (or 12,000 city miles) is required. Completely eliminating all possible leaks of engine vacuum is also required, to assure you experience a “crisp” and prompt shifting response while driving.

### Higher-Performance Clutch

For performance-upgraded drivelines, Opel GT Source offers special clutch assembly hardware, to provide much smoother shifting and allow your drivetrain to safely handle higher horsepower. When installing a modified clutch, always make sure it is configured for a correct internal angle between the clutch arm and pressure plate, for longevity of use.

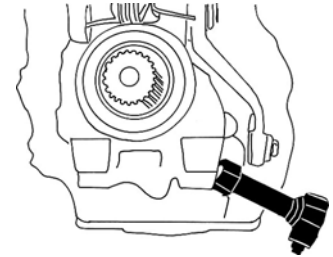

***Early Style Transmission***  
*Speedometer output located on passenger side, plus other unique hardware*

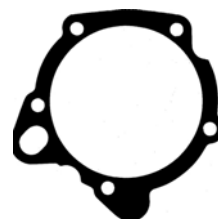
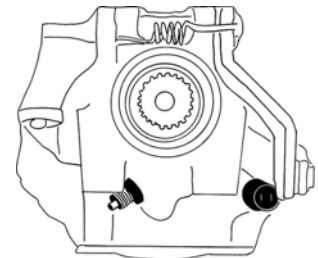

***Later Style Transmission***  
*Speedometer output located on driver's side, plus a rear-mounted reverse switch*



**8014 GT Speedometer Cable**  
*Specify application:  
4 Speed Manual or Auto Trans.*



**8001 GT Clutch Cable**  
New Reproduction  
*Replaces a stretched or broken cable*



**8020 GT Shift Boot**  
New Reproduction  
*Helps keep heat & noise out of interior*



**8009 Trans Rear Seal**  
*Fits at rear of 4 Speed Manual  
Transmission, where driveshaft enters*



**8011 Bellhousing Gasket**  
New Reproduction Gasket  
*Fits manual trans at bellhousing*



**8035 Clutch Release Bearing**  
New All-Metal Design  
*Alternative to cheaper plastic designs*



**7002 GT Transmission Mount**  
*Reproduction fits 4 Speed Manual*



**8012 Transmission Pan Gasket**  
New Reproduction  
*Fits 4 Speed Manual Transmission*



**8071 GT Detent "Kickdown" Cable**  
*New Replacement cable for GT  
with automatic transmission*



**Used Transmission Parts available**  
*Contact Opel GT Source with your needs  
opelgts@opelgtsource.com*



**8080 Flywheel**  
*Custom Machined for Larger S10 Clutch  
Recommended for 120-200HP engines*



**8072S Clutch Kit**  
*All New, Includes Disc, Pressure Plate  
Release & Pilot Bearings, Tool*

# 9000/Fuel System

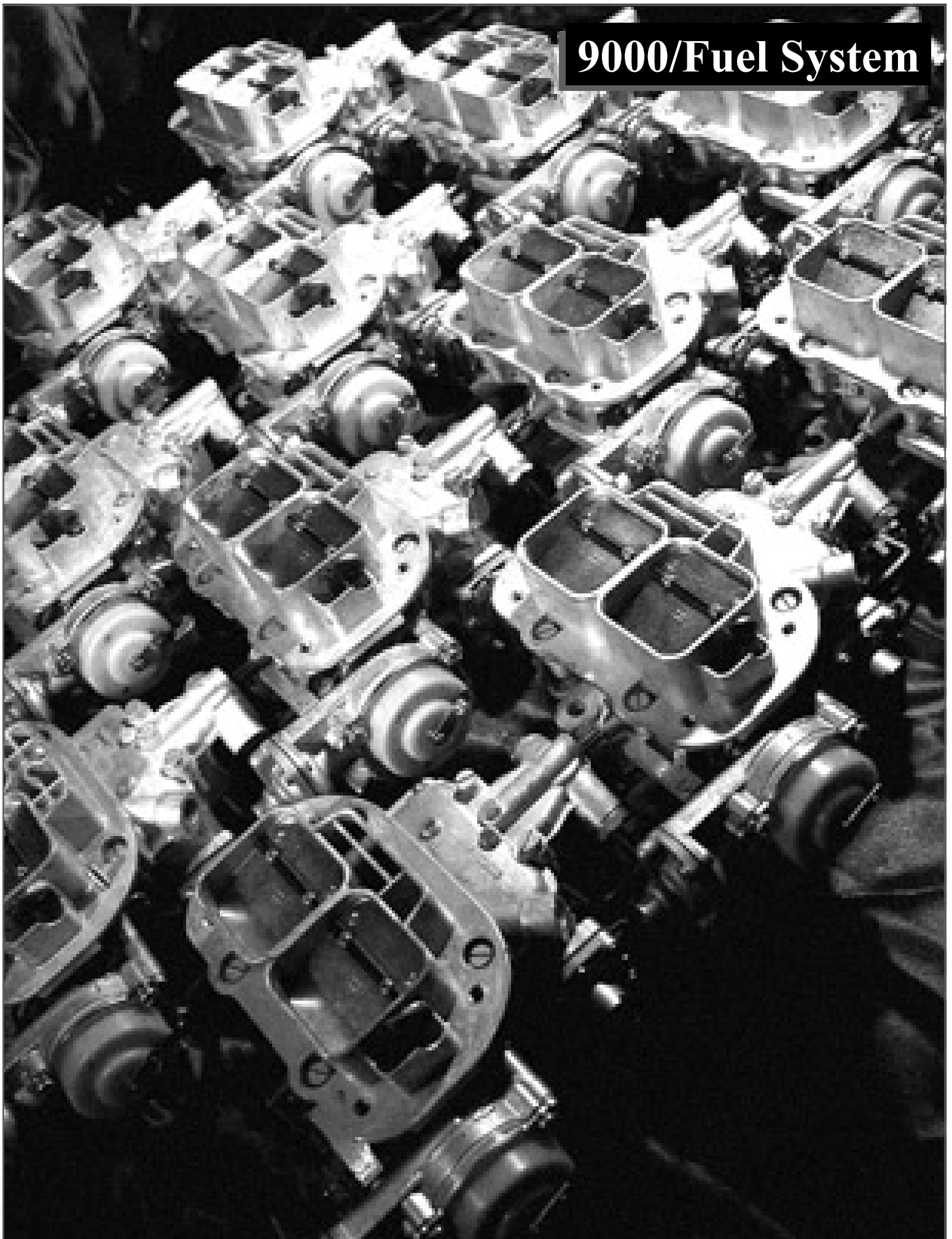



## SOLEX CARBURETOR

Original Solex-brand carburetors can offer good fuel mileage and roadworthy performance.

We offer rebuild kits and other required installation hardware, for original Opel models.



Installation parts and hardware for the original Solex brand carburetor

*However design weaknesses have led most used Solexes to develop driving problems, often caused by heat warpage and internal part wear. When symptoms include an inability to idle at a consistent speed and dumping of gas down the carburetor throat, we strongly recommend to owners to consider a replacement Weber*

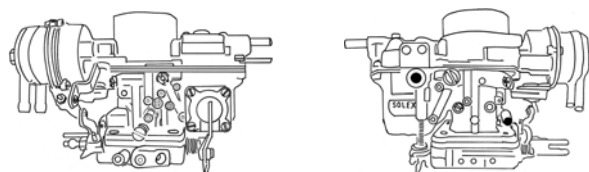
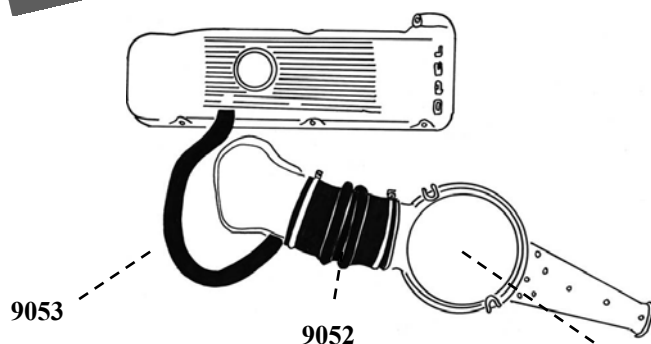

1968-1972 Solex carburetor, side views

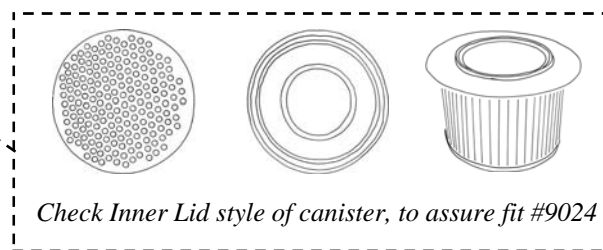

### Solex Carburetor Related

#### **9021 1.9L SOLEX REBUILD KIT**

Rebuilt kit contains; Needle & seat, accelerator pump diaphragm, choke diaphragm, and misc. gaskets and seals. When ordering, please specify year and style (To identify 5-bolt vs. 7-bolt is see our "part list").

#### **9004 GASKET CARB TO INTAKE MANIFOLD**

Carburetor to intake manifold, thick gasket with plastic eyes to prevent carburetor base plate warping. Installation instructions included.

*NOTE: You will also need 9018 if your engine is equipped with a heat shield under the carburetor.*

#### **9018 GASKET HEAT SHIELD TO INTAKE**

Carburetor heat shield to intake manifold, thin.

#### **9005 THROTTLE GROMMET, GT**

Accelerator linkage to firewall, passenger side. Sturdy polyurethane for best linkage throttle response.

#### **9006 THROTTLE GROMMET, GT**

Accelerator linkage to firewall, driver side. Improves linkage throttle response.

#### **9060 SOLEX BALL NUT**

Ball nut that connects to stock throttle linkage.

#### **9011 LOCK SPRING**

Accelerator linkage to carburetor also for drivers side throttle linkage to body pivot.

#### **9024 AIR FILTER**

Stock GT, 1.9L. Note: Check the inner lid of air filter canister and see above diagrams to assure correct fit.

#### **9024KN K&N AIR FILTER**

K&N High-Flow GT 1971-73 stock air filter element. Washable & Re-usable! Note: Check the inner lid of the air filter canister to assure correct fit.

#### **9034S INTAKE MANIFOLD STUD KIT (SOLEX)**

Solex-length kit, Set of 4 new studs with nuts and washers, helps to prevent common vacuum leaks by securing carburetor to intake manifold. .

#### **9042 FUEL FILTER**

Clear plastic "see-through" type for fuel line to carb.

#### **9052 CONNECTOR BOOT, for STOCK GT AIR CLEANER**

This is a ribbed rubber connector that fits between the stock GT air cleaner canister to the Solex hat.

#### **9053 FORMED HOSE**

Original Opel breather hose which connects between the stock GT air cleaner and the large port on the GT aluminum valve cover.

## FUEL SYSTEM

For reliable and trouble-free daily operation, NEW European-made Weber-brand carburetors have been the preferred choice for Opel owners for about 40 years.

Your carburetor selection is an important choice, and Opel GT Source has both a complete line of correct parts and also the technical know-how to make your installation easier.

*We have helped thousands of Opel owners in making the correct decision for their Opel application, based on different versions that are available, so you can contact us to determine which is best for your Opel driving application.*



Get your New Weber Carb  
from Opel GT Source



Electric

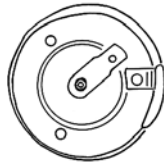

Water

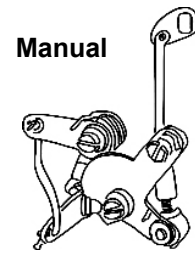

Manual

*We offer a choice of choke designs; Give us a call to determine which is best for your driving style*

*European-manufactured Webers feature an official trademark cast visibly into the top metal (other copies substitute a decal here)*

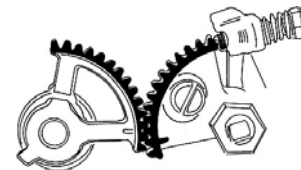
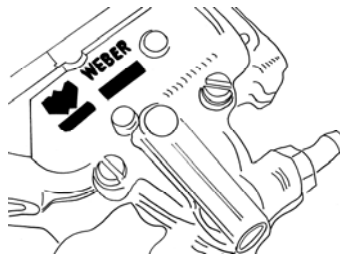

*38DGAS models feature a dual-drive design, for faster takeoffs*

### Weber Carburetors

#### **9017 CARBURETOR, WEBER DGV-SERIES**

Genuine, Trademarked and European-Made Weber with an Electric Choke. Recommended bolt-on replacement of original Solex.. Combines a high-quality of design and manufacturing with ease of tuning. *See next page, for additional parts required to install.*

#### **9017K WEBER CARB KIT**

Includes #9017 Weber carb, #9004 & #9018 gaskets, plus #9005, #9029, #9060, #6026, #9034W hardware

#### **9016 CARBURETOR, WEBER DGV-SERIES**

Genuine, Trademarked and European-Made Weber with a Water Choke. Recommended bolt-on replacement of original Solex if you want to retain its Water Choke. Combines a high-quality of design and manufacturing with ease of tuning. *Other parts required for installation, including a recommended #9031 converter, are listed on a following page*

#### **9067 CARBURETOR, WEBER DGV-SERIES**

Genuine, Trademarked and European-Made Weber with a Manual Choke. Direct bolt-on replacement of the original Solex. Other parts required for installation are listed on a following page. You will have to supply a common choke cable and hardware. *Installation notes available on request with purchase*

#### **9028 WEBER DGAS CARBURETOR**

Genuine, Trademarked and European-Made Higher-Performance Weber. Features the convenience of a down- draft design with two 38mm barrels that work simultaneously using gear linkage for greater off-the-line fuel flow. Bolts to original intake manifold and linkage with minor modifications. *Adds increased horsepower to a well-built engine (not recommended for original or low-compression motors).* Specify water or electric choke. Best when installed with our #9035 gasket set.

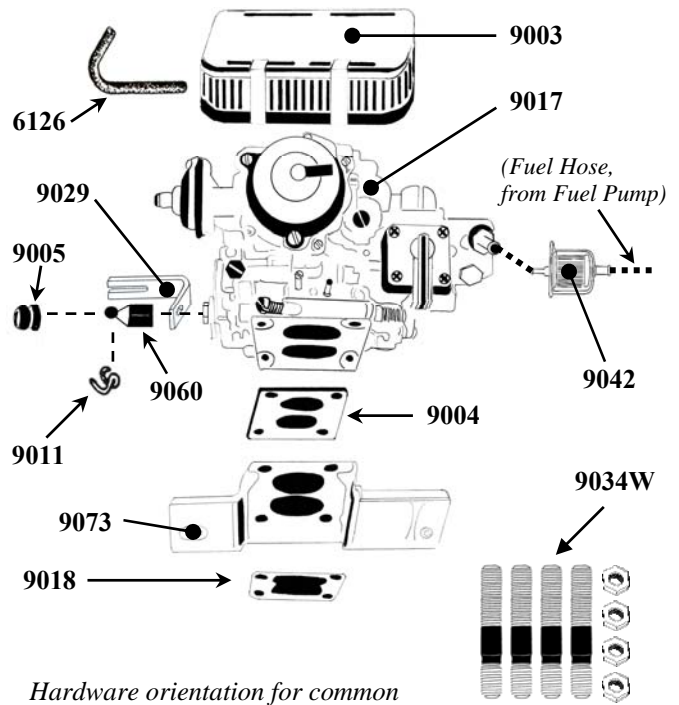

Hardware orientation for common Weber installation, is illustrated

## Weber Carb Installation Hardware

### 9004 "THICK" GASKET, CARB to INTAKE

**Fits** Weber DGV-Series carburetor to intake manifold, this thick gasket with plastic eyes also helps insulate from heat to prevent carburetor base plate warping. Can also help cure "stumble and surge" response, caused by a common vacuum leak between the carb and the intake manifold. *NOTE: You will also need a thin #9018 gasket if your engine is equipped with a heat shield under the carburetor.*

### 9018 GASKET, HEAT SHIELD TO INTAKE MANIFOLD

Carburetor heat shield to intake manifold, thin. Install under original heat shield or our #9073 reproduction shield.

### 9005 THROTTLE GROMMET, GT

Accelerator linkage to firewall, passenger side. Improves linkage throttle response. Also helps minimize wear at critical throttle shaft bushing of carburetor. Polyurethane.

### 9006 THROTTLE GROMMET, GT

Accelerator linkage to firewall, driver side. Improves linkage throttle response.

### 9011 LOCK SPRING

Accelerator linkage to carburetor, keeps linkage end from slipping off of ball nut.

### 9029 LINKAGE ADAPTOR BRACKET

Special throttle linkage bracket that eases installation of your Weber. *Note: Recommended installation is with our #9060 replacement ball-nut.*

### 9060 BALL NUT

Ball nut that connects to stock throttle linkage. Special deeper length to better fit Weber Carburetors, helps prevent binding of linkage at carb

### 9031 OPEL WATER CHOKE HOUSING ADAPTOR

Proper water choke fitting for Weber DGV-Series. Should be purchased when ordering water-choke Weber DGV series for installation on Opel GT.

### 9034W INTAKE MANIFOLD STUD KIT

Special length for a better fit for Weber carburetor installations. Set of 4 new studs with nuts and washers, helps to prevent common vacuum leaks by securing carburetor to intake manifold.

### 9042 FUEL FILTER

Clear plastic "see-through" type filter for fuel line to carb. Also recommended in fuel line near output of gas tank to collect any debris from internal corrosion. Recommended for easier fuel system diagnosis

### 9009 FUEL FILTER, 1973-74

Special 3-port fuel filter for original 1973 GT fuel system, includes port for return line to tank.

### 9073 CARBURETOR HEAT SHIELD

Reproduction version, helps isolate carburetor from heat. Helps reduce "vapor lock" and other driveability problems arising from higher-percentage ethanol blends now offered in pump gas.

### 9055 THROTTLE RETURN SPRING

New production. Connects linkage to tab on firewall.

### 12017c GASKET SEALER

Permatex "High Tack" gasket sealer in a 4 oz. can. Recommended for sealing carburetor gaskets, to prevent vacuum leaks from occurring at a common problem area. *Offered as a convenience item, to save you the time and cost of a separate trip to the store.*

## Weber Air Filter - Basic

### 9003 WEBER AIR FILTER

For Weber DGV-Series, or Weber 38 DGAS. Features High-quality components from original manufacturer. Comes complete with rectangular chrome top and bottom, 2 1/2" washable filter element, mount gasket, and an elbow to attach your #6126 hose.

### 6126 HOSE

Connects #9003 air filter to GT valve cover

### 9033 AIR FILTER ELEMENT

Replacement rectangular 2-1/2" tall Weber air filters. Washable. This fits standard #9003 filter kits.

### PF200 PLASTIC ELBOW FOR HOSE TO FILTER

Connects #6126 hose to #9003 Weber Air Filter

### 9032 AIR FILTER ELEMENT

Replacement rectangular 1-1/2" tall Weber air filters. Washable. This fits "shorter" filter kits.

### 9062 WEBER AIR FILTER CLIPS

Choose 2 1/2" or 1 1/2" tall element. Set of 4.

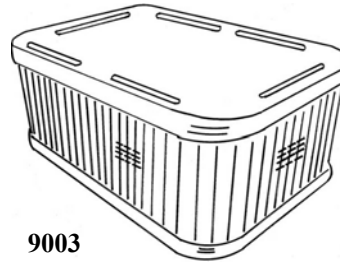

9003

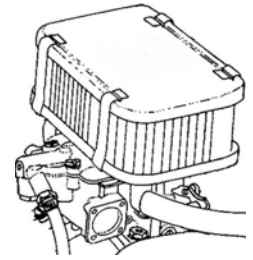

(Installed View)

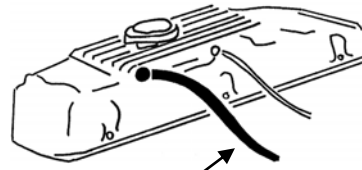

6126

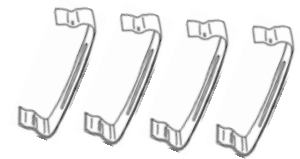

9062 (set of 4)

## Weber Air Filter - Adaptor

### 9019 ADAPTOR

Weber DGV-Series to original GT air cleaner cap. Best option for those wanting original under-hood appearance. May require modification to clear the hood of the GT.

### 9024 AIR FILTER

Stock GT, Identify lid style of air filter canister to assure fitment.

### 9052 CONNECTOR BOOT, for STOCK GT AIR CLEANER

This is a ribbed rubber connector that fits between the stock GT air cleaner canister to the cap outlet.



(Cap)

9019



9052

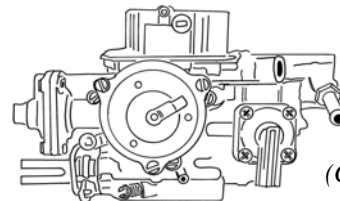

(Carb)

9024

## Adaptor

## Weber Performance Filter Parts

### 9063 WEBER SNORKEL "DOME" KIT

Best option for performance installations such as a starting point for a custom DIY cold-air set-up. Also best for those who seek to draw in cooler air, resist carburetor heating issues, or to retain the stock appearance of a fender mounted air cleaner. Also required for some hi-perf. engine applications. (Can also be used with #16001 filter & tube extension).

### 9024KN K&N AIR FILTER

K&N High-Flow GT 1971-73 stock air filter element. Washable & Re-usable! Fits: Stock GT, Identify lid style of air filter canister to assure fitment.

### 9052 CONNECTOR BOOT, for STOCK GT AIR CLEANER

This is a ribbed rubber connector that fits between the stock GT air cleaner canister to the dome outlet.

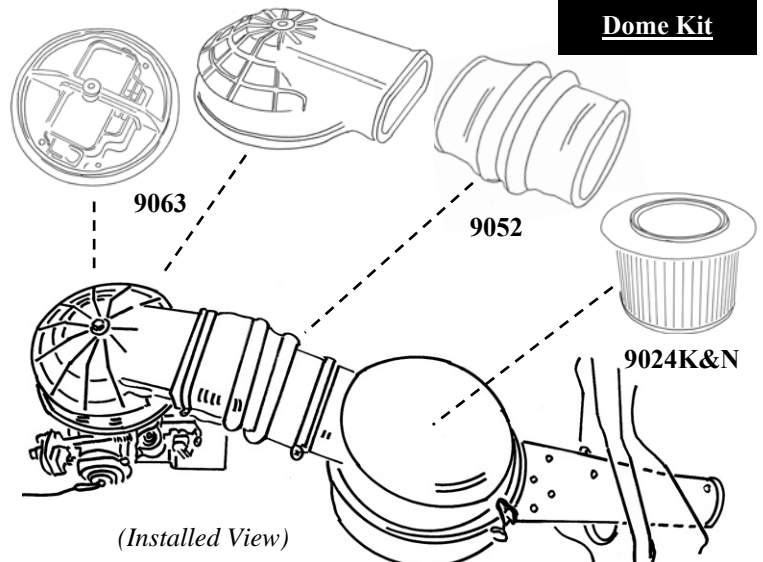

(Installed View)

## Dome Kit



## Weber Carb Parts and Kits

With today's fuel blends increasingly more corrosive due to ethanol, replacing rubber diaphragms and other parts with only the highest quality available has never been more critical! We carry only authentic Weber-brand components.



*We carry only Trademarked, European-made Weber Jets, which are tested for fuel flow accuracy*

## **Weber Carburetor: Replacement Parts**

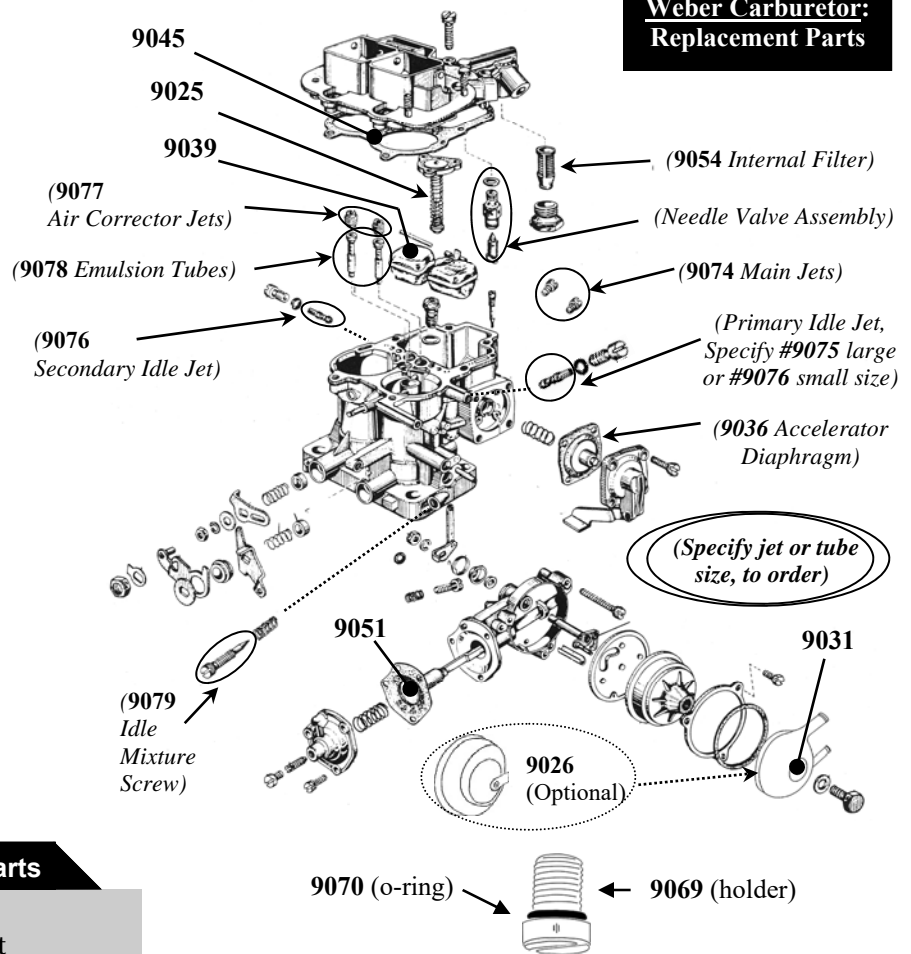

## **Weber Carburetor Hardware & Service Parts**

### **9020 WEBER REBUILD KIT**

Weber DGV-Series & 38 rebuild kit. Basic kit (does not include power pump #9025, choke cut out diaphragm #9051 or #float 9039).

### **9020A WEBER REBUILD KIT, w/ POWER PUMP**

Weber DGV-Series & 38 rebuild kit includes #9025 power pump.

### **9025 POWER PUMP**

Inside float bowl for Weber DGV-Series.

### **9026 WEBER ELECTRIC CHOKE ELEMENT**

New Weber electric choke element. Can also be used to convert a 3DGV-Series Water choke to an Electric choke Weber. *Note: Will not fit manual choke Webers.*

### **9036 ACCELERATOR PUMP DIAPHRAGM**

Weber DGV-series and DGAS. Square.

### **9039 WEBER FLOAT**

Plastic float fits DGV-Series & 38 Weber carburetors.

### **9045 GASKET, WEBER FLOAT BOWL**

Weber float bowl gasket. Fits: DGV-Series & 38 Weber.

### **9051 CHOKE CUT OUT DIAPHRAGM**

Choke pull-off diaphragm. Fits both water and electric choke DGV-Series & 38 Weber

### **9054 WEBER INLET FILTER**

Fits below fuel inlet of Weber DGV-series and DGAS carburetors

### **9069 WEBER IDLE JET HOLDER**

Replaces anti-diesel solenoid in older "smog legal" carb

### **9070 O-RING**

Fits primary idle jet, a common "hidden" vacuum leak source. Specify large or small width.

### **9074 MAIN JET, DGV-Series**

Specify dimension wanted.

### **9075 IDLE JET, LARGE WIDTH, DGV-Series**

Specify dimension wanted.

### **9076 IDLE JET, SMALL WIDTH, DGV-Series**

Specify dimension wanted.

### **9077 AIR CORRECTOR JET**

Weber DGV-series, specify dimension wanted.

### **9078 EMULSION TUBE**

Weber DGV-series, specify dimension wanted.

### **9079 IDLE MIXTURE SCREW, DGV-Series**

### **9080 IDLE MIXTURE SCREW, 38 Webers**

### **9090 VENTURI, DGV-series**

### **9091 VENTURI, 38-Size Weber**

### **14019 WEBER CARBURETOR BOOK**

Explains DGV-Series, DGAS Weber carbs. 180+ pages.

## Fuel Pump & Hardware

### 9010 FUEL PUMP, 1968-1974

High quality European manufactured mechanical pump. We imported these directly when owner feedback indicated a high failure rate of domestic "flat top" style fuel pumps.

Requires #6051 spacer for correct installation.

### 6051 FUEL PUMP SPACER 1.5L-2.0L

Required for installation of manual fuel pump. Spacer fits between fuel pump and timing cover. Can be installed with separate #6017 gaskets.

### 6017 GASKET, FUEL PUMP

Fuel pump to timing cover. Two (2) required.

### 9040 FUEL SPACER 1.5L-2.0L

Steel. Two (2) 6017 required.

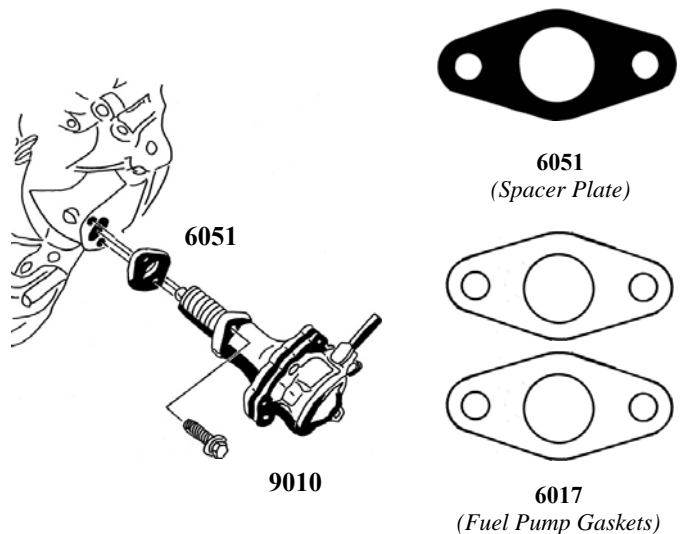

## FUEL SYSTEM TIPS

*Vintage cars require additional inspection and protection here.*

(1) Verify fuel flows freely, without obstruction or clogging, by locating clear "see through" type filters in the lines near the output of the tank and the input to the carburetor.

(2) Verify that a minimum of 2.5psi fuel pressure is supplied to the carburetor, by testing with a fuel pressure gauge.

Be aware that fuel pumps can be damaged in cars left sitting, as ethanol-blend fuel "eat" rubber diaphragms, and that "flat top" style domestic fuel pumps have been to have a high failure rate.

(3) If a Weber carb is suspected of flooding, consider adding an adjustable "fuel pressure regulator" to the system to restrict pressure. *We recommend metal-housing versions, as some plastic-based regulators can leak.*



Fuel Pressure Gauge

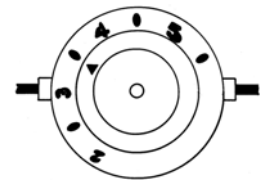

Fuel Pressure Regulator

## Electric Fuel Pump & Hardware

### 9066 ELECTRIC FUEL PUMP

Replacement low-pressure electric fuel pump for carbureted Opel engines. Often installed by owners who wish to bypass or eliminate the stock mechanical fuel pump, in some cases as a remedy for "hot restart" issues. *Compatible with our #9041 fuel pump block-off plate and #6017 fuel pump gasket (if timing cover port is to be covered).*

### 9041 FUEL PUMP BLOCK-OFF PLATE, 1.5L-2.0L

Steel. One (1) 6017 required. Optional version of #6051 plate. Required when converting to electric fuel pump.

### 6017 GASKET, FUEL PUMP

When installing #9041 plate, one (1) required.

### 9042 FUEL FILTER

Clear plastic "see-through" type filter for fuel line to pump, to assure tank debris doesn't damage pump.

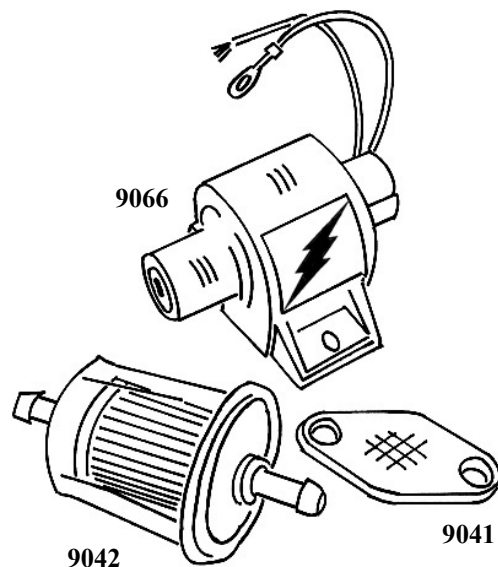

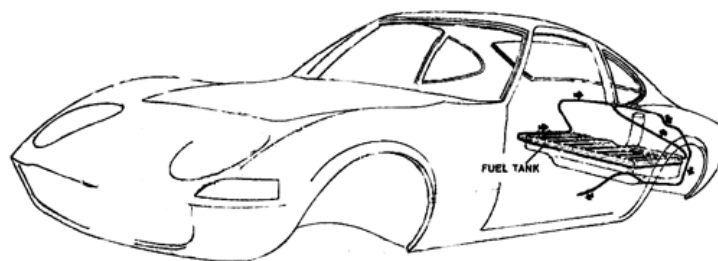
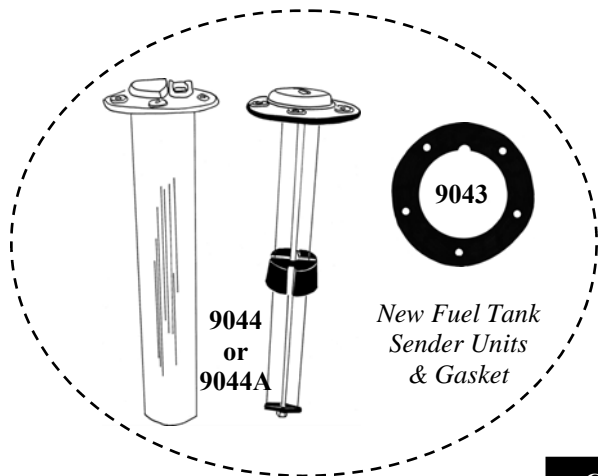

**GT Fuel Tank  
Parts & Hardware**

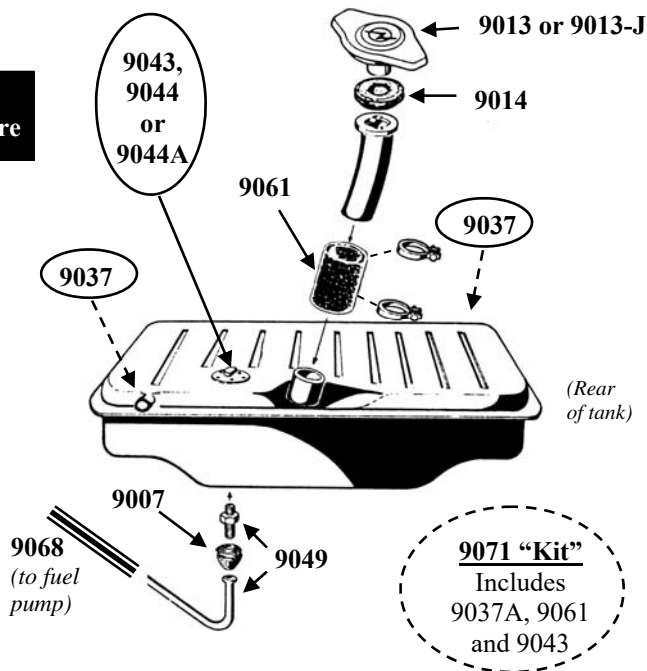
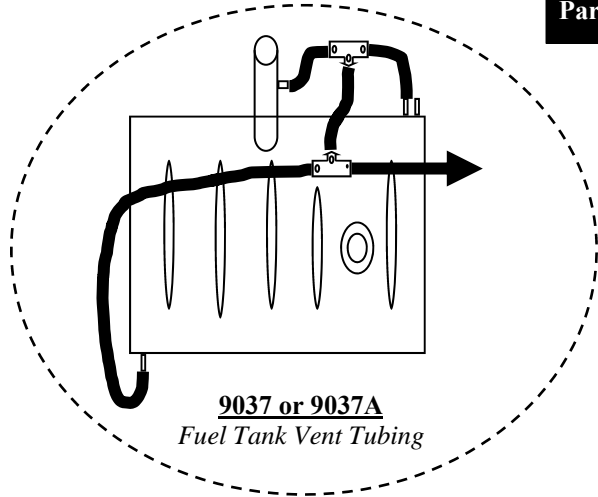

**Fuel Tank Hardware**

**9007 BOOT**  
GT fuel line to body at gas tank rear. Helps keep exhaust fumes from affecting interior of car. Repro.

**9014 FILLER NECK GASKET, GT**  
Reproduction rubber gasket that seals filler neck to rear body panel. Made of durable neoprene.

**9013 GT GAS CAP WITH KEYS**  
European reproduction of the Original GT gas cap. Comes with two (2) keys. (Extra key blanks can be ordered as part #12037B, specify "gas cap" type).

**9013-J GT GAS CAP, GT/J KEYLESS STYLE**  
Lower-cost, black-painted alternative GT gas cap.

**9037 GAS TANK VAPOR/VENT TUBING**  
Helps seal a common source of fuel smell in the passenger compartment of the Opel GT. Includes 12 feet of GT gas tank vapor lines that you cut to fit. Comes with installation instructions.

**9037A GAS TANK VAPOR/VENT TUBING KIT**  
#9037 hoses, plus "T" fittings and instructions.

**9042 FUEL FILTER**  
Clear plastic type filter fits fuel line near output of tank. Helps keep tank debris like rust out of fuel pump input

**9043 GASKET**  
Round 5-hole cork ring for GT fuel tank sending unit.

**9044 FUEL TANK SENDING UNIT, GT**  
OEM. Replaces the often-corroded original unit.

**9044A FUEL TANK SENDING UNIT, GT**  
Aftermarket, lower-cost unit, features original height

**9047 SEAL**  
Fits underside of GT gas cap where it sits on filler neck. Helps keep air and condensation out of tank.

**9049 FUEL FITTING & LINE at GAS TANK**  
This is the fuel exit line in the bottom of the gas tank. Comes with metal line, double female fitting, compression nut & ferrel.

**9061 GT FILLER NECK HOSE**  
Hose from the gas tank to the filler neck, GT.

**9068 PLASTIC FUEL LINE**  
Replacement underbody line fits GT from tank outlet to front of car. Original-style plastic, which is safer than rubber (due to degradation by ethanol fuel mixes)

**9071 GAS TANK "SEAL KIT"**  
Includes #9037A, #9061 and #9043



**Improved fuel delivery plus convenience of a downdraft. Available as a bolt-on using our installation hardware.**

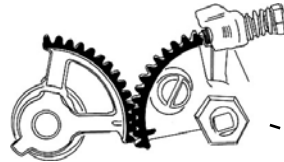

*DGAS models feature a dual-drive design, for faster takeoffs*

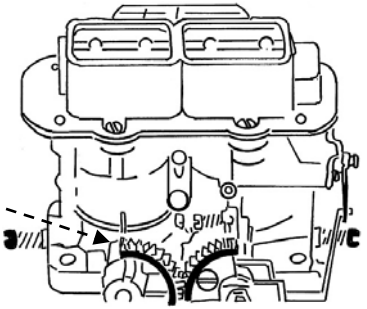

*DGAS models have two wider 38mm barrels which can be tuned separately*

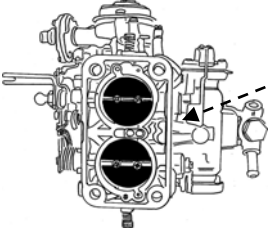

*Add #9029 and #9060 hardware adaptors*

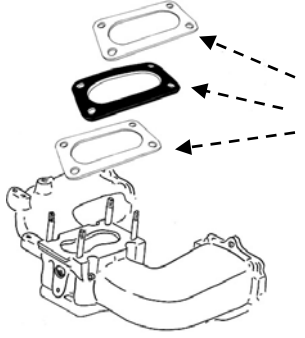

**9035**  
Mount Kit for DGAS

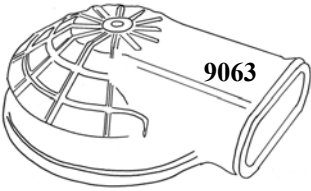

9063

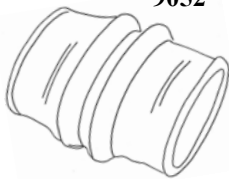

9052



9024K&N

*"Dome" kit provides underhood clearance and optimal filtration*

**Weber DGAS Carb & Hardware**

**9028 WEBER DGAS CARBURETOR**

High performance down draft with two 38mm barrels that work simultaneously using gear linkage. Bolts to original intake manifold and linkage with minor modification. Genuine, Trademarked and European-made Weber that features quality of manufacturing and design and ease of tuning. *Adds increased horsepower to a well-built engine (not recommended for original or low-compression Opel motors).* Best installed with #9029, #9060 & #9035 gasket set.

**9029 LINKAGE ADAPTOR BRACKET**

Special throttle linkage bracket, works with #9060. Minor modification required at mount, for a flush fit.

**9034W INTAKE MANIFOLD STUD KIT**

Special length for a better fit for Weber carburetor installations. Set of 4 new studs with nuts and washers, helps to prevent common vacuum leaks by securing carburetor to intake manifold.

**9035 GASKETS, DGAS WEBER CARBURETOR to INTAKE MANIFOLD**

Weber DGAS carburetor to Opel 1.9L intake manifold. Contains two thin gaskets and one spacer plate.

**9060 BALL NUT**

Ball nut that connects #9029 to stock throttle linkage.

**9063 WEBER SNORKEL "DOME" KIT**

Best option for performance installations such as a starting point for a custom DIY cold-air set-up. Also best for those who seek to draw in cooler air to resist carburetor heating issues, or to retain the stock appearance of a fender mounted air cleaner and connector boot. Can be fit to our #9052 hose.

**9024KN K&N AIR FILTER**

K&N High-Flow GT 1971-73 stock air filter element. Washable & Re-usable! Fits: Stock GT, Identify lid style of air filter canister to assure fitment.

**9052 CONNECTOR BOOT, for STOCK GT AIR CLEANER**

This is a ribbed rubber connector that fits between the stock GT air cleaner canister to the dome outlet.

**9091 VENTURI, 38-Size Weber**

**14019 WEBER CARBURETOR BOOK**

Explains DGV-Series, DGAS and other downdraft Weber carburetors. Over 180 pages.



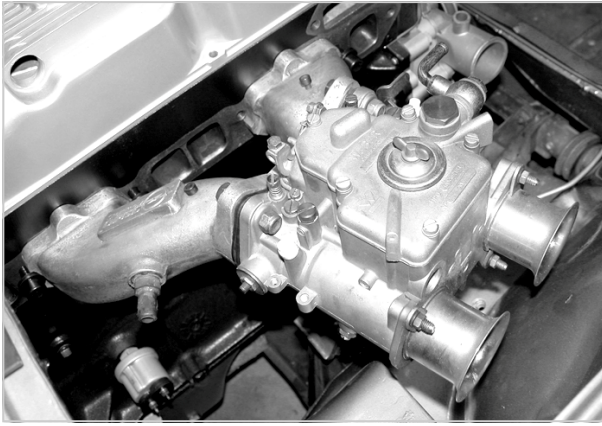

*Power Play: Side-Draft carburetors/manifolds offer 30%-50% power gains (plus potentials for even more)  
Above: Steinmetz SSD "angled" Opel GT manifold*

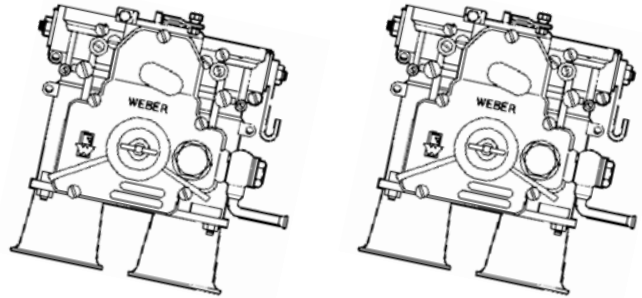

*DCOE Carburetors offer interchangeable venturis and jets, for more precise atomization and tuning*

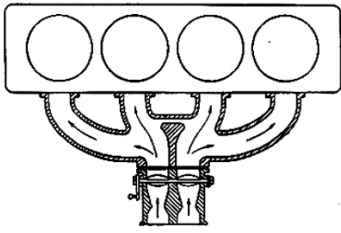

**Single Side Draft**

**9072**

*The "next step up" from downdraft 32/36 Webers*

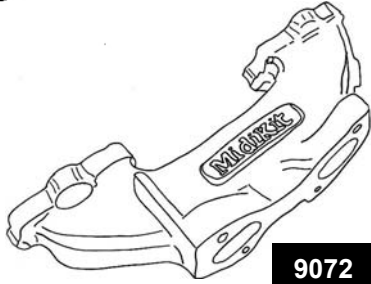

**Dual Side Drafts**

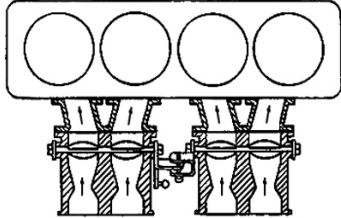

**9048**

*Highest-quantity of fuel delivery available from a bolt-on assembly*

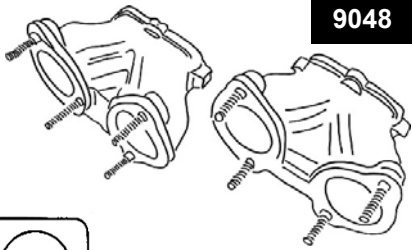

**Side Draft Carburetors and Hardware**

**9096 STEINMETZ SIDE DRAFT MANIFOLD**  
*Dramatic fuel upgrade for 1.9/2.0L CIH engines!  
Inquire for details. Exclusive import from OGTS.*

**9072 MIDI-KIT**  
Manifold for Single Side Draft Carburetor installation.  
Inquire for your application & #9072L linkage kits.

**9072L THROTTLE LINKAGE FOR MIDI-KIT**  
Designed for #9072 MIDI-KIT install on Opel GT.

**9048 2.2L-2.4L DUAL SIDE DRAFT MANIFOLDS**  
For 40 or 45 DCOE. Special order item.

**9065 DCOE SOFT MOUNT KIT**  
Fits 40 or 45 DCOE Side Draft carburetors.

**16003 THROTTLE CABLE MOUNT BRACKET**  
Throttle linkage converts to cable, using this at firewall

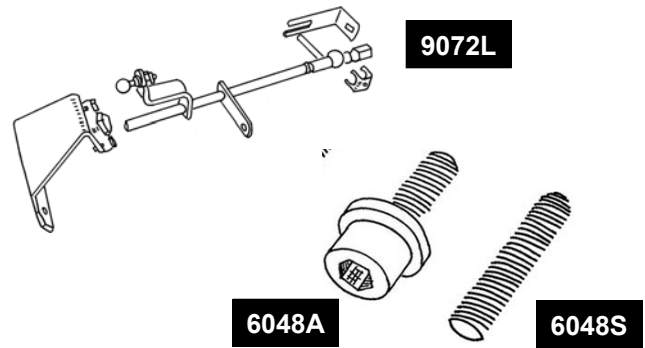

**6048A BOLT**  
Bolts intake/exhaust manifold to cylinder head. Allen Head Socket style, 9mm x 1.25 threads. Features original-style thick washer, makes tightening or removing original or special manifolds much easier. 6 required per cylinder head.

**6048S INTAKE/EXHAUST MANIFOLD STUD**  
Special Order custom-cut stud, for unique applications

## Fuel System Notes

Original Opel GT fuel systems now require maintenance and updated components for streetable performance, particularly when operating with modern pump fuel blends containing ethanol. A required safety procedure is inspection of all hardware connected to the fuel tank, including vent hoses located within the vehicle interior, to secure the driver & occupants from exposure to gas fumes.

### Original Solex Carburetors

These can run well and offer good fuel efficiency, when they have relatively low miles on them and are undamaged. However when Solexes have difficulty maintaining a consistent idle or start dumping gas internally, it is time to consider a replacement Weber.

### Weber Carburetors (European-Made)

Opel GT Source only offers for sale new European-made Weber carburetors as they have been proven for over 30 years to provide optimum tuning and performance results. We also offer a complete selection of hardware required for correct installations. We caution buyers about “lookalike” copies made somewhere in Asia, that do not carry a warranty from the Weber factory.

### Fuel System Operation

Classic Opel fuel systems also require maintenance of fuel tank-area hardware, and verification of adequate fuel pressure to the carburetor.

### Ethanol (Caution)

Modern fuel blends containing ethanol can affect your fuel system operation, including symptoms such as heat soak and fuel boiling.

*Consult our Opel fuel system notes online at: [www.opelgtsource.com](http://www.opelgtsource.com), for issues & remedies related to ethanol.*



### Gauge Markings

*Half = 7 gallons, Red = 1.75 gal  
Reading accuracy can vary  
with the condition of  
your tank sender and circuit.*

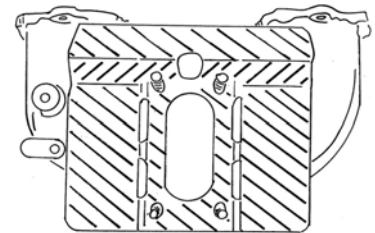

### Heat Shield

*Installation is now recommended  
to reduce effect of fuel boiling  
in carb (from ethanol)*

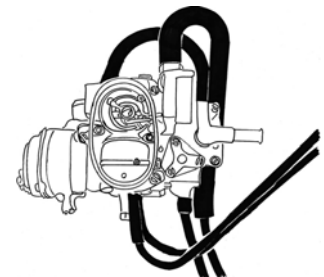

### Vapor Canister Hoses

*Original Solex carburetors  
required two additional hoses,  
which are removed when a  
Weber is installed.*



**9052 Air Filter Connector**  
Replace a cracked or missing connector with this rubber piece



**9063 Weber Dome Kit**  
Mounts on top of Weber Carburetor  
*Better breathing, nice appearance*

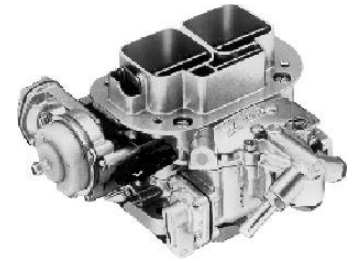

**9017 Weber DGV Carburetor**  
New European-Made w/Electric Choke  
*Contact us to discuss your application*

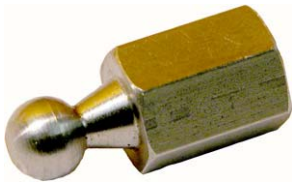

**9060 Ball Nut**  
Special deeper thread design  
*Best for Weber linkage conversion*



**9029 Weber Linkage Adapter**  
Required for use with original Opel throttle linkage with a Weber DGV  
*Helps ensure maximum acceleration*



**9003 Weber Air Filter Kit**  
*Higher-quality OEM-manufactured kit. Filter upgrade package includes 2 1/2" element, housing, gasket & hose adapter*



**9005 & 9006 Throttle Grommets**  
Secures linkage at pivot points  
*Reduces wear at carburetor bushings*



**9042 Fuel Filter**  
Clear see-through design  
*Provides easy fuel system inspection*

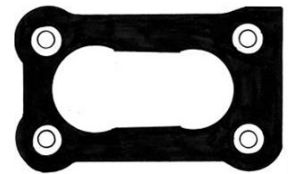

**9004 "Thick" Style Carb Gasket**  
Thicker style with reinforced "eyes"  
*Better heat insulation and vacuum leak resistance*



**Used Fuel System Parts available**  
*Contact Opel GT Source with your needs*  
[opelgts@opelgtsource.com](mailto:opelgts@opelgtsource.com)

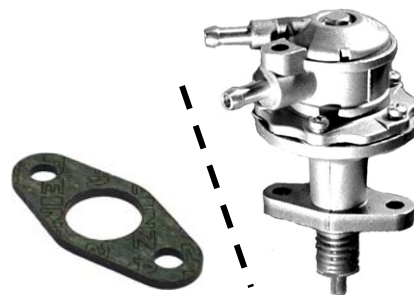

**9010 & 6051 Fuel Pump & Spacer**  
Heavier- Duty version  
*Install notes available*



**9034 Intake Stud Kit**  
4 studs per kit  
*Choose Weber or Solex length*

# 10000/Exhaust System







An extensive inventory of the original exhaust parts and installation hardware

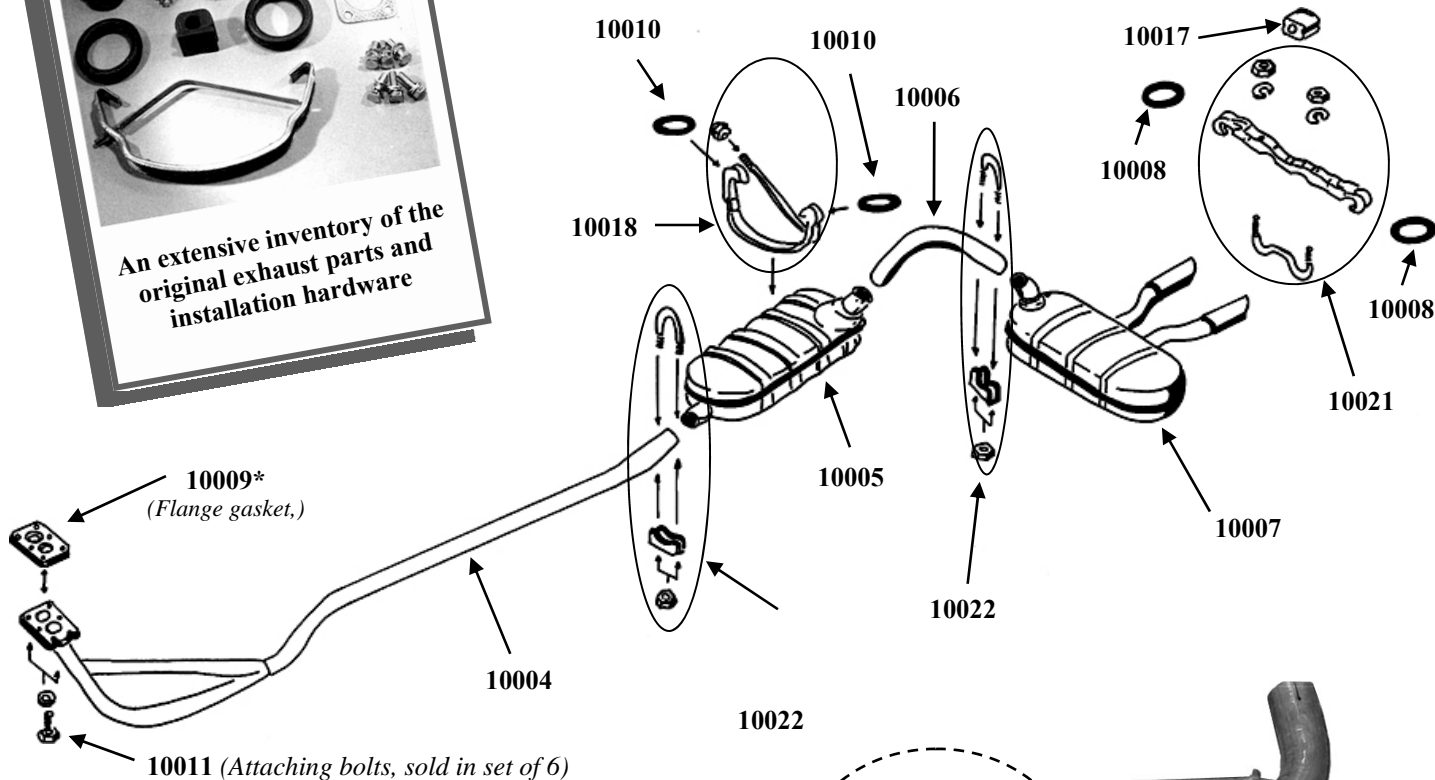

**“Chrome Tip”  
design**  
Illustrates  
chromed tips  
on # 10007  
resonator



### GT Exhaust System, Original Style

**10004 HEAD PIPE, 1.9L GT**  
Connects exhaust manifold to front muffler.

**10005 FRONT MUFFLER**  
Located at the end of the head pipe, just before the rear axle. Installs with #10018 hanger bracket and #10010 hangers.

**10006 CONNECTOR PIPE**  
Connects front muffler to rear resonator.

**10007 RESONATOR**  
Located at rear of the GT. Visible w/twin chrome tips.  
*Contact OGTS for info on current supplier designs.*

**10009 GASKET, EXHAUST FLANGE**  
Original manifold to headpipe.  
About 61mm x 122mm with 42mm ports  
Note: If using European-design "Sprint" manifold, see #10016, #10019 or #10019A.

**10011 BOLTS**  
Headpipe to exhaust manifold. Set of six (6).

### GT Exhaust System, Upgrade

**10029 STAINLESS STEEL EXHAUST KIT**  
Contact OGTS for details & to discuss your application.

### GT Exhaust System Hardware

**10008 HANGERS, RUBBER**  
Specially designed for rear resonator only. Provides extra strength and tension to steady rear resonator.

**10010 MUFFLER DONUTS**  
Fits #10005 front muffler with #100018 bracket.

**10017 RESONATOR BUMP STOP BUSHING**  
Located on the GT floor board between the resonator mounting hooks

**10018 HANGER BRACKET**  
Wraps around front muffler with hooks for #10010

**10021 REAR RESONATOR HANGER BRACKET**  
European reproduction bracket for use with the rear resonator.

**10022 MUFFLER CLAMP**

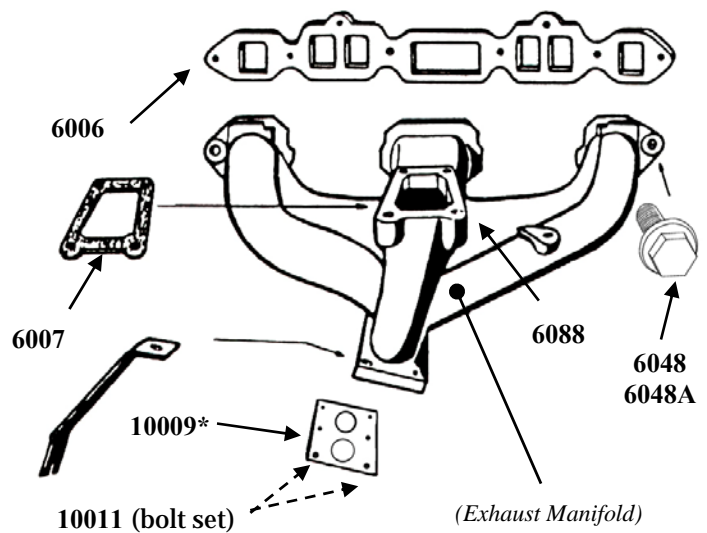
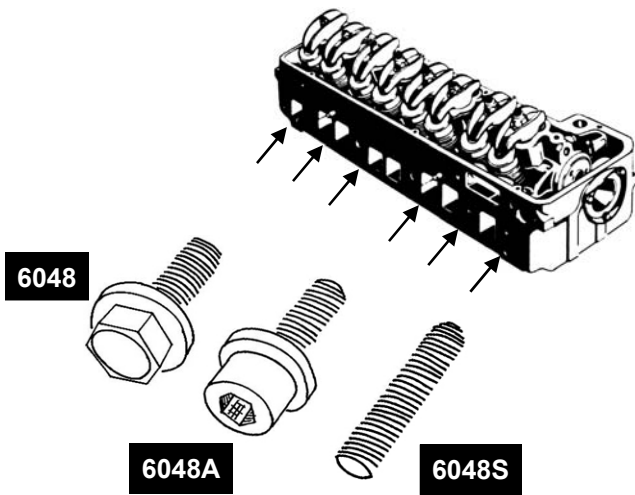

### Exhaust Manifold Hardware

#### 6006 INTAKE/EXHAUST GASKET

Intake/exhaust to cylinder head gasket, for 2.0L. Also fits 1.5L & 1.9L.

*(Note: See #10012/#10012A if you install headers)*

#### 6007 EXHAUST TO INTAKE GASKET

Fits between the intake and exhaust manifolds (the square, "hot spot" area gasket), 1.9L.

#### 6048 BOLT

Bolts intake/exhaust manifold to cylinder head. New production. Six (6) required.

#### 6048A BOLT

Bolts intake/exhaust manifold to cylinder head. Special Allen-Head design. Ideal for side draft carbs. Six (6) required. (We also offer #6048S studs)

#### 6048S INTAKE STUDS

Special Order, Custom Length cut, *inquire for details*

#### 6088 BOLT WITH SERRATED 8MM HEAD

Intake manifold to exhaust manifold. Four (4) req..

#### 10009 GASKET, EXHAUST FLANGE

Original manifold to headpipe.

About 61mm x 122mm with 42mm ports

*Note: If using European-design "Sprint" manifold, see #10016, #10019 or #10019A.*

#### 10011 BOLTS

Exhaust manifold to head pipe. Set of six (6).

#### 10016 GASKET

Euro 2.0L-2.4L exhaust flange. 61mm x 12mm O.D.

#### 10019 GASKET

Fits 2.0 exhaust flange for English fuel injection exhaust manifold. Composite gasket 3" x 5.5" O.D.

#### 10019A GASKET

Metal Gasket for Euro 2.4L, 76mm x 140.5mm O.D.

#### 12013 8mm SERRATED TOOL

Fits original intake manifold to exhaust assembly bolts.

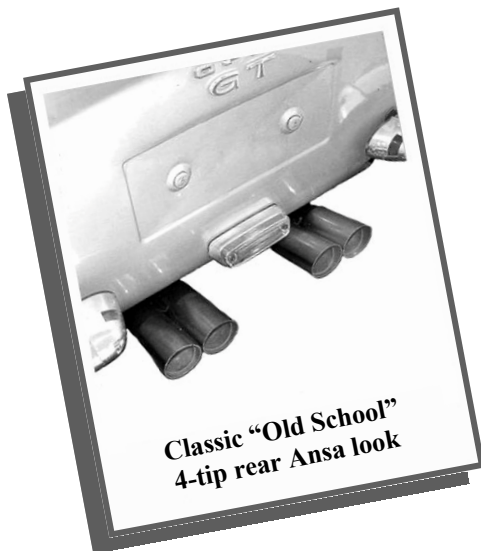

Classic "Old School"  
4-tip rear Ansa look



### ANSA 4-Tip Resonator

#### 10025 ANSA 4-TIP REAR RESONATOR

Special production. *Contact us for availability*

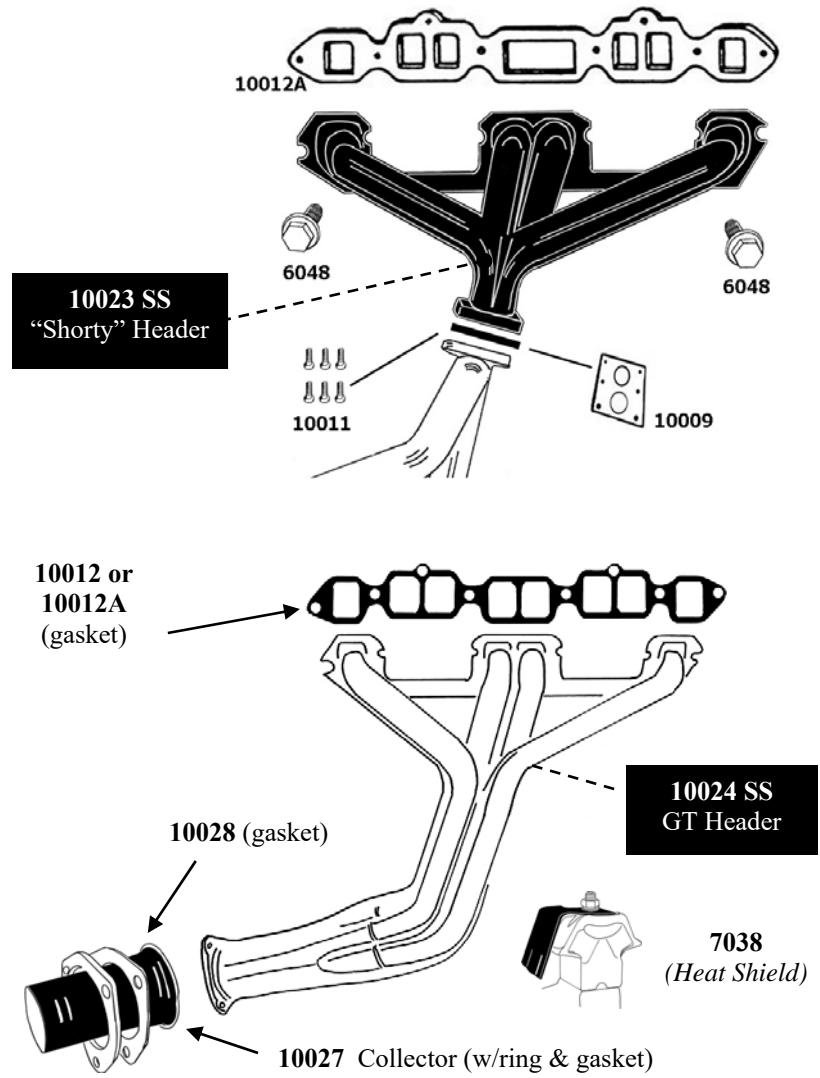
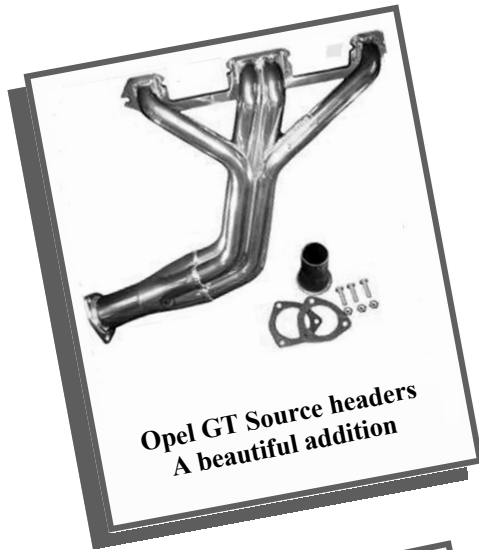

**Headers & Hardware**

**10023SS OPEL "SHORTY" HEADER**

New stainless steel header, a bolt-on which fits all 1968-1975 Opel GT/Manta/Ascona/Kadett models with 1.9L engines.

Designed to replace original exhaust manifolds, to better separate the intake manifold and carburetor from exhaust heat, for more reliable performance when driving using ethanol-blended fuel. Best when installed with our #10012A & #10009 gaskets and #6048 bolts. *Additional details are on the Opel GT Source website*

**10024SS OPEL GT "LONG TUBE" HEADER**

A new polished longer-tube stainless steel header that will fit Opel GT's with 1.9, 2.0, 2.2, 2.4 CIH engines.

A 4 into 1 design header provides improved appearance and performance - great quality at a great price! Best when installed using our #10012 gasket and #6048 replacement manifold bolts. *(This header replaces #10023 & #10024 in our inventory)* *Additional details are online, at the Opel GT Source website and on the OGTS Facebook site.*

**10012 CRUSH-FIT HEADER GASKET, 1.9 - 2.0L**

Top quality crush-fit material provides optimal sealing of headers at the critical flange-to-cylinder head area, recommended for higher-performance applications.

**10012A MANIFOLD GASKET, THIN STYLE**

New lower-cost thin design, for installation of headers on 1.9/2.0 cyl heads. Recommended with #10023SS

**6139 HEADER GASKET, 2.2-2.4L**

Thicker crush-fit material, fits header to unique intake/exhaust port layout of the 2.2L - 2.4L cylinder heads.

**7038 HEAT SHIELD**

Fits above motor mount on GT passenger side

**10027 HEADER COLLECTOR RING & GASKET**

2 3/4" O.D., 2" I.D., with Ring and 2 1/2" I.D. Gasket

**10028 HEADER LOWER GASKET**

2 1/2" I.D.

## Exhaust System Notes

The original Opel GT exhaust system requires inspection and maintenance, to identify rust and other common issues.

Opel GT Source offers replacement parts for original-design exhaust systems, as well as upgraded components to complement higher-performance engine builds.

### Proper Installation

The Opel GT exhaust system requires secure mounting so that it resonates as a singular assembly. Having an exhaust professional modify pipe joint angles and adding small spot/bead welds, can help ensure longevity and proper function of system components.

### Exhaust Manifold Bolts

Prior to separating the head pipe from the manifold, spray connecting bolts with WD-40 or a similar penetrating oil daily, then use a 13mm flex-head socket to reach and detach bolts. Another approach is to consider grinding the bolt heads down.

### GT Exhaust Header

A header will not only improve your under-hood appearance but will also help enhance high-rpm flow from performance-built engines.

### Larger Exhaust Systems

Performance-built Opel engines also benefit greatly, with installation of 2" diameter exhaust system coupled with a header.

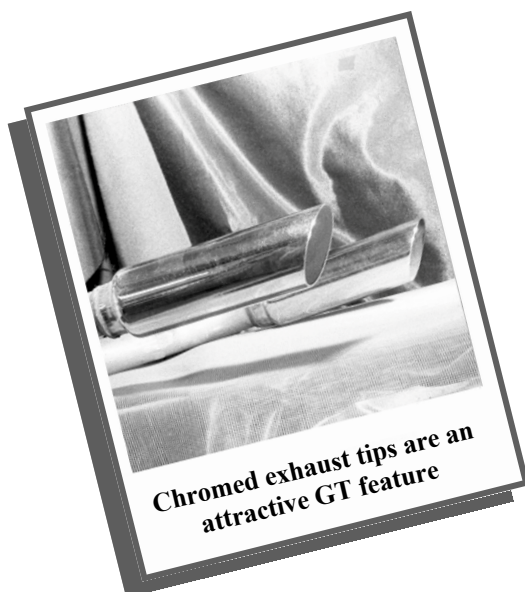

**Larger Systems**  
Contact us for details

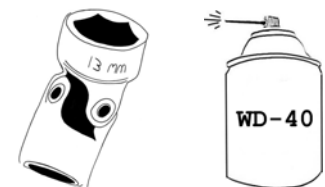
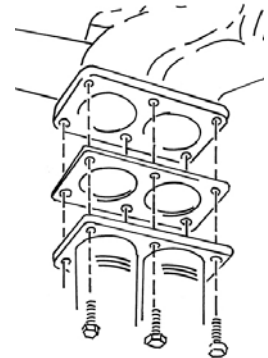

### **Exhaust Manifold Bolts**

*Attaching bolts here can be difficult to remove. Spray frequently with penetrating oil for days before you start, and reach with a 13mm flex-head socket, to avoid snapping.*

*Another approach to consider is machining down bolt heads to separate parts, then reinstalling with metric studs and nuts.*

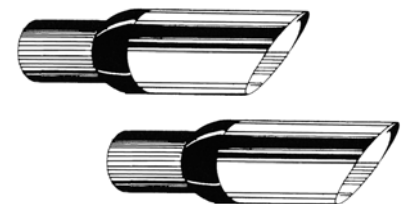

### **Wider Tips**

*Aftermarket styles can be obtained from various suppliers.*





**10011 Bolt Set**  
Fits Head Pipe at Exhaust Manifold  
*Set of 6 bolts plus washers*



**10012A Manifold Gasket**  
New upgraded material  
*Fits header at a new lower price*



**10023SS "Shorty" Header**  
Fits all 1968-1975 1.9L Opel models  
*Stainless steel, better drivability  
See website for more details*



**10008 Resonator Hanger**  
New Reproduction  
*For GT rear resonator*



**10024SS GT Header, Stainless Steel**  
New production, helps provide superior output from GT engines  
*Beautiful under-hood appearance, at a new lower price!*



**10010 Muffler Hanger**  
New Rubber Donut  
*Fits GT Center Muffler Support Bracket*



**10009 Exhaust Flange Gasket**  
Fits Head Pipe to Exhaust Manifold  
Connection. Standard 1.9L size.



**Used Exhaust Parts also available**  
Contact Opel GT Source with your needs  
[opelgts@opelgtsource.com](mailto:opelgts@opelgtsource.com)



**10021 GT Resonator Hanger**  
New Reproduction Design  
*Fits new "big tip" style resonators*



**10029 STAINLESS STEEL  
EXHAUST SYSTEM KIT**  
New Reproduction fits Opel GT  
Contact OGTS for details and to discuss  
your particular drivetrain application.

# 11000/Cooling System

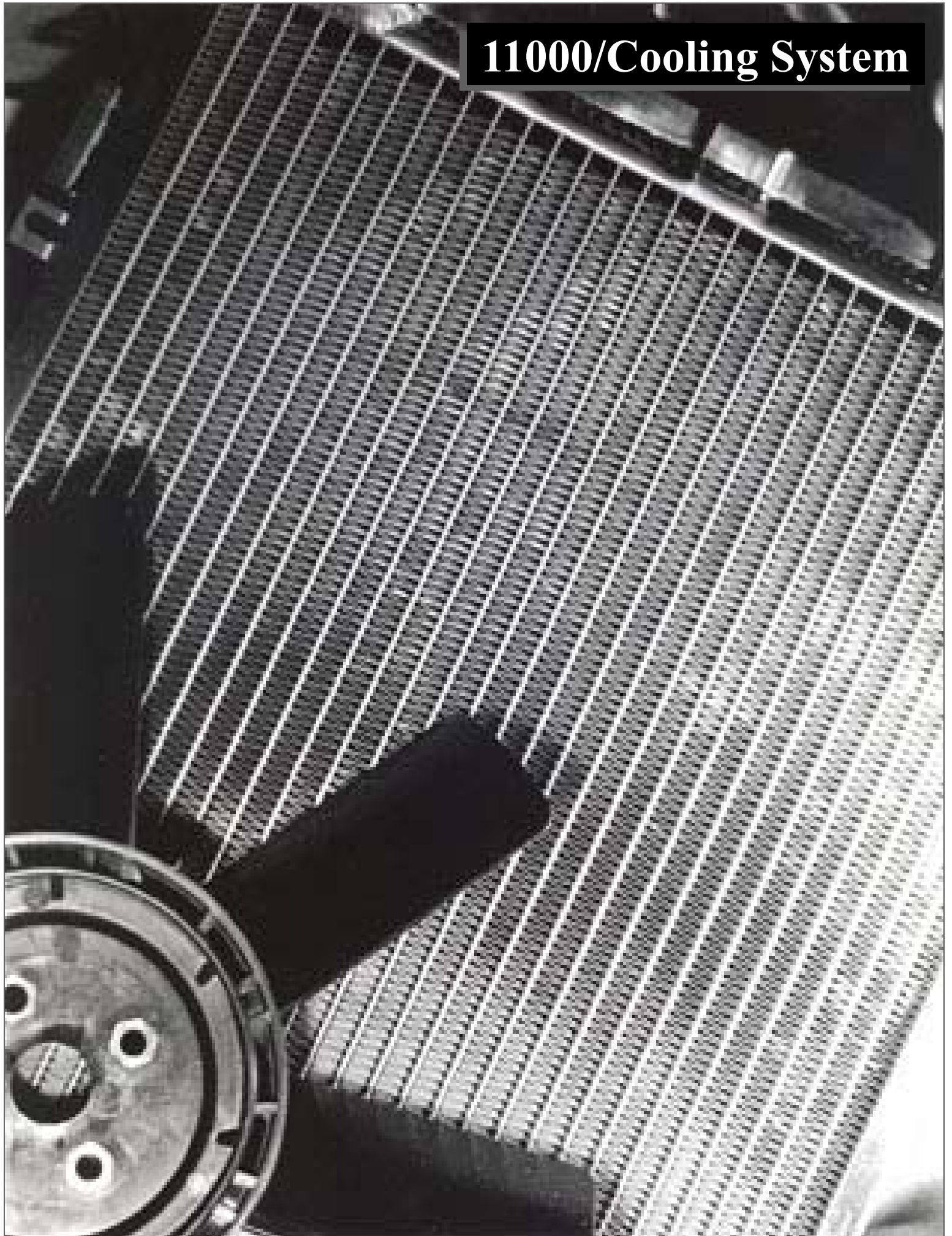

## Radiator Hardware

### 11001 UPPER RADIATOR HOSE, GT

Fresh rubber hose connects thermostat to radiator. This is a custom-formed hose, that gives you an optimal fit and won't get restricted when installed.

### 11002 LOWER RADIATOR HOSE, GT

Fresh rubber hose to fit water pump to radiator. This is a custom-formed hose, that gives you an optimal fit and won't get restricted when installed.

### 11008 LOWER RADIATOR MOUNT

Small rubber bushing with correct stud threads.

### 11020 RADIATOR CAP

Holds pressure in cooling system. A sometimes-overlooked source of cooling system problems. Aftermarket.

### 11020A OEM STYLE RADIATOR CAP

Original type.

### 11035 RADIATOR SIDE MOUNT BUSHINGS

New reproduction items. Set of 2. Rubber. Water Pump and Fan Hardware

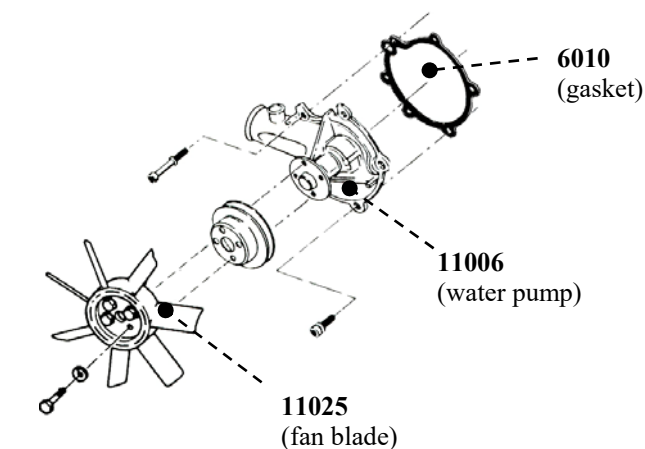
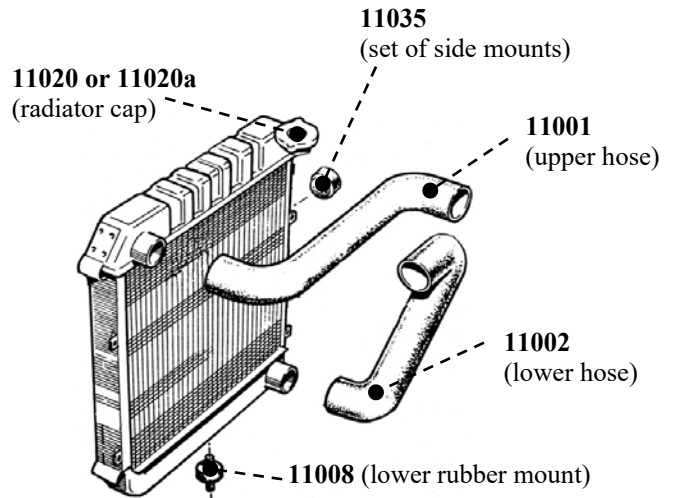

## Fan Blade & Related

### 11025 FAN BLADE

Replace your heat-warped, damaged or out-of-balance old fan today & enjoy superior cooling of a new fan. Faithful reproduction of original 7-blade Opel style.

### 11013 FAN BELT

To water pump, alternator and front crank pulley. 1.9L. Specify your application for correct length (refer to our print-version "part list" for Identification/application details)

### 6047 LOWER ALTERNATOR BUSHING

Extends life of alternator, water pump and other engine front hardware by dampening vibrations. Two (2) required.

### 6049 UPPER ALTERNATOR BUSHING KIT

Between bracket and timing cover. Set of two (2).

## Water Pumps and Higher RPM's

*The narrow Opel pulley causes components to rotate at higher RPM's than other vehicles, which results in cavitation within the lower rad hose (and we've seen cheap-style pumps fail quite suddenly on the road).*

To avoid this sort of issue, shake the center of the fan blade as part of regular maintenance, and replace whenever you feel looseness there (or whenever you rebuild an engine). A quality water pump can be your "insurance" for worry-free road trips in your future!

## Water Pump

### 11006 WATER PUMP

All new higher-quality "closed impeller" design, includes #6010 mount gasket, fits 1.9L engines.

### 6010 GASKET

Required gasket, fits water pump to timing cover.

### 6168 BOLT SET FOR WATER PUMP

Set of 6 new bolts to better secure water pump to timing cover on Opel CIH 4-cylinder engines,

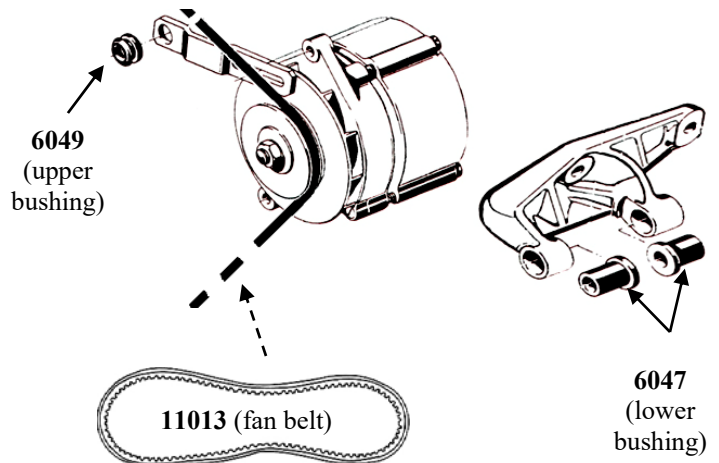

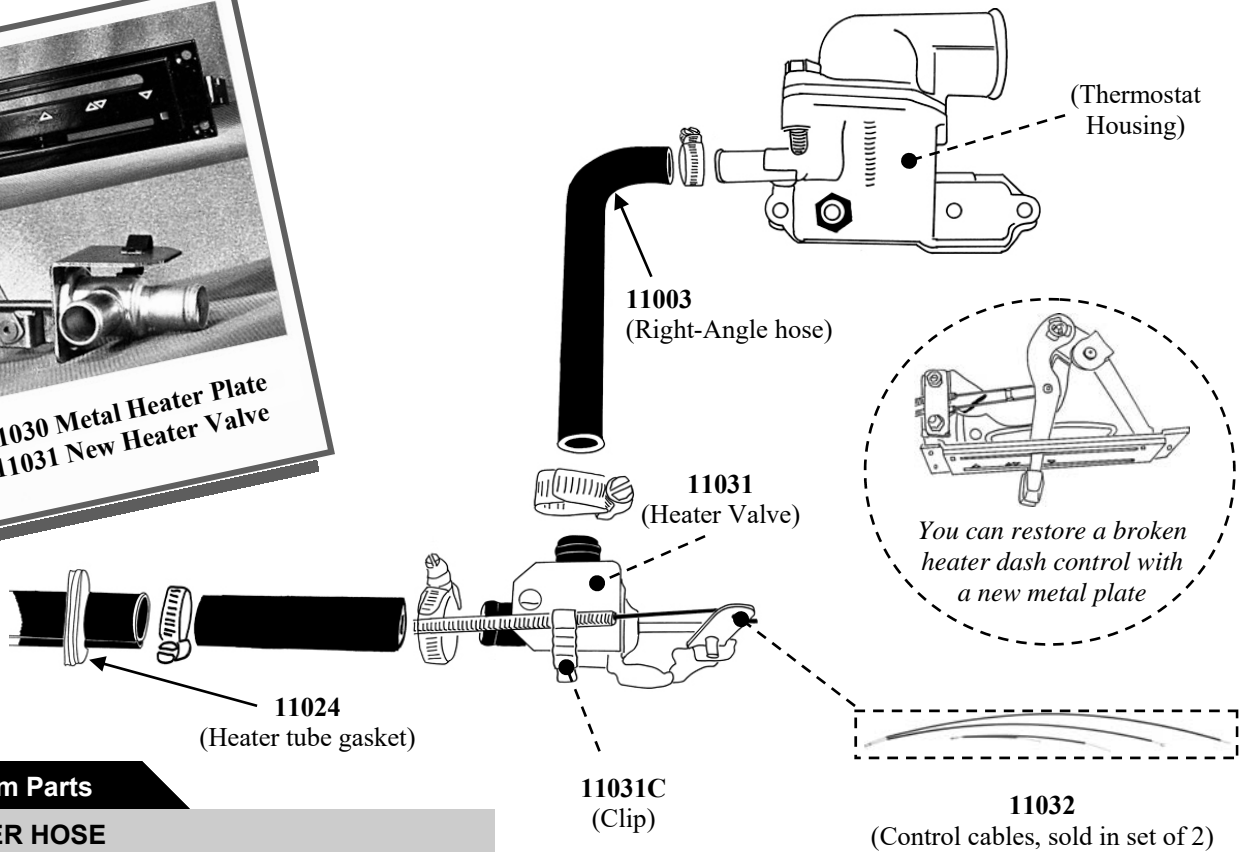

### Heater System Parts

#### 11003 HEATER HOSE

Includes formed 90 degree curve, connects from thermostat housing to heater valve. Helps avoid pre-heating at the carburetor by keeping hot fluid hose distanced from front of housing of the carburetor

#### 11024 GASKET

Heater box tubes to chassis. Rubber.

#### 11030 HEATER CONTROL PLATE

Metal reproduction. Very high quality. A must for any GT. Replaces the typically-broken original plastic control, which in almost all cases becomes inoperable when it separates at the rear cable hardware mount, and re-uses your existing hardware. Your existing levers and cables easily transfer to this new plate.

#### 11031 HEATER CONTROL VALVE

Replace your sticking, leaking or clogged original valve with this new reproduction GT heater valve for better controlled heater operation.

#### 11031C HEATER CONTROL VALVE CLIP

Clip holds cable sheath to #11031 valve

#### 11032 HEATER CONTROL CABLES

NEW, dual heater control cables for your Opel GT. Replace your sticky/rusted cables with these brand new cables today.

### Thermostat & Hardware

#### 11005 THERMOSTAT

Specify 160 degrees (recommended for high-temp Summer driving or high-performance conditions) or choose 180 degrees (lower temp or Winter uses).

#### 6013 GASKET

Surrounds thermostat in housing.

#### 6014 GASKET

Fits between thermostat housing and cylinder head. Universal design fits both 2-bolt & 3-bolt housing style

#### 11009 TEMPERATURE SENDER UNIT

OEM replacement for 13mm sender found in 1970-1973 GT housing. (Will not fit 1968-1969 17mm style)

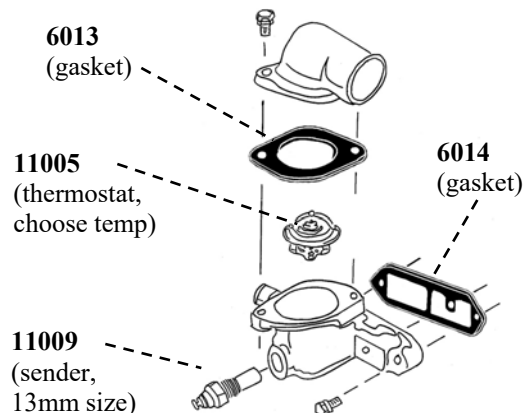



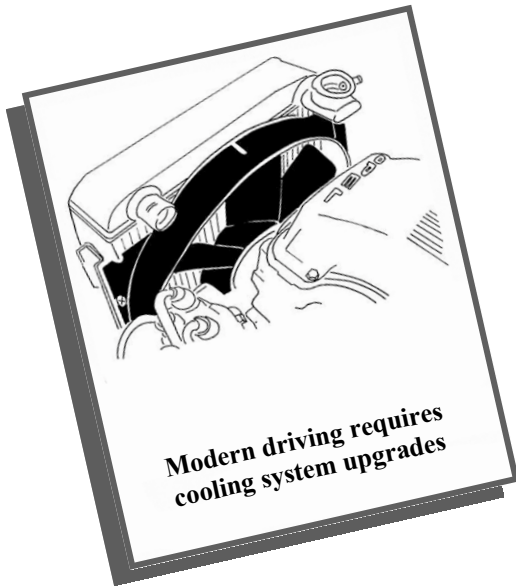

11023A

**Cooling Systems and Your Opel GT**

*Original Opel GT cooling systems are now inadequate to handle demands of driving conditions in warmer climates, and now require upgrades to perform alongside modern cars.*

Our newest user-friendly upgrade is installation of our all-new GT aluminum radiator into a manual transmission GT. This unit resists rust and corrosion, and has been road-proven to meet cooling requirements for original and upgraded engines.

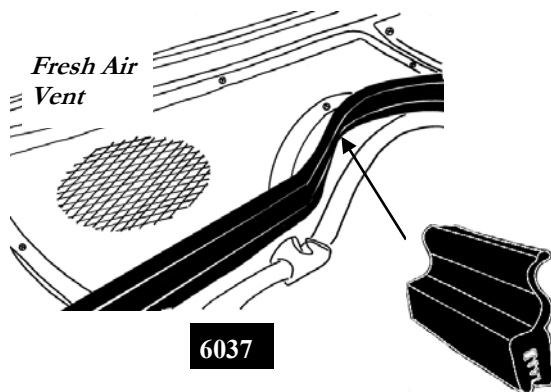

6037

*Convenient, low-cost upgrade*  
*Install our #6037 under-hood rubber strip set for directed airflow*



12122

11026

11023A

**Cooling System Upgrades**

**6037 UNDERHOOD WEATHERSTRIP KIT**

Set of 4 rubber strips help direct under hood airflow through the fins of the radiator. Sturdier design also helps keep engine fumes from entering the cars interior through the air vents.

**11016C HEAVY DUTY RADIATOR CORE**

High density, 3-row dimpled tube copper/brass core, allows you to save money by having your radiator rebuilt at a local shop. Retains original Opel system pressures for better protection of critical internal engine seals. *Special Order item Subject to availability*

**12122 WATER WETTER ADDITIVE**

Coolant additive, a surfactant that help get the most performance out of an original cooling system. 12oz bottle. Offered as a convenience item.

**11023A ALUMINUM OPEL GT RADIATOR**

**A special new production from Opel GT Source!**

All-aluminum to avoid rust and resist corrosion

Designed for compatibility both with original and performance-upgraded Opel engines, it is a bolt-on for manual transmission GT's, and adds a drain plug!

*Note: A slightly stronger anti-freeze mix is required.*

**11026 FAN SHROUD**

Helps concentrate airflow through your radiator. Recommended when Summertime driving routinely causes the temperature gauge to exceed the halfway mark. *Requires good condition motor and transmission mounts & brackets as well as some minor adjustment during final assembly.*

## Cooling System & Heater Notes

Cooling system maintenance and performance is important for engine operation and durability. Optimum performance for carbureted engines is to run at about 185F. Sustained operation at temperatures above 212F adds a significant risk of internal engine warpage (particularly on engines with 1973-74 "12-bolt" style cylinder heads).

### Cooling System Maintenance

Important maintenance includes back-flushing out cooling system (including the heater core) and regular replacement of critical wear items (like hoses, gaskets, fan belt, fan blade, water pump, alternator bushings, heater valve), and installation of a dash-mounted metal heater control.

### Coolant

We suggest running original Opels with a 50/50 mixture of standard coolant (or a higher % with our aluminum radiator), and to change the thermostat seasonally when an Opel is operated year-round.

### Fan Belt

Proper fan belt tension (1/2" flex at mid-point of its stretch), prompt replacement of damaged fan blades, and installation of new alternator bushings, will increase longevity of Opel water pumps. To select the correct fan belt for your Opel, you need to identify the length and style of the alternator mount brackets that you have. It's a very good idea to also carry an extra fan belt, as well as spare hoses, cooling system gaskets and a water pump with you in the car, particularly if you are planning an extended-length road trip.

### Cooling System Upgrades

Opel GT owners in warmer climates, or those who have installed a higher-performance engines, may benefit from additional part upgrades to keep their GT's running cool.

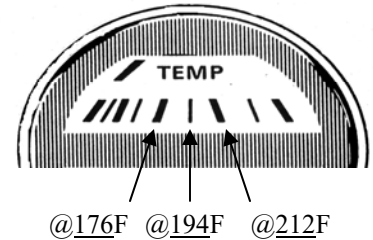

### Temperature Readings

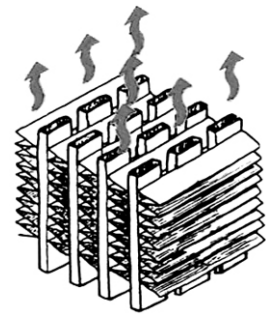

### Radiator Upgrades

We recommend our all-new Aluminum GT radiator for most street-driven GT's. Contact us to discuss yours.

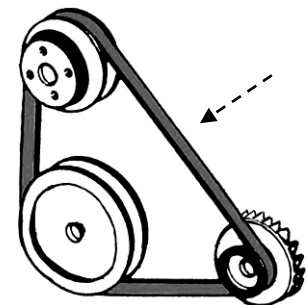

### Fan Belt Adjustment

Tighten to a 1/2" deflection, halfway between the upper fan pulley and the alternator pulley



**11024 GT Heater Tube Gasket**

New, Fits underhood heater tubes  
*Helps keep engine fumes out of interior*



**11025 Fan Blade**

*New 7-Blade Black Plastic*  
Fits GT, Kadett 1.9L, Manta 1971-74



**11023A GT Aluminum Radiator**

Superior Cooling for a Lower Cost!

*Now recommended for most street-driven GT's, particularly for warm-climate & Summer cruising.*

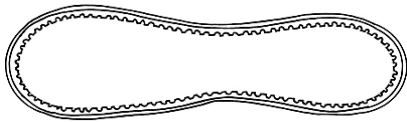

**11013 Fan Belt**

*Specify your hardware styles for correct installation*



**11006 Water Pump**

All-new reproduction. Includes a gasket!  
*Improved impeller for superior cooling*



**11032 GT Heater Cable set**

New Reproduction  
*Replaces stuck or broken cables*



**11035 GT Radiator Side Bushings**

New RubberDesign  
*New reproductions stabilize radiator*



**11030 GT Heater Control Plate**

New All-Metal Reproduction  
*Replaces typically-broken original plate*



**Used Cooling System Parts**

Contact Opel GT Source with your needs  
[opelgts@opelgts.com](mailto:opelgts@opelgts.com)



**11031 GT Heater Valve**

New Reproduction in metal  
*Original design, includes cable clip*



**11002 GT Lower Radiator Hose**

New Reproduction for Opel GT  
*Formed design to clear GT fan & shroud*

# 12000/Accessories





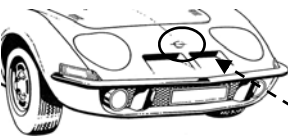



**Front GT Emblem**



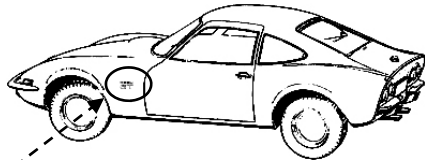

**Front GT Emblem**  
 "Blitz" Insignia  
 (#12001 & Grommets)  
*Originally on nose panel of all GT's*

**Side GT Emblems**

**Front Side GT Fender Emblems**  
 "OPEL" Plate & "GT" letters  
 (#12002, #12004 & Grommets)  
*Originally on both sides of 1968-1970 GT's*

**Rear GT Emblems**

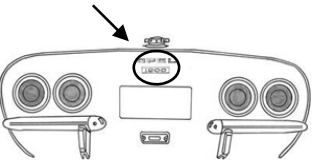
"O-P-E-L" Letters & "1900" plate  
 (#12003, #12006 & Grommets)  
*Originally on 1968-1970 GT's*

**Rear GT Emblems**

"O-P-E-L" Letters & "GT" letters  
 (#12003, #12004 & Grommets)  
*Originally on 1971-1973 GT's*

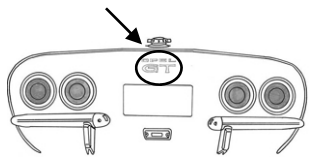
**Body Emblems & Related**

**12001 BLITZ EMBLEM, OPEL GT FRONT**  
 Front "Blitz" emblem used on all Opel GTs from 1968 thru 1973. Chromed Plastic reproduction replica

**12001B BLITZ EMBLEM, OPEL GT/J FRONT**  
 Black version of front emblem used on the European Opel GT/J model. Black Plastic reproduction replica

**12002 EMBLEM PLATE "OPEL"**  
 GT located on side front driver and passenger front fenders. One emblem per front fender required. For 1968, 1969 & 1970.

**12003 EMBLEM SET OPEL**  
 "O" "P" "E" "L" emblem set. These emblem letters are located on the tail lamp panel of all 1968-1973 Opel GT Chromed Reproduction.

**12004 EMBLEM SET GT**  
 "G" "T" emblem set. Chromed Reproduction.  
**ORDERING TIP:**  
 1968-1970 GT one (1) emblem set per front fender.  
 1971-1973 used one (1) emblem set on the rear tail panel.

**12006 EMBLEM PLATE 1900**  
 "1900" emblem plate. Used on 1968, 1969 & 1970 GT, which denotes this GT has a 1.9L engine. Located on the rear tail lamp panel. Red paint on flat-back metal

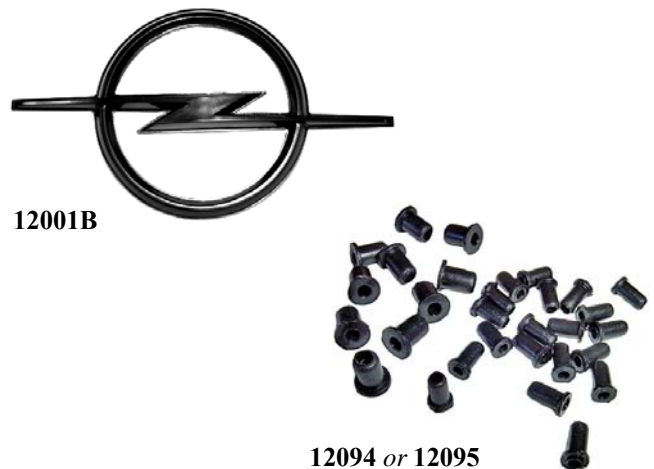

**12094 EMBLEM GROMMET SET, GT 1968-70**  
 Emblem grommet set for the 1968 thru 1970 model Opel GTs. These grommets press into the body to secure the exterior emblems. Commonly needed after a paint job or body repair work.

**12095 EMBLEM GROMMET SET, GT 1971-73**  
 Emblem grommet set for the 1971 thru 1973 model Opel GTs. These grommets press into the body to secure the exterior emblems. Commonly needed after a paint job or body repair work.

## Key Blanks & Keychain

### 12037A KEY BLANK

Fits some GT doors & ignitions. Buy extras for spares.

### 12037B KEY BLANK

Fits most GT gas caps, some GT doors and ignitions. A good idea is to also buy extras for spares.

### 12021 GT COUPE KEY CHAIN

Silver plated appearance

### 12036 OPEL KEY CHAIN

Includes famous "Blitz" logo for easier identification



Use above diagram to match up your key, to identify which blank style you require



12036

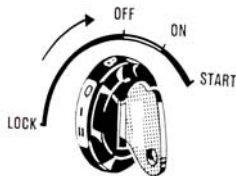

12037A or 12037B

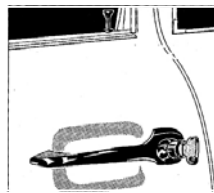

12037A or 12037B



12037B

## Models & Videos

### 12054 OPEL GT VIDEO

European Opel GT meetings, many to choose from

### 12054DVD DVD DISC

"Driving the Dream" DVD (with subtitles)  
Best viewed on a personal computer or laptop screen

### 12070 VITESSE OPEL GT/J 1:43 SCALE MODEL

Various versions, see Opel GT Source website for photos

### 12075R OPEL GT 1:24 SCALE MODEL

New AMT plastic model kit, Scale 1:24th

### 12075GT OPEL GT 1:24 SCALE MODEL

Special Opel GT Source version from AMT, Builds 3 ways.



12075R



12075

## Decals & Related

### 12097 TIRE SIZE STICKER

Door jamb decal, indicates pressure and load limits  
Red print on white background.

### 12098 GT TOWING EYE LABEL

Door jamb decal,  
Black print on silver surface.

### 12111 TIRE JACKING INSTRUCTIONS

Spare tire area decal.  
Red print on yellow background

Your Opel GT is provided with a towing "eye" at left-hand side of front bumper.

(Towing Eye decal)  
12098

VEHICLE LOAD LIMIT = 550 LBS.  
2 OCCUPANTS (2 FRONT AND 250 LBS. LUGGAGE)

MINIMUM TIRE SIZE  
OPEL GT-165 x 13.4-PLY RATING  
TIRE INFLATION PRESSURE  
RECOMMENDED FOR ALL LOADS  
(550 LBS. MAX.)

FRONT	REAR
19 PSI COLD	23 PSI COLD
25 PSI HOT	29 PSI HOT

SEE OWNERS MANUAL FOR ADDITIONAL INFORMATION  
08 955 918

(Door Jamb decal)

12097



(Tire Jacking decal) 12011

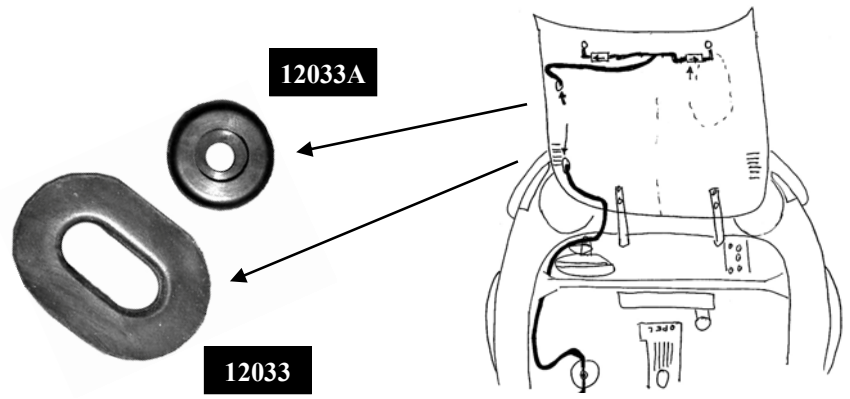

Hood Grommets

*New rubber secures washer tubing at entrances within hood*

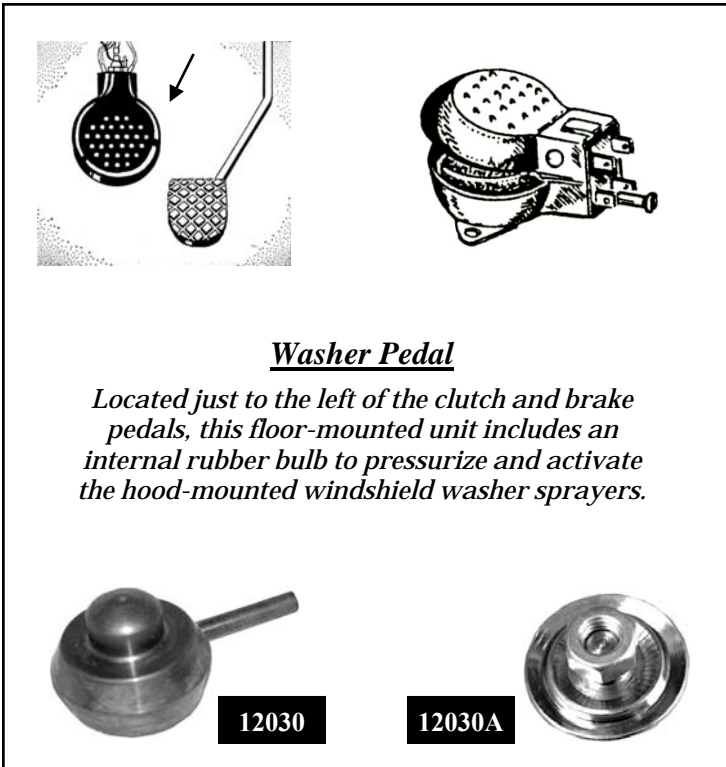

Washer Pedal

*Located just to the left of the clutch and brake pedals, this floor-mounted unit includes an internal rubber bulb to pressurize and activate the hood-mounted windshield washer sprayers.*



Washer Hardware

*Reproduction hardware includes sprayers, inline valves, tubing and a tank.*

**Window Washer Hardware**

**12028 WINDOW WASHER TUBING**  
One set does one GT, cut to fit

**12029 WASHER NOZZLE**  
Replacement design, Sold individually, 2 req. per car

**12030 RUBBER BULB**  
Fits inside original GT foot pedal

**12030A MOUNT STUD**  
Replaces typically rusted original stud, located within original foot pedal rubber bulb

**12028C CLIP FOR WASHER TUBING**  
Helps retain washer tubing in place

**12032 ONE-WAY WASHER VALVE**  
Fits inline to washer valves, you can choose to install either one or two valves per car

**12033 GROMMET**  
Fits larger opening, where washer hose enters hood

**12033A GROMMET**  
Fits smaller opening, where hose leaves hood to valves

**12034 WASHER TANK**  
New plastic reproduction.

## Specialty Tools

### 12012 SERRATED TOOL, 6mm

Fits early model fuel pumps & some engine bolts  
*Offered as a convenience item.*

### 12013 SERRATED TOOL, 8mm

Fits some engine, steering and manifold assembly bolts. *Offered as a convenience item.*

### 12014 SERRATED TOOL, 10mm

Fits brake system bolts. *Offered as a convenience item.*

### 12015 SERRATED TOOL, 12mm

Fits some engine bolts. *Offered as a convenience item.*

### 12016 COMPLETE SET

All four serrated tools listed above (6, 8, 10, 12mm)  
*Offered as a convenience item.*

### 12110 STEERING WHEEL HUB PULLER KIT

Includes unique-shaped removal bits.

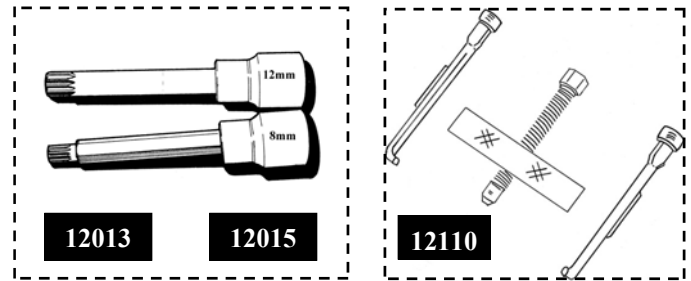

### 12013-S SERRATED TOOL, "Shorty" 8mm

Shorter version, socket base, helps turn camshaft bolts

### 12015-S SERRATED TOOL, "Shorty" 12mm

Shorter version, socket base, better access to that hard-to-reach rear cylinder head bolt on Opel GT's

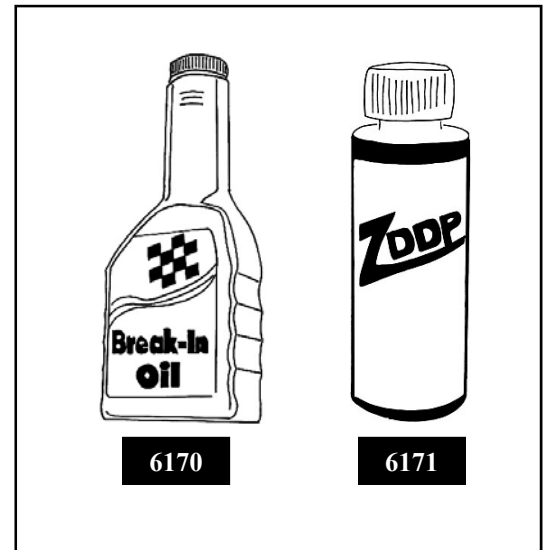
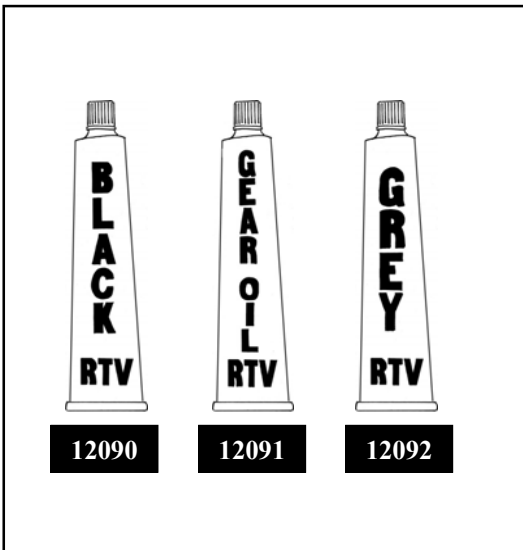

## Gasket Sealers & Additives

### 6170 ENGINE BREAK-IN ADDITIVE (12 oz. bottle)

Required when a new camshaft or lifters are broken in

### 6171 ZDDP ADDITIVE (4oz. Bottle)

Required whenever conventional motor oil is changed.  
Help prevent premature camshaft failure.

### 12017c "HIGH TACK" (4oz. Can)

Recommended for carburetor mounting and some engine hardware applications. *Convenience Item*

### 12022 THREADLOCKER (.02oz Blue, Sample size)

### 12090 RTV/SILICONE "BLACK" (3.35 oz. tube)

Recommended for some engine assembly applications.  
*Offered as a convenience item.*

### 12091 RTV/SILICONE "GEAR OIL SEALER"

Recommended for manual transmission and rear axle gasket applications. 3oz tube. *Convenience Item*

### 12092 RTV/SILICONE "GREY"

Special "high-torque" sealer. 3.5oz tube.

### 12120 LEAD SUBSTITUTE (12 oz. bottle)

Required with unleaded fuel in engines which have original non-hardened valve seats. Treats 120 gallons.

### 12122 "WATER WETTER" ADDITIVE (12 oz. bottle)

Recommended where cooling systems need assistance  
*Offered as a convenience item.*



## Accessories Notes

Opel GT Source offers exterior emblems and exterior parts, plus a selection of various Opel accessories. Our inventory includes specialized tools and selected gasket sealers offered as "convenience items," so you can get everything you need to complete a project delivered at one time (and save the time & expense of making a trip to an auto part store).

### Emblem Identification and Handling

You can consult our illustrated guides to identify correct GT emblem types and locations. When removing or re-installing emblems, we suggest using a rubber spatula for safety and to avoid any impact upon your surface paint.

### Window Washer Parts

A foot pump located to the left of the pedal assembly activates this circuit of hood-mounted sprayers (accompanied by a momentary sweep of the wipers).

### Key Blank Styles

See the preceding page to determine which key blank 'groove' style you need to order. We recommend purchasing extra key blanks (to avoid expense and delays if an original breaks or goes missing).

### Gasket Sealers and Additives

Use per available tech instructions, and be aware that what will work best may vary based on your applications. Always prep surfaces so that they are clean and dry, and consult cure times (which are listed on packaging or labels).

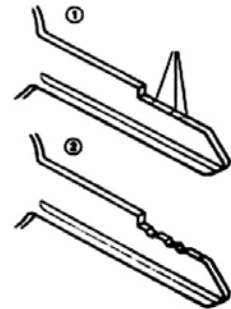

### **“Impression Cut”**

*You can request an old-school locksmithing technique, to have key blanks custom-cut (when you have a lock that didn't come with a key).*

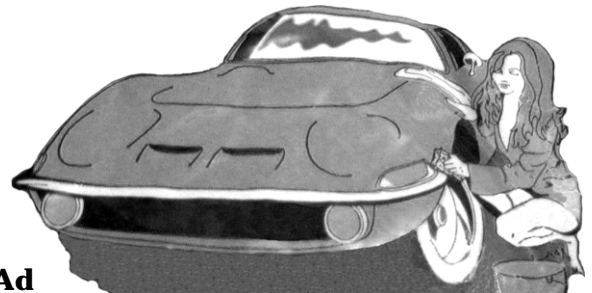

1970's Ad



**12025 Sport Mirror**  
New Reproduction  
*Modern look for classic Opels*



**12017c Gasket Sealer**  
Permatex "High Tack" 4 oz. can  
*Recommended for many applications*



**12013 & 12015 Special Bit Tools**  
8mm fits various bolts  
12mm fits some engine bolts



**Used Accessories also available**  
Contact Opel GT Source with your needs  
[opelgts@opelgtsource.com](mailto:opelgts@opelgtsource.com)



**12001 GT Front Insignia**  
*New Reproduction in Chromed Plastic*



**12094 Emblem Grommets**  
Helps secure exterior emblems  
*Select your version based on model-year*

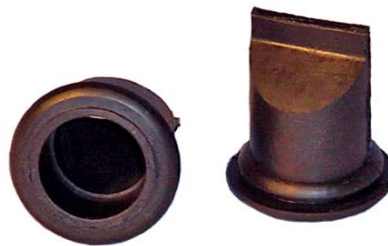

**12010 GT Drain Hose Boots**  
New Rubber Design  
*Helps seal interior from fumes & debris*



**12097 Decal**  
*Door Jamb Tire Inflation sticker*



**12002 "OPEL" Plate**  
*New Reproduction Insignia*



**12004 "G" "T" Rear Insignia**  
New Reproduction for Opel GT  
*Fits early fenders and later model rear.*



**12006 "1900" Rear Emblem**  
Reproduction, new import item  
*Red painted on lat back metal plate*



**12037A GT Key Blanks**  
*Fits many Opel GT ignition/door locks*



**12037B GT Key Blanks**  
*Alternate version, fits most GT gas caps  
and some ignition/door locks*

**13000/Services**



13XXX

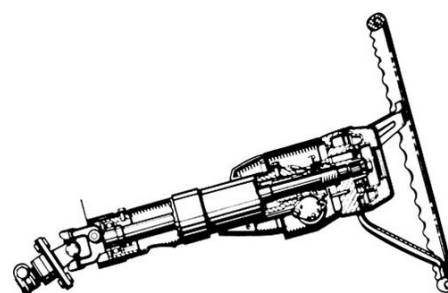
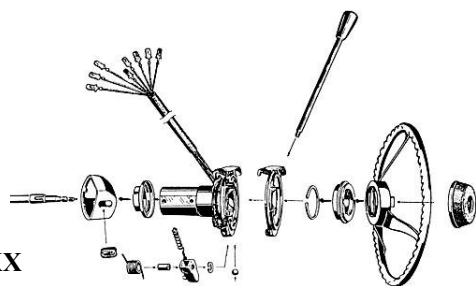

5084

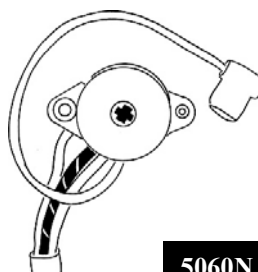
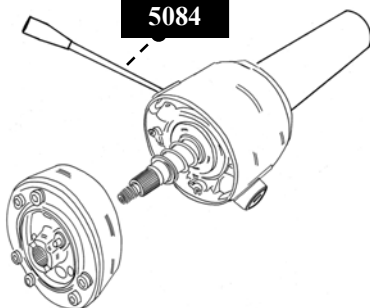

5060N



5064

GT Steering Column Assembly

We supply #5064 turn signal rings and #5060N ignition switches

We also offer rebuilding services, for good core units sent to us.

**Rebuilding Parts & Services**

**13XXX GT STEERING COLUMN REBUILD**

A good option for those without a puller tool, this can include replacement of the #5060N ignition switch and/or replacement of the #5064 turn signal ring and #5084 turn signal stalk. Service requires shipment of a re-buildable Opel GT steering column to us. Labor quoted at shop rate; Additional parts may be installed as required

**1059 OPEL GT STEERING WHEEL**

Reproduction of original walnut-shade GT wheel  
(Offered as an alternative to rebuilding a used wheel)

**1060 OPEL GT STEERING WHEEL**

Reproduction featuring darker mahogany-shade  
(Offered as an alternative to rebuilding a used wheel)

**9044A GT GAS TANK SENDER**

This new aftermarket sender features original-length design for greater accuracy on your dashboard gas gauge. Offered at a new lower price, this item has replaced the #13020 rebuilding service in our inventory.

**13009K GT WINDOW REGULATOR RECABLE KIT**

Replacement cable plus retainer ferrels. Your core unit must have intact, functioning gears.



1059

1060

GT Window Regulators

Left is "early" style

Right is "later" style.

Consider rebuilding yours, with #13009K re-cabling kit.

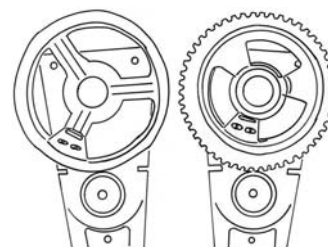

13009K

**OPEL GT SPEEDOMETER SERVICE**

Requires shipment of rebuildable core unit to us. Contact us for additional details.



## Rebuilding Service Notes

At first glance, Opel GT parts like the steering column, window regulator and fuel sender unit may look similar in design and function to other 1960's cars. But a closer look reveals year-to-year internal part design variations and specific disassembly requirements (these hard-to-replace parts). In some cases we advise removing components and shipping them to us (for service when it is required).

### Part Rebuilding & Shop Labor

Opel GT Source offer set prices (when rebuildable-condition used parts are sent to us), and in some cases also provides hourly-rate labor (when parts require additional preparation to be rebuilt).

### Shipment Packaging

When shipping vulnerable, hard-to-replace Opel part cores (such as a gas tank sender unit or a steering column) to us, we suggest packing items within a "double box" for additional protection.

One method is placing the part in a box, adding protective materials (foam peanuts, balls of crumpled newspaper), and placing this within a 2nd box (with an additional 2nd layer of protective materials too) for added security.

### Steering Column details

You can see details in our "part list" and technical notes on our website, regarding internal parts and service procedures of disassembly of the Opel GT steering column.



***Shipment Packaging***  
*Help ensure your core reaches us without damage in transit. Double-box items and use lots of cushion material.*

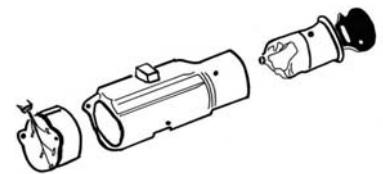

***Lock Hardware***  
*See our tech notes for hardware breakdowns*

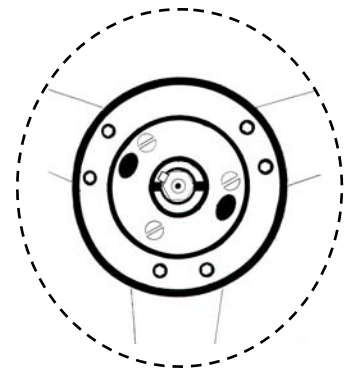

***Steering Column Hub***  
*Removal requires consultation of our tech notes and use of special high-strength oval-shaped bits.*



**14000/Literature**





Create your personal Opel library for convenience and enjoyment

### Opel GT Source Catalogs

#### PC OPEL GT PART LIST/PROJECT GUIDE

"Yellow Cover" OGTS's Opel GT parts & tech guide  
Updated to list entire new part inventory, 80 pages.

#### PL OPEL MANTA/ASCONA PART LIST

"Green Cover" OGTS' Manta/Ascona parts & tech guide  
40 pages

#### OPEL GT DIGITAL CATALOG

A FREE download available online within the "tips" section of the <http://www.opelgtsource.com> website

### Books for Opel Enthusiasts

#### 14025 OPEL GT ULTIMATE PORTFOLIO BOOK

The best introductory book for someone who wants to learn about development and history of the Opel GT. 57 articles, ads, road tests, comparison tests,. Performance specifications and other data, hours of interesting reading. 200 pages (30 in color)

#### 14023 PROJEKT 1484

Many exclusive photographs accompany informative German text. The best book ever on classic Opel GT's.

#### 14024 OPEL MANTA LIMITED EDITION BOOK

The Original Opel Manta Magazine articles and test reports compiled under one cover. Includes Rallye, Luxus, Berlinetta, Broadspeed & May Turbo Manta, TE2800, historic road tests. A must for any Opel Manta enthusiast.

#### 14027 OPEL GT MOTORSPORT BOOK

##### Racing History of Opel GT in Europe

This is a MUST HAVE book for anyone that is into Opel GT racing history! Covering Steinmetz, Conrero, Greder and other Opel GT racers from the 1970's European circuit. Writing in both English and German. Full of rare pictures and data charts, hardcover.

### Opel File

Opel GT Source advises creating a personal Opel file that includes important papers (such as vehicle title, registration, and classic-car type insurance documents) as well as service histories and part purchase invoices, technical flyers, a set of extra keys, and so on, for later reference or use when necessary.



### Gift Certificates

#### GIFT OPEL GT SOURCE GIFT CERTIFICATE

The ideal gift for all Opel GT owners!  
Available in your choice of amount.  
Available in print by mail, or digital version by email.

### Service Manuals & Related

#### 14001 GT ELECTRICAL SECTION COPIES

Individual GT circuit-by-circuit wiring diagrams & overall schematics.

#### 14008 GT OWNERS WORKSHOP MANUAL

The only Opel GT Service Manual still in print

#### 14009 OPEL GT OWNERS MANUAL

Reprint of Opel GT "Glovebox" manual, explains car functions. New. 65 pages, with illustrations.

#### 14019 WEBER CARBURETOR BOOK

Service manual for DGV-series and DGAS downdraft type carbs. Over 180 pgs.

#### 14026 WEBER CARBURETOR TUNING MANUAL

Operating principles, part applications, features DCOE side-draft types. 92 pgs.

# Opel Literature Notes



Because service procedures for Opels can differ dramatically from other cars, every Opel GT owner should own at least one service manual. But because all Opel service manuals contain some inaccuracies (particularly when they miss year-to-year part design changes), Opel GT Source also provides "tech tip" instructions with many of our parts, to inform clients of critical Opel-specific mechanical procedures

## Service Manuals

Feedback from Opel owners has indicated that the Chilton, Clymer, Drake, and the 1969-1970 Opel factory guides can be unreliable as they leave out some necessary information and also advocate some impractical service techniques.

*Our experience shows that the "best" overall service guides for the Opel GT, would be a combination of the #14008 Owner's Workshop Manual and a 1971, 1972 or 1973 Opel Factory Service Manual.*

## Recommendations

We also recommend obtaining updated technical information from some alternate and reputable sources, such as "tech tips" Opel GT Source offers online (and provides with many parts).

*We advise taking caution accessing information found elsewhere, such as on the Internet, as it can be (and often is) inaccurate—particularly when parts or services are being marketed for sale for classic Opels.*

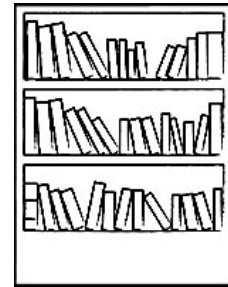

***Your "Opel Library"***  
*Consider recommendations here regarding part catalogs, service manuals, and books on Opel GT history.*



***Opel GT Source "Tech Tips"***  
*See free tech downloads (in the "tips" section of our website) and other information (supplied with many parts that we sell)*

## Recommended

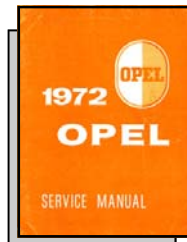
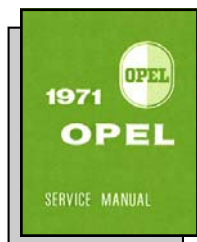

## Others

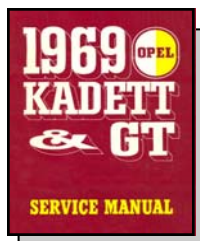



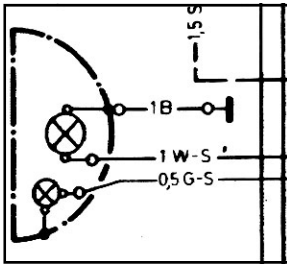

**14001 GT Wiring Schematics**  
Copies of GT circuit diagrams  
*Offered as a convenience item*

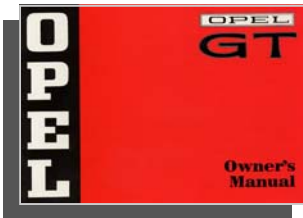

**14009 Opel GT Owners Manual**  
*Reprint of original glovebox manual*

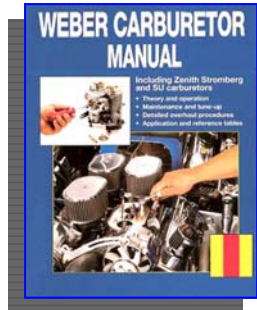

**14019 Weber Carb Manual**  
*Service Guide for DGV, DGAS series*



**Additional Documents**  
*Contact Opel GT Source with your needs*  
[opelgts@opelgtsource.com](mailto:opelgts@opelgtsource.com)



**GIFT Gift Certificate**  
Available in your choice of amount  
*Print or Digital versions offered*

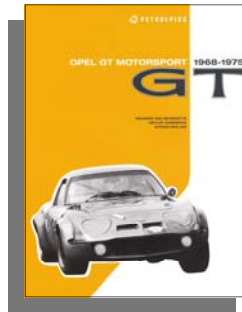

**14027 Opel GT Motorsport Book**  
*Excellent book on GT racing*

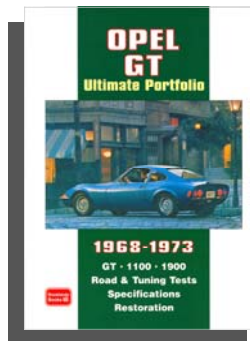

**14025 Opel GT Ultimate Portfolio**  
*Great collection of road tests and historic Opel GT magazine articles*

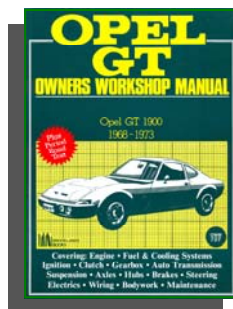

**14008 GT Workshop Manual**  
*Only manual available new in print*

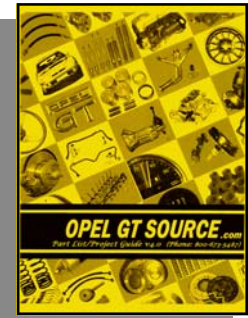

**PC Opel GT "Part List"**  
*"Yellow Cover" parts & tech guide*  
*Recommended for all Opel GT owners*

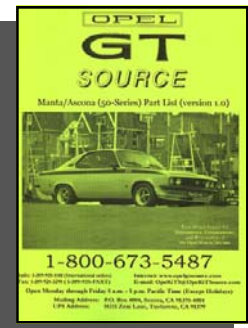

**PL Opel Manta/Ascona "Part List"**  
*"Green Cover" parts & tech guide*  
*Best for Manta/Ascona/1900 Series*



**Opel GT Digital Catalog v2.1**  
Latest Edition, Adobe Acrobat format  
*FREE download from our website*



**Opel GT Source Tech Notes**  
*Available with many parts we sell*

# Document Disclaimers



## Document Disclaimers/Ordering Policies

Where they appear in this document, the names "Opel", "Opel GT", etc. are used only to describe the vehicles which the parts are listed to fit, and in no way indicates or implies any connection with Adam Opel A.G., General Motors, or any dealership (or any of their corporate heirs or assigns), except as a source of parts for our business.

Illustrations provided in this document are for reference only, as individual parts are referenced by text descriptions. Where listed, technical suggestions are provided as advisories only, based upon our experience with Opels (yours may differ). We are not responsible for errors (typographical or otherwise), omissions, misunderstandings, or for any unintended or alternate use of this document. All rights are reserved on all original images and text in this document.

(We advise all Opel owners to research their individual part needs, to consult a professional mechanic regarding evaluation or service of their vehicle, and to use proper and sufficient safety procedures when performing any repair).

We also suggest readers contact us to complete any and all individual transactions, as part availability and part prices are subject to change at any time, without notice.

Opel GT Source guarantees your parts to be free from defects in materials and workmanship, only to the extent of its product value. We will be liable for their replacement or refund at our option. Claims for shortage or error in shipment must be made within three (3) days of receipt of shipment. We do not guarantee parts used in competition, off-road and/or racing applications or those damaged due to misuse, improper installation, or application.

We accept no liability for down-time or loss of transportation due to parts defects or failures, nor to any additional labor required to remedy this situation. In no event shall our liability exceed the cost of the goods. All parts are warranted for 30 days from date of purchase (except electrical parts and special orders or unless otherwise specified). Claims are started by calling us for a parts return authorization.

Properly pack item in original box, insure and ship your return by UPS Ground or US Priority Mail prepaid so that it arrives here in re-saleable condition and include a copy of your invoice for proof of date of purchase. We will refund your cost of shipping if your part is determined to be defective. All sales are considered final. Returns after 30 days are at our discretion and for store credit only.

As some parts listed may not meet emissions standards in all areas, we also advise clients to consult local experts for any applicable registration or vehicle operation requirements.

S	M	T	W	T	F	S
		1	2	3	4	5
6	7	8	9	10	11	12
13	14	15	16	17	18	19
20	21	22	23	24	25	26
27	28	29	30			

All Rights Reserved  
©Opel GT Source 4/2017



Better Parts + Better Service  
= Better Performance

